



# Radiation Hardened, High Performance Industry Standard Single-Ended Current Mode PWM Controller

## ISL78840ASRH, ISL78841ASRH, ISL78843ASRH, ISL78845ASRH

The ISL7884xASRH is a high performance, radiation hardened drop-in replacement for the popular 28C4x and 18C4x PWM controllers suitable for a wide range of power conversion applications including boost, flyback, and isolated output configurations. Its fast signal propagation and output switching characteristics make this an ideal product for existing and new designs.

Features include up to 13.2V operation, low operating current, 90µA typ start-up current, adjustable operating frequency to 1MHz, and high peak current drive capability with 50ns rise and fall times.

PART NUMBER	RISING UVLO	MAX. DUTY CYCLE
ISL78840ASRH	7.0	100%
ISL78841ASRH	7.0	50%
ISL78843ASRH	8.4V	100%
ISL78845ASRH	8.4V	50%

Specifications for Rad Hard QML devices are controlled by the Defense Supply Center in Columbus (DSCC). The SMD numbers listed in the ordering information must be used when ordering.

Detailed Electrical Specifications for the ISL788xASRH are contained in SMD 5962-07249. A "hot-link" is provided on our website for downloading.

### Features

- Electrically Screened to DSCC SMD # 5962-07249
- QML Qualified Per MIL-PRF-38535 Requirements
- 1A MOSFET Gate Driver
- 90µA Typ Start-up Current, 125µA Max
- 35ns Propagation Delay Current Sense to Output
- Fast Transient Response with Peak Current Mode Control
- 9V to 13.2V Operation
- Adjustable Switching Frequency to 1MHz
- 50ns Rise and Fall Times with 1nF Output Load
- Trimmed Timing Capacitor Discharge Current for Accurate Deadtime/Maximum Duty Cycle Control
- 1.5MHz Bandwidth Error Amplifier
- Tight Tolerance Voltage Reference Over Line, Load and Temperature
- ±3% Current Limit Threshold
- Pb-Free Available (RoHS Compliant)

### Applications

- Current Mode Switching Power Supplies
- Isolated Buck and Flyback Regulators
- Boost Regulators
- Direction and Speed Control in Motors
- Control of High Current FET Drivers

ISL78840ASRH, ISL78841ASRH, ISL78843ASRH, ISL78845ASRH

## Pin Configuration

ISL78840ASRH, ISL78841ASRH,  
ISL78843ASRH, ISL78845ASRH  
(8 LD FLATPACK)  
TOP VIEW

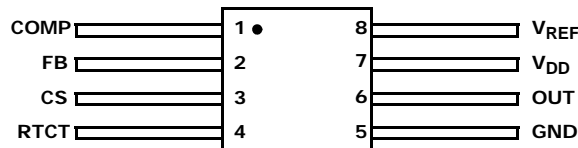

## Ordering Information

ORDERING NUMBER	PART NUMBER	TEMP. RANGE (°C)	PACKAGE (Pb-Free)
ISL78840ASRHF/PROTO	ISL78840ASRHF/PROTO (Notes 1, 2)	-55 to +125	8 Ld Flatpack
5962R0724901QXC	ISL78840ASRHQF (Notes 1, 2)	-55 to +125	8 Ld Flatpack
5962R0724901VXC	ISL78840ASRHVF (Notes 1, 2)	-55 to +125	8 Ld Flatpack
ISL78840ASRHVX/SAMPLE	ISL78840ASRHVX/SAMPLE	-55 to +125	Die
ISL78841ASRHF/PROTO	ISL78841ASRHF/PROTO (Notes 1, 2)	-55 to +125	8 Ld Flatpack
5962R0724902QXC	ISL78841ASRHQF (Notes 1, 2)	-55 to +125	8 Ld Flatpack
5962R0724902VXC	ISL78841ASRHVF (Notes 1, 2)	-55 to +125	8 Ld Flatpack
ISL78841ASRHVX/SAMPLE	ISL78841ASRHVX/SAMPLE	-55 to +125	Die
ISL78843ASRHF/PROTO	ISL78843ASRHF/PROTO (Notes 1, 2)	-55 to +125	8 Ld Flatpack
5962R0724903QXC	ISL78843ASRHQF (Notes 1, 2)	-55 to +125	8 Ld Flatpack
5962R0724903VXC	ISL78843ASRHVF (Notes 1, 2)	-55 to +125	8 Ld Flatpack
ISL78843ASRHVX/SAMPLE	ISL78843ASRHVX/SAMPLE	-55 to +125	Die
ISL78845ASRHF/PROTO	ISL78845ASRHF/PROTO (Notes 1, 2)	-55 to +125	8 Ld Flatpack
5962R0724904QXC	ISL78845ASRHQF (Notes 1, 2)	-55 to +125	8 Ld Flatpack
5962R07 24904VXC	ISL78845ASRHVF (Notes 1, 2)	-55 to +125	8 Ld Flatpack
ISL78845ASRHVX/SAMPLE	ISL78845ASRHVX/SAMPLE	-55 to +125	Die

NOTES:

1. These Intersil Pb-free Hermetic packaged products employ 100% Au plate - e4 termination finish, which is RoHS compliant and compatible with both SnPb and Pb-free soldering operations.
2. For Moisture Sensitivity Level (MSL), please see device information page for [ISL78840ASRH](#), [ISL78841ASRH](#), [ISL78843ASRH](#), [ISL78845ASRH](#). For more information on MSL please see techbrief [TB363](#).

# Functional Block Diagram

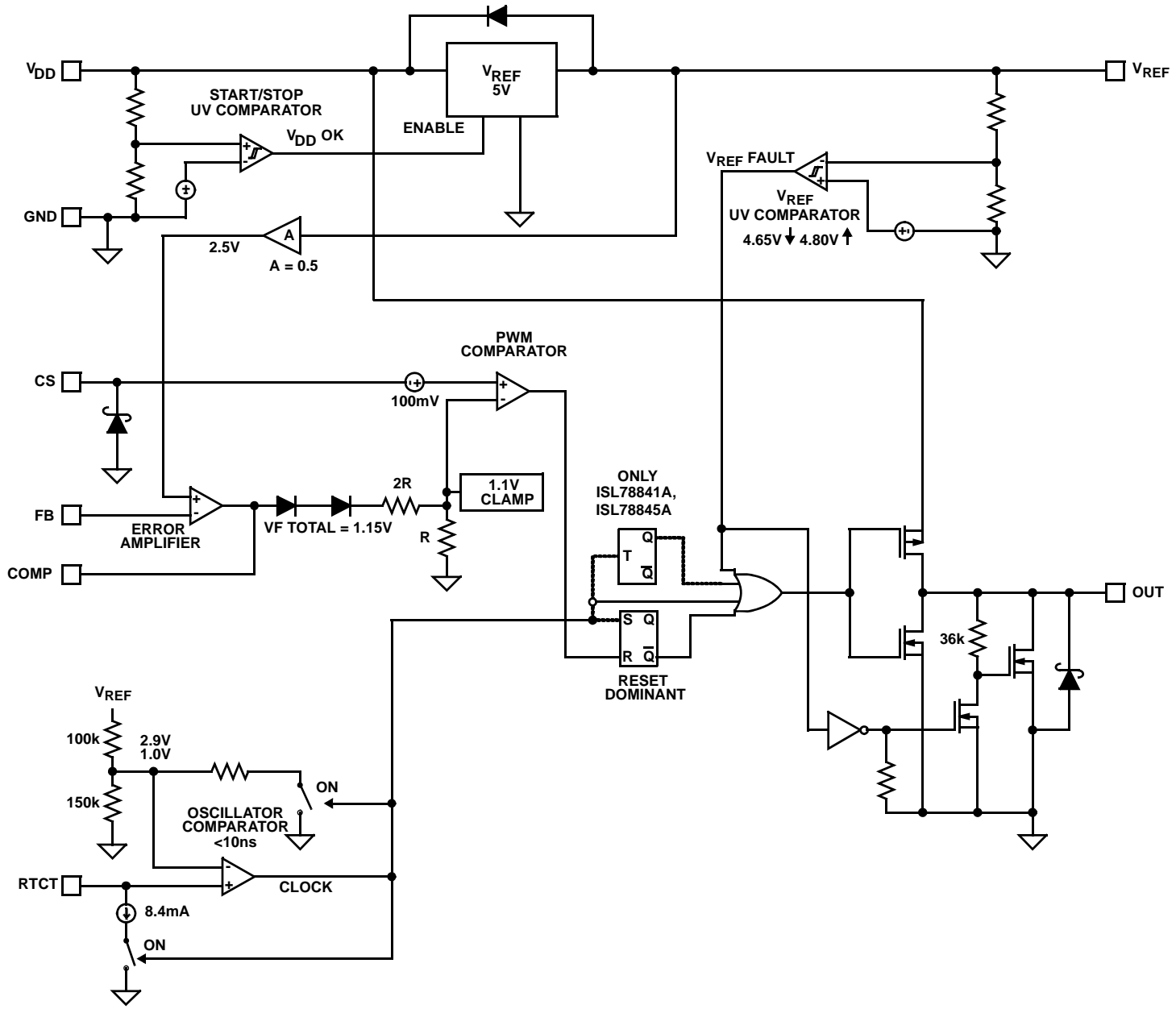

ISL78840ASRH, ISL78841ASRH, ISL78843ASRH, ISL78845ASRH

# Typical Application - 48V Input Dual Output Flyback

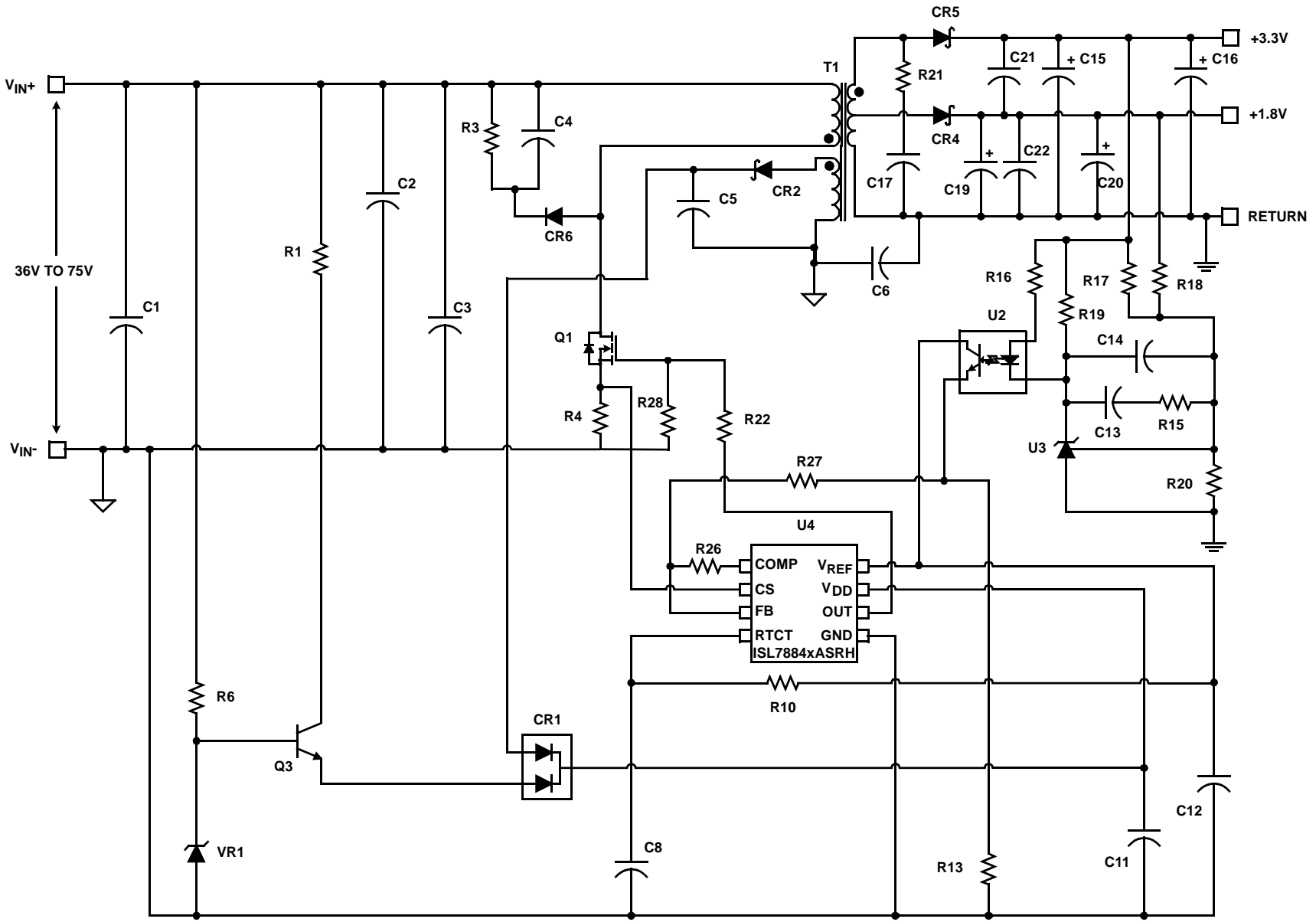

ISL78840ASRH, ISL78841ASRH, ISL78843ASRH, ISL78845ASRH

### Typical Application - Boost Converter

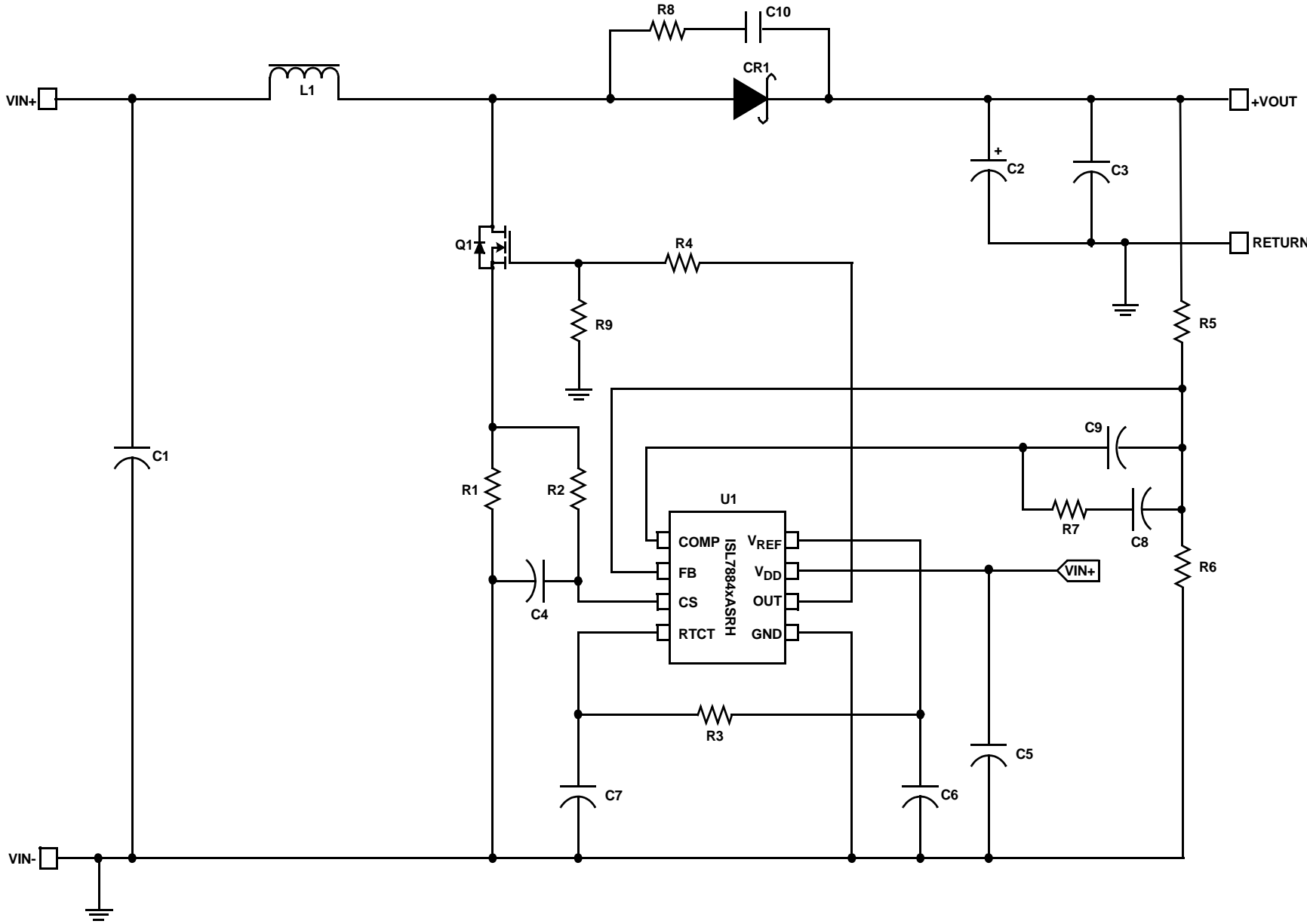

## Typical Performance Curves

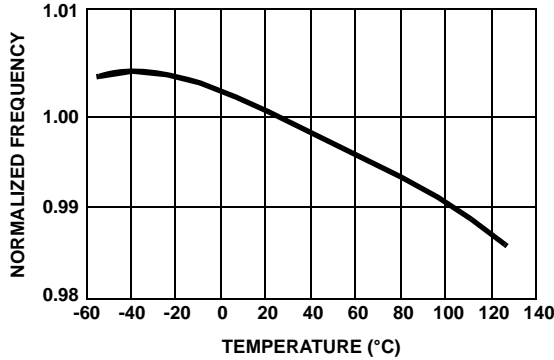

FIGURE 1. FREQUENCY vs TEMPERATURE

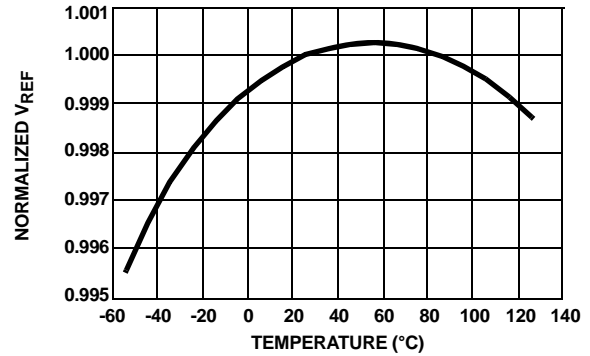

FIGURE 2. REFERENCE VOLTAGE vs TEMPERATURE

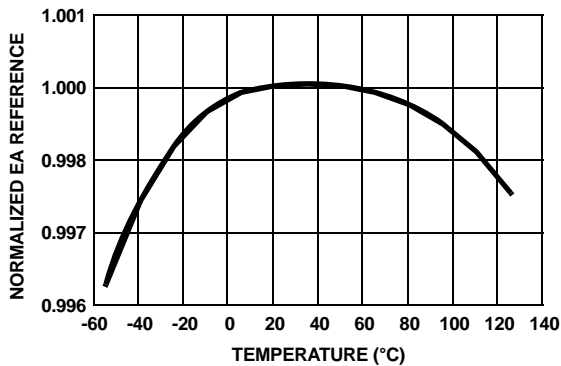

FIGURE 3. EA REFERENCE vs TEMPERATURE

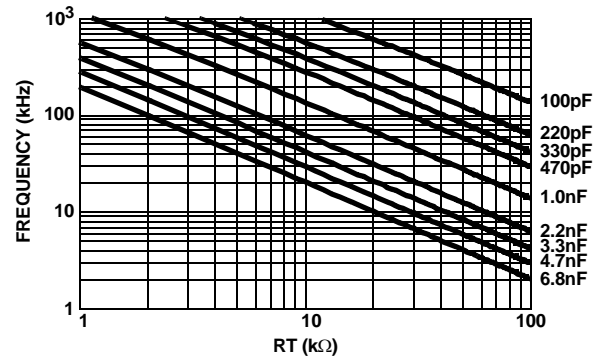

FIGURE 4. RESISTANCE FOR CT CAPACITOR VALUES GIVEN

## Pin Descriptions

**RTCT** - This is the oscillator timing control pin. The operational frequency and maximum duty cycle are set by connecting a resistor,  $R_T$ , between  $V_{REF}$  and this pin and a timing capacitor,  $C_T$ , from this pin to GND. The oscillator produces a sawtooth waveform with a programmable frequency range up to 2.0MHz. The charge time,  $t_C$ , the discharge time,  $t_D$ , the switching frequency,  $f$ , and the maximum duty cycle,  $D_{MAX}$ , can be approximated from the Equations 1 through 4:

$$t_C \approx 0.533 \cdot R_T \cdot C_T \quad (\text{EQ. 1})$$

$$t_D \approx -R_T \cdot C_T \cdot \ln\left(\frac{0.008 \cdot R_T - 3.83}{0.008 \cdot R_T - 1.71}\right) \quad (\text{EQ. 2})$$

$$f = 1/(t_C + t_D) \quad (\text{EQ. 3})$$

$$D = t_C \cdot f \quad (\text{EQ. 4})$$

The formulae have increased error at higher frequencies due to propagation delays. Figure 4 may be used as a guideline in selecting the capacitor and resistor values required for a given switching frequency for the ISL78841, ISL78845ASRH. The value for the ISL78840, ISL78843ASRH will be twice that shown in Figure 4.

**COMP** - COMP is the output of the error amplifier and the input of the PWM comparator. The control loop frequency compensation network is connected between the COMP and FB pins.

**FB** - The output voltage feedback is connected to the inverting input of the error amplifier through this pin. The non-inverting input of the error amplifier is internally tied to a reference voltage.

**CS** - This is the current sense input to the PWM comparator. The range of the input signal is nominally 0V to 1.0V and has an internal offset of 100mV.

**GND** - GND is the power and small signal reference ground for all functions.

**OUT** - This is the drive output to the power switching device. It is a high current output capable of driving the gate of a power MOSFET with peak currents of 1.0A. This GATE output is actively held low when  $V_{DD}$  is below the UVLO threshold.

**VDD** -  $V_{DD}$  is the power connection for the device. The total supply current will depend on the load applied to OUT. Total  $I_{DD}$  current is the sum of the operating current and the average output current. Knowing the operating frequency,  $f$ , and the MOSFET gate charge,  $Q_g$ ,

the average output current can be calculated from Equation 5:

$$I_{OUT} = Qg \times f \quad (\text{EQ. 5})$$

To optimize noise immunity, bypass  $V_{DD}$  to GND with a ceramic capacitor as close to the  $V_{DD}$  and GND pins as possible.

**$V_{REF}$**  - The 5.00V reference voltage output. +1.0/-1.5% tolerance over line, load and operating temperature. The recommended bypass to GND cap is in the range 0.1 $\mu$ F to 0.22 $\mu$ F. A typical value of 0.15 $\mu$ F can be used.

## Functional Description

### Features

The ISL7884xASRH current mode PWM makes an ideal choice for low-cost flyback and forward topology applications. With its greatly improved performance over industry standard parts, it is the obvious choice for new designs or existing designs which require updating.

### Oscillator

The ISL7884xASRH has a sawtooth oscillator with a programmable frequency range to 2MHz, which can be programmed with a resistor from  $V_{REF}$  and a capacitor to GND on the RTCT pin. (Please refer to Figure 4 for the resistor and capacitance required for a given frequency).

### Soft-Start Operation

Soft-start must be implemented externally. One method, illustrated below, clamps the voltage on COMP.

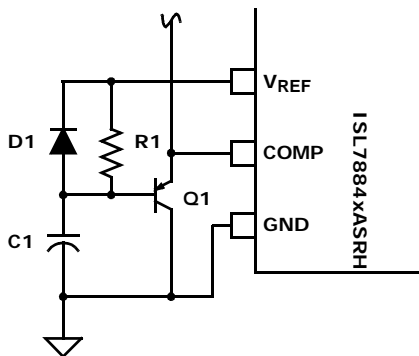

FIGURE 5. SOFT-START

The COMP pin is clamped to the voltage on capacitor  $C_1$  plus a base-emitter junction by transistor  $Q_1$ .  $C_1$  is charged from  $V_{REF}$  through resistor  $R_1$  and the base current of  $Q_1$ . At power-up  $C_1$  is fully discharged, COMP is at  $-0.7V$ , and the duty cycle is zero. As  $C_1$  charges, the voltage on COMP increases, and the duty cycle increases in proportion to the voltage on  $C_1$ . When COMP reaches the steady state operating point, the control loop takes over and soft start is complete.  $C_1$  continues to charge up to  $V_{REF}$  and no longer affects COMP. During power down, diode  $D_1$  quickly discharges  $C_1$  so that the soft start circuit is properly initialized prior to the next power on sequence.

### Gate Drive

The ISL7884xASRH is capable of sourcing and sinking 1A peak current. To limit the peak current through the IC, an optional external resistor may be placed between the totem-pole output of the IC (OUT pin) and the gate of the MOSFET. This small series resistor also damps any oscillations caused by the resonant tank of the parasitic inductances in the traces of the board and the FET's input capacitance. TID environment of >50krads requires the use of a bleeder resistor of 10k from OUT pin to GND.

### Slope Compensation

For applications where the maximum duty cycle is less than 50%, slope compensation may be used to improve noise immunity, particularly at lighter loads. The amount of slope compensation required for noise immunity is determined empirically, but is generally about 10% of the full scale current feedback signal. For applications where the duty cycle is greater than 50%, slope compensation is required to prevent instability.

Slope compensation may be accomplished by summing an external ramp with the current feedback signal or by subtracting the external ramp from the voltage feedback error signal. Adding the external ramp to the current feedback signal is the more popular method.

From the small signal current-mode model [1] it can be shown that the naturally-sampled modulator gain,  $F_m$ , without slope compensation is calculated in Equation 6:

$$F_m = \frac{1}{S_n T_{sw}} \quad (\text{EQ. 6})$$

where  $S_n$  is the slope of the sawtooth signal and  $t_{sw}$  is the duration of the half-cycle. When an external ramp is added, the modulator gain becomes Equation 7:

$$F_m = \frac{1}{(S_n + S_e)t_{sw}} = \frac{1}{m_c S_n t_{sw}} \quad (\text{EQ. 7})$$

where  $S_e$  is slope of the external ramp and becomes Equation 8:

$$m_c = 1 + \frac{S_e}{S_n} \quad (\text{EQ. 8})$$

The criteria for determining the correct amount of external ramp can be determined by appropriately setting the damping factor of the double-pole located at the switching frequency. The double-pole will be critically damped if the Q-factor is set to 1, over-damped for  $Q < 1$ , and under-damped for  $Q > 1$ . An under-damped condition may result in current loop instability.

$$Q = \frac{1}{\pi(m_c(1-D) - 0.5)} \quad (\text{EQ. 9})$$

where D is the percent of on time during a switching cycle. Setting  $Q = 1$  and solving for  $S_e$  yields Equation 10:

$$S_e = S_n \left( \left( \frac{1}{\pi} + 0.5 \right) \frac{1}{1-D} - 1 \right) \quad (\text{EQ. 10})$$

Since  $S_n$  and  $S_e$  are the on time slopes of the current ramp and the external ramp, respectively, they can be multiplied by  $t_{ON}$  to obtain the voltage change that occurs during  $t_{ON}$ .

$$V_e = V_n \left( \left( \frac{1}{\pi} + 0.5 \right) \frac{1}{1-D} - 1 \right) \quad (\text{EQ. 11})$$

where  $V_n$  is the change in the current feedback signal ( $\Delta I$ ) during the on time and  $V_e$  is the voltage that must be added by the external ramp.

For a flyback converter,  $V_n$  can be solved for in terms of input voltage, current transducer components, and primary inductance, yielding Equation 12:

$$V_e = \frac{D \cdot T_{SW} \cdot V_{IN} \cdot R_{CS}}{L_p} \left( \left( \frac{1}{\pi} + 0.5 \right) \frac{1}{1-D} - 1 \right) \quad V \quad (\text{EQ. 12})$$

where  $R_{CS}$  is the current sense resistor,  $f_{SW}$  is the switching frequency,  $L_p$  is the primary inductance,  $V_{IN}$  is the minimum input voltage, and D is the maximum duty cycle.

The current sense signal at the end of the ON time for CCM operation is Equation 13:

$$V_{CS} = \frac{N_s \cdot R_{CS}}{N_p} \left( I_O + \frac{(1-D) \cdot V_O \cdot f_{sw}}{2L_s} \right) \quad V \quad (\text{EQ. 13})$$

where  $V_{CS}$  is the voltage across the current sense resistor,  $L_s$  is the secondary winding inductance, and  $I_O$  is the output current at current limit. Equation 13 assumes the voltage drop across the output rectifier is negligible.

Since the peak current limit threshold is 1.00V, the total current feedback signal plus the external ramp must sum to this value when the output load is at the current limit threshold as shown in Equation 14.

$$V_e + V_{CS} = 1 \quad (\text{EQ. 14})$$

Substituting Equations 12 and 13 into Equation 14 and solving for  $R_{CS}$  yields Equation 15:

$$R_{CS} = \frac{1}{\frac{D \cdot f_{sw} \cdot V_{IN}}{L_p} \cdot \left( \frac{1}{1-D} - 1 \right) + \frac{N_s}{N_p} \cdot \left( I_O + \frac{(1-D) \cdot V_O \cdot f_{sw}}{2L_s} \right)} \quad (\text{EQ. 15})$$

Adding slope compensation is accomplished in the ISL7884xASRH using an external buffer transistor and the RTCT signal. A typical application sums the buffered

RTCT signal with the current sense feedback and applies the result to the CS pin as shown in Figure 6.

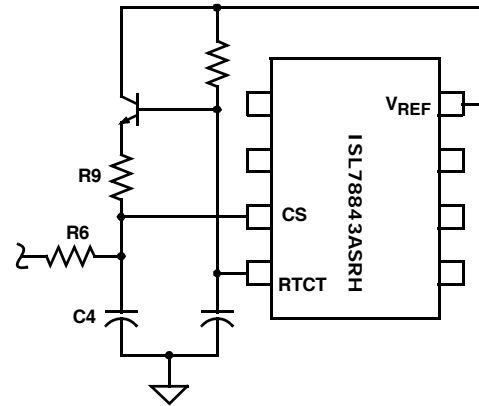

FIGURE 6. SLOPE COMPENSATION

Assuming the designer has selected values for the RC filter ( $R_6$  and  $C_4$ ) placed on the CS pin, the value of  $R_9$  required to add the appropriate external ramp can be found by superposition.

$$V_e = \frac{2.05D \cdot R_6}{R_6 + R_9} \quad V \quad (\text{EQ. 16})$$

The factor of 2.05 in Equation 16 arises from the peak amplitude of the sawtooth waveform on RTCT minus a base-emitter junction drop. That voltage multiplied by the maximum duty cycle is the voltage source for the slope compensation. Rearranging to solve for  $R_9$  yields Equation 17:

$$R_9 = \frac{(2.05D - V_e) \cdot R_6}{V_e} \quad \Omega \quad (\text{EQ. 17})$$

The value of  $R_{CS}$  determined in Equation 15 must be rescaled so that the current sense signal presented at the CS pin is that predicted by Equation 13. The divider created by  $R_6$  and  $R_9$  makes this necessary.

$$R'_{CS} = \frac{R_6 + R_9}{R_9} \cdot R_{CS} \quad (\text{EQ. 18})$$

Example:

$$V_{IN} = 12V$$

$$V_O = 48V$$

$$L_s = 800\mu H$$

$$N_s/N_p = 10$$

$$L_p = 8.0\mu H$$

$$I_O = 200mA$$

$$\text{Switching Frequency, } f_{sw} = 200kHz$$

$$\text{Duty Cycle, } D = 28.6\%$$

$$R_6 = 499\Omega$$

Solve for the current sense resistor,  $R_{CS}$ , using Equation 15.



$$R_{CS} = 295\text{m}\Omega$$

Determine the amount of voltage,  $V_e$ , that must be added to the current feedback signal using Equation 12.

$$V_e = 92.4\text{mV}$$

Using Equation 17, solve for the summing resistor,  $R_9$ , from CT to CS.

$$R_9 = 2.67\text{k}\Omega$$

Determine the new value of  $R_{CS}$  ( $R'_{CS}$ ) using Equation 18.

$$R'_{CS} = 350\text{m}\Omega$$

Additional slope compensation may be considered for design margin. The above discussion determines the minimum external ramp that is required. The buffer transistor used to create the external ramp from RTCT should have a sufficiently high gain ( $>200$ ) so as to minimize the required base current. Whatever base

current is required reduces the charging current into RTCT and will reduce the oscillator frequency.

## Fault Conditions

A Fault condition occurs if  $V_{REF}$  falls below 4.65V. When a Fault is detected OUT is disabled. When  $V_{REF}$  exceeds 4.80V, the Fault condition clears, and OUT is enabled.

## Ground Plane Requirements

Careful layout is essential for satisfactory operation of the device. A good ground plane must be employed. A unique section of the ground plane must be designated for high di/dt currents associated with the output stage.  $V_{DD}$  should be bypassed directly to GND with good high frequency capacitors.

## References

- [1] Ridley, R., "A New Continuous-Time Model for Current Mode Control", IEEE Transactions on Power Electronics, Vol. 6, No. 2, April 1991.

# Die Map

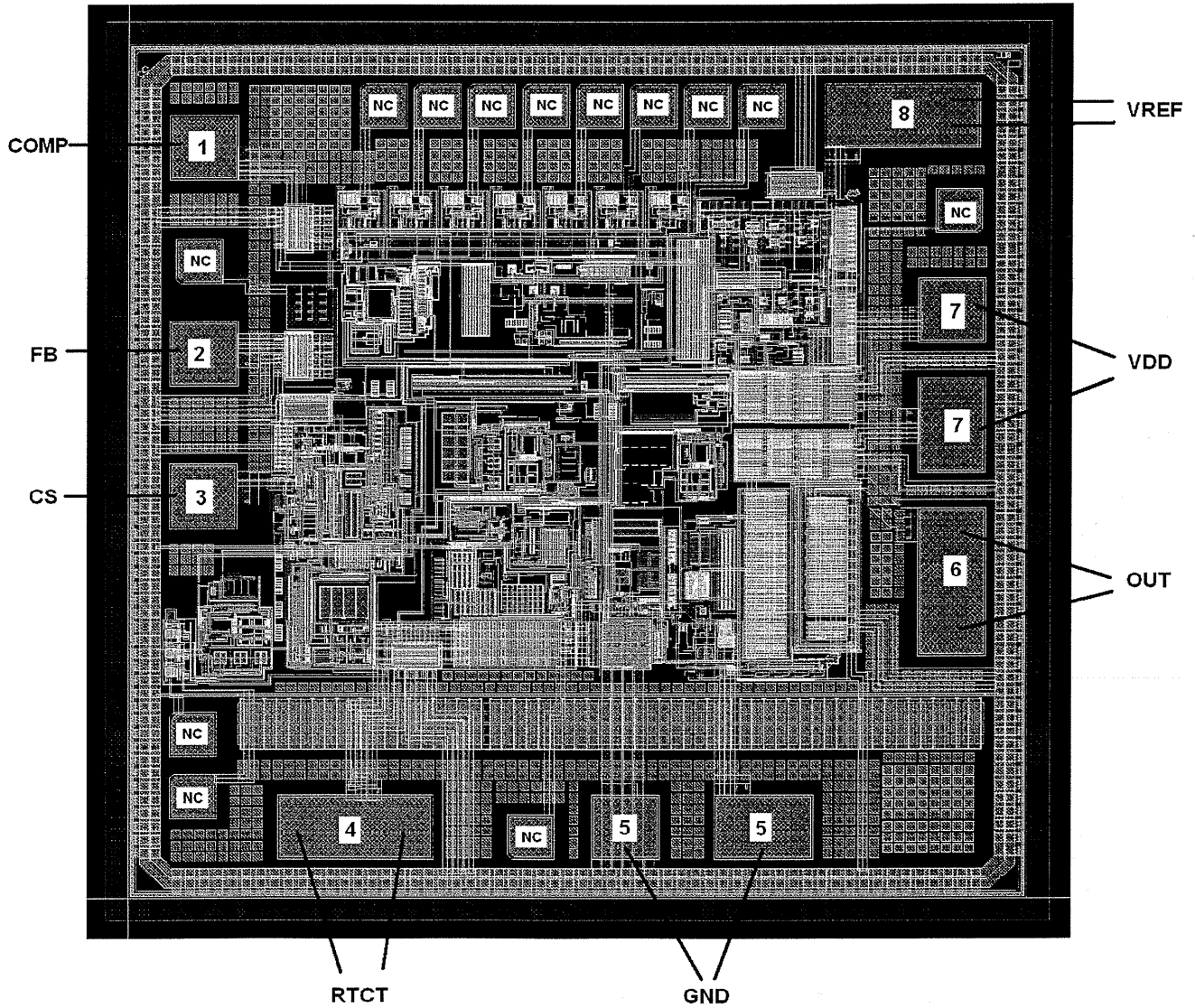

## Revision History

The revision history provided is for informational purposes only and is believed to be accurate, but not warranted. Please go to web to make sure you have the latest Rev.

DATE	REVISION	CHANGE
12/21/09	FN6991.0	Initial Release

---

## Products

Intersil Corporation is a leader in the design and manufacture of high-performance analog semiconductors. The Company's products address some of the industry's fastest growing markets, such as, flat panel displays, cell phones, handheld products, and notebooks. Intersil's product families address power management and analog signal processing functions. Go to [www.intersil.com/products](http://www.intersil.com/products) for a complete list of Intersil product families.

\*For a complete listing of Applications, Related Documentation and Related Parts, please see the respective device information page on intersil.com: [ISL78840ASRH](http://www.intersil.com/products), [ISL78841ASRH](http://www.intersil.com/products), [ISL78843ASRH](http://www.intersil.com/products), [ISL78845ASRH](http://www.intersil.com/products)

To report errors or suggestions for this datasheet, please go to [www.intersil.com/askourstaff](http://www.intersil.com/askourstaff)

FITs are available from our website at <http://rel.intersil.com/reports/search.php>

For additional products, see [www.intersil.com/product\\_tree](http://www.intersil.com/product_tree)

Intersil products are manufactured, assembled and tested utilizing ISO9000 quality systems as noted in the quality certifications found at [www.intersil.com/design/quality](http://www.intersil.com/design/quality)

*Intersil products are sold by description only. Intersil Corporation reserves the right to make changes in circuit design, software and/or specifications at any time without notice. Accordingly, the reader is cautioned to verify that data sheets are current before placing orders. Information furnished by Intersil is believed to be accurate and reliable. However, no responsibility is assumed by Intersil or its subsidiaries for its use; nor for any infringements of patents or other rights of third parties which may result from its use. No license is granted by implication or otherwise under any patent or patent rights of Intersil or its subsidiaries.*

For information regarding Intersil Corporation and its products, see [www.intersil.com](http://www.intersil.com)