

iC-HE

TRIPLE DIFFERENTIAL LINE DRIVER

FEATURES

- ◆ Complementary short-circuit-proof push-pull driver stages for RS422 and 24 V applications up to 2 MHz
- ◆ SO14N package pin-compatible to ET9600
- ◆ Integrated line adaptation for high signal quality at 24 V
- ◆ Moderate slew rate reduces EMI
- ◆ High driving capability of typically 200 mA at 24 V
- ◆ Output saturation of just 0.3 V at 40 mA
- ◆ Tristate function with excessive temperature
- ◆ TTL-/CMOS-compatible Schmitt trigger inputs, voltage-proof to 40 V
- ◆ 4.5 to 35 V single supply operation with low static power dissipation
- ◆ Operating temperature from -25 to 125 °C (-40 °C is optional)
- ◆ 50 mA LED driver with ISET input for current control

APPLICATIONS

- ◆ Line drivers for 24 V control engineering
- ◆ Linear scales and encoders
- ◆ Sensor systems

PACKAGES

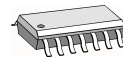

SO14N

BLOCK DIAGRAM

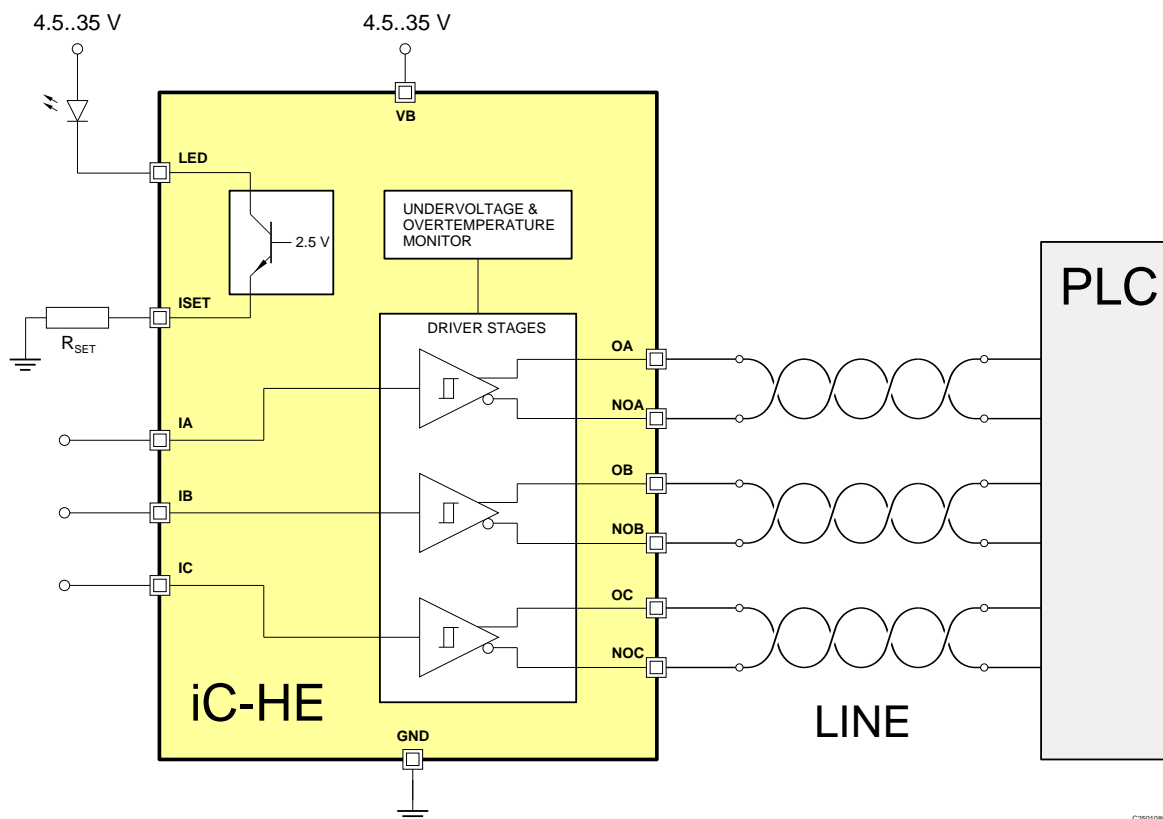

C2501080-1

iC-HE

TRIPLE DIFFERENTIAL LINE DRIVER

DESCRIPTION

The iC-HE is a three channel line driver with complementary outputs optimized for line impedances in the range of 75 Ω .

The push-pull output stages can deliver at least 200 mA from 24 V supply and are short-circuit-proof and current-limited, shutting down with excessive temperature or undervoltage condition.

All inputs are compatible with CMOS and TTL levels.

The emitter and collector outputs of an on-chip NPN transistor is available for driving an external light emitting diode. The base of the transistor is connected to an internal reference voltage of 2.5 V. Collector current at pin LED can be controlled by the value of the resistor connected between ISET and ground.

The device is protected against ESD.

PACKAGES

PIN CONFIGURATION SO14N

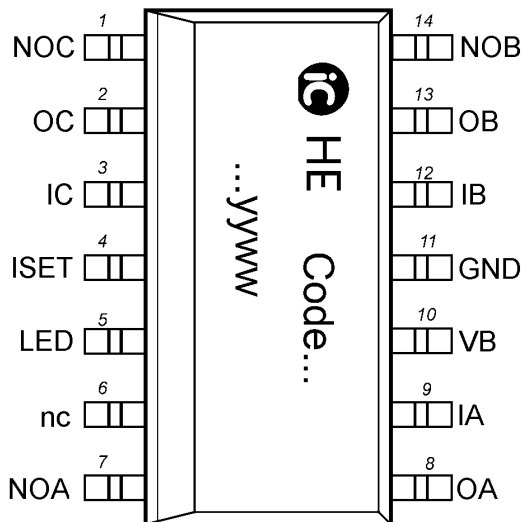

PIN FUNCTIONS

No. Name Function

1	NOC	Inverted Output Driver C
2	OC	Output Driver C
3	IC	Input Driver C
4	ISET	LED Current Setting
5	LED	LED Current Output
6	n.c.	
7	NOA	Inverted Output Driver A
8	OA	Output Driver A
9	IA	Input Driver A
10	VB	Supply Voltage
11	GND	Ground
12	IB	Input Driver B
13	OB	Output Driver B
14	NOB	Inverted Output Driver B

iC-HE

TRIPLE DIFFERENTIAL LINE DRIVER



Rev A1, Page 3/6

ABSOLUTE MAXIMUM RATINGS

Beyond these values damage may occur; device operation is not guaranteed. Absolute Maximum Ratings are no Operating Conditions. Integrated circuits with system interfaces, e.g. via cable accessible pins (I/O pins, line drivers) are per principle endangered by injected interferences, which may compromise the function or durability. The robustness of the devices has to be verified by the user during system development with regards to applying standards and ensured where necessary by additional protective circuitry. By the manufacturer suggested protective circuitry is for information only and given without responsibility and has to be verified within the actual system with respect to actual interferences.

Item No.	Symbol	Parameter	Conditions	Min.		Max.	Unit
G001	VB	Supply Voltage		0	40		V
G002	Vin()	Voltage at Inputs IA, IB, IC		0	VB		V
G003	V()	Voltage at Outputs OA..OC, NOA..NOC		0	VB		V
G004	I()	Current in Outputs OA..OC, NOA..NOC		-500	500		mA
G005	V(LED)	Voltage at LED		0	40		V
G006	I(LED)	Current in LED		-300	300		mA
G007	V(ISET)	Voltage at ISET		0	6		V
G008	I(ISET)	Current in ISET		-300	15		mA
G009	Vd()	ESD Susceptibility	HBM, 100 pF discharged through 1.5 kΩ			2	kV
G010	Tj	Junction Temperature		-40	150		°C
G011	Ts	Storage Temperature		-40	150		°C

THERMAL DATA

Item No.	Symbol	Parameter	Conditions	Min.	Typ.	Max.	Unit
T01	Ta	Operating Ambient Temperature (extended range to -40°C on request)		-25		125	°C
T02	Rthja	Thermal Resistance SO14N	surface mounted, no special heat sink		160		K/W

All voltages are referenced to ground unless otherwise stated.

All currents flowing into the device pins are positive; all currents flowing out of the device pins are negative.

iC-HE

TRIPLE DIFFERENTIAL LINE DRIVER



Rev A1, Page 4/6

ELECTRICAL CHARACTERISTICS

Operating Conditions: $V_B = 4.5...35\text{ V}$, $T_j = -40...125\text{ }^\circ\text{C}$, unless otherwise noted

Item No.	Symbol	Parameter	Conditions				Unit
				Min.	Typ.	Max.	
Total Device							
001	V_B	Permissible Supply Voltage		4.5		35	V
002	$V(\text{LED})$	Permissible Voltage at LED	no clamp diode to V_B	4.5		35	V
003	$I(V_B)$	Supply Current in VCC	no loads on outputs, ISET open		2.6	4	mA
004	$V_c(\text{lo})$	Clamp Voltage low at Ix inputs	$I() = -1\text{ mA}$	-1.2		-0.4	V
005	$V_c(\text{hi})$	Clamp Voltage high at Ix inputs	$I() = 1\text{ mA}$	$V_B + 0.4$		$V_B + 1.2$	V
006	$V_c(\text{lo})$	Clamp Voltage lo at OA, OB, OC, NOA, NOB, NOC	$V_B = 0\text{ V}$, $I() = -10\text{ mA}$	-1.2		-0.4	V
007	$V_c(\text{hi})$	Clamp Voltage hi at OA, OB, OC, NOA, NOB, NOC	$V_B = 0\text{ V}$, $I() = 10\text{ mA}$	$V_B + 0.4$		$V_B + 1.2$	V
008	$V_c(\text{LED})\text{lo}$	Clamp Voltage low at LED	$I() = -10\text{ mA}$	-1.2		-0.4	V
009	$V_c(\text{LED})\text{hi}$	Clamp Voltage high at LED	$I() = 10\text{ mA}$	41		58	V
010	$V_c(\text{ISET})\text{lo}$	Clamp Voltage low at ISET	$V_B = 0\text{ V}$, $I() = -10\text{ mA}$	-1.2		-0.4	V
011	$V_c(\text{ISET})\text{hi}$	Clamp Voltage high at ISET	$V_B = 0\text{ V}$	0.8		2.4	V
Driver Outputs Ox, NOx (x = A...C)							
101	$V_s(\text{lo})$	Saturation voltage low	$I(A) = 40\text{ mA}$		0.2	0.5	V
102	$V_s(\text{hi})$	Saturation voltage high	$I(A) = -40\text{ mA}$		0.3	0.7	V
103	$I_{\text{out}}(\text{hi})$	Output current lo	$V_B = 30\text{ V}$, $V(\text{Ox}, \text{NOx}) = 3\text{ V}$	40	60	90	mA
104	$I_{\text{out}}(\text{hi})$	Output current hi	$V_B = 30\text{ V}$, $V(\text{Ox}, \text{NOx}) = V_B - 3\text{ V}$	-90	-60	-40	mA
105	$I_{\text{sc}}(\text{lo})$	Short-Circuit Current lo	$V_B = 30\text{ V}$, $V(\text{Ox}, \text{NOx}) = V_B$		200	500	mA
106	$I_{\text{sc}}(\text{hi})$	Short-Circuit Current hi	$V(\text{Ox}, \text{NOx}) = 0\text{ V}$	-500	-200		mA
107	$R_{\text{out}}()$	Output Resistance	$V_B = 10...30\text{ V}$, $V(\text{Ox}) = 0.5 * V_B$	50	75	110	Ω
108	$SR(\text{lo}, \text{hi})$	Slew-Rate lo, hi	$V_B = 24\text{ V}$, $CL = 100\text{ pF}$		400		V/ μs
109	$tp(\text{lo}, \text{hi})$	Delay Time lo,hi	not tested, guaranteed by design		75	200	ns
110	$dtp()$	Delay Time Difference	not tested, guaranteed by design	-35		35	ns
111	$I_{\text{lk}}()$	Output Leakage Current	at overtemperature shutdown	-100		100	μA
Driver Inputs Ix (x=A...C)							
201	$V_t(\text{lo})$	Threshold Voltage lo		0.8			V
202	$V_t(\text{hi})$	Threshold Voltage hi				2.4	V
203	$V_t(\text{hys})$	Input Hysteresis		0.1	0.2		V
204	$I()$	Input Leakage Current in Ix	$0\text{ V} < V(I_x) < 5\text{ V}$	-5		5	μA
Undervoltage Detection							
501	V_{off}	Undervoltage Threshold lo		2	3.4		V
502	V_{on}	Undervoltage Threshold hi			3.5	4.1	V
503	V_{hys}	Hysteresis		35	100		mV
504	$tp(\text{shut})$	Reset Delay Time			20		μs
Thermal Shutdown							
601	T_{off}	Shutdown Temperature		130	150	170	$^\circ\text{C}$
602	ΔT_{off}	Hysteresis			8		$^\circ\text{C}$
LED driver							
701	$TC(\text{ISET})$	Temp.- Koeffizient at ISET	$I(\text{ISET}) = 10\text{ mA}$		2.0		mV/ $^\circ\text{K}$
702	$V(\text{ISET})$	Voltage at ISET	$T_j = 27\text{ }^\circ\text{C}$; $I(\text{ISET}) = 1\text{ mA}$	1.7	1.93	2.2	V
703	$V(\text{ISET})$	Voltage at LED	$T_j = 27\text{ }^\circ\text{C}$; $I(\text{ISET}) = 10\text{ mA}$	1.5	1.82	2.1	V
704	$V(\text{ISET})$	Voltage at ISET	$T_j = 27\text{ }^\circ\text{C}$; $I(\text{ISET}) = 50\text{ mA}$	1.3	1.64	2	V
705	CR	Current Ratio $I(\text{LED})/I(\text{ISET})$	$I(\text{ISET}) = 1 \dots 50\text{ mA}$	0.97		1	
706	$I_{\text{sc}}(\text{LED})$	Short-Circuit Current in LED	$V(\text{ISET}) = 0\text{ V}$	65	125	250	mA
707	$V_s(\text{LED})$	Saturation Voltage NPN	$V_s(\text{LED}) = V(\text{LED}) - V(\text{ISET})$; $I(\text{LED}) = 1\text{ mA}$		0.15	0.4	V
708	$V_s(\text{LED})$	Saturation Voltage NPN	$V_s(\text{LED}) = V(\text{LED}) - V(\text{ISET})$; $I(\text{LED}) = 50\text{ mA}$		0.55	1.2	V
709	$I_{\text{lk}}(\text{LED})$	Leakage Current in LED	ISET open, $V(\text{LED}) = 35\text{ V}$			100	μA

ELECTRICAL CHARACTERISTICS

Operating Conditions: $V_B = 4.5...35\text{ V}$, $T_j = -40...125\text{ }^\circ\text{C}$, unless otherwise noted

Item No.	Symbol	Parameter	Conditions	Min.	Typ.	Max.	Unit
710	I _{lk(LED)}	Leakage Current in LED	over temperature condition, $V(\text{LED}) = 35\text{ V}$			200	μA

ELECTRICAL CHARACTERISTICS: Diagrams

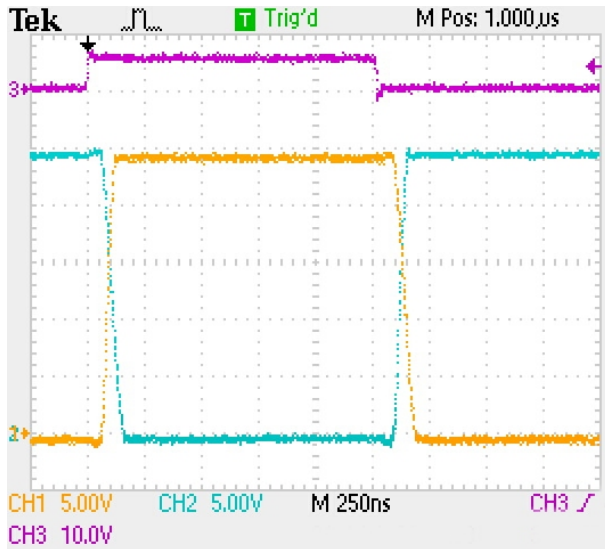

Figure 1: Example of moderate slew rate with unloading Ox and NOx outputs ($V_B = 24\text{ V}$)

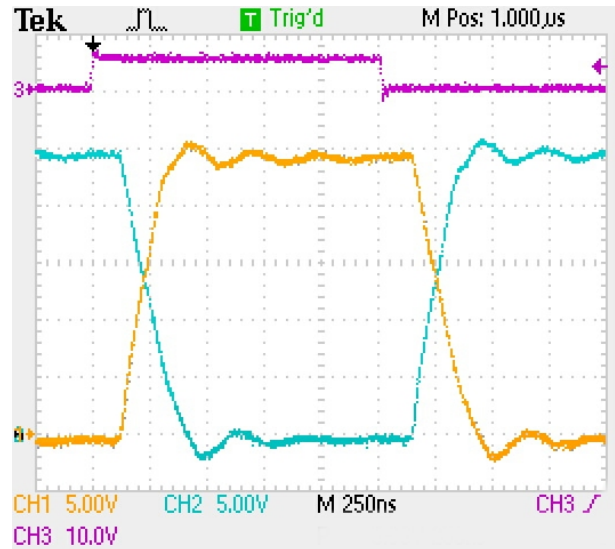

Figure 2: Example of typical line end signal without termination ($V_B = 24\text{ V}$, length of cable 10 m)

iC-Haus expressly reserves the right to change its products and/or specifications. An Infoletter gives details as to any amendments and additions made to the relevant current specifications on our internet website www.ichaus.de/infoletter; this letter is generated automatically and shall be sent to registered users by email.

Copying – even as an excerpt – is only permitted with iC-Haus approval in writing and precise reference to source.

iC-Haus does not warrant the accuracy, completeness or timeliness of the specification on this site and does not assume liability for any errors or omissions in the materials. The data specified is intended solely for the purpose of product description. No representations or warranties, either express or implied, of merchantability, fitness for a particular purpose or of any other nature are made hereunder with respect to information/specification or the products to which information refers and no guarantee with respect to compliance to the intended use is given. In particular, this also applies to the stated possible applications or areas of applications of the product.

iC-Haus conveys no patent, copyright, mask work right or other trade mark right to this product. iC-Haus assumes no liability for any patent and/or other trade mark rights of a third party resulting from processing or handling of the product and/or any other use of the product.

As a general rule our developments, IPs, principle circuitry and range of Integrated Circuits are suitable and specifically designed for appropriate use in technical applications, such as in devices, systems and any kind of technical equipment, in so far as they do not infringe existing patent rights. In principle the range of use is limitless in a technical sense and refers to the products listed in the inventory of goods compiled for the 2008 and following export trade statistics issued annually by the Bureau of Statistics in Wiesbaden, for example, or to any product in the product catalogue published for the 2007 and following exhibitions in Hanover (Hannover-Messe).

We understand suitable application of our published designs to be state-of-the-art technology which can no longer be classed as inventive under the stipulations of patent law. Our explicit application notes are to be treated only as mere examples of the many possible and extremely advantageous uses our products can be put to.

iC-HE

TRIPLE DIFFERENTIAL LINE DRIVER

preliminary



Rev A1, Page 6/6

ORDERING INFORMATION

Type	Package	Order Designation
iC-HE	SO14N	iC-HE SO14N

For technical support, information about prices and terms of delivery please contact:

iC-Haus GmbH
Am Kuemmerling 18
D-55294 Bodenheim
GERMANY

Tel.: +49 (61 35) 92 92-0
Fax: +49 (61 35) 92 92-192
Web: <http://www.ichaus.com>
E-Mail: sales@ichaus.com

Appointed local distributors: http://www.ichaus.com/sales_partners