

DESCRIPTION

STATEK's ultra-miniature, low profile CX-7-SM AT-cut crystals in leadless ceramic packages are designed for surface mounting on printed circuit boards or hybrid circuits. These crystals are low profile and have a very small land pattern. Maximum process temperature should not exceed 260°C.

FEATURES

- Designed for surface mount applications using infrared, vapor phase, wave solder or epoxy mount techniques
- Low profile (less than 1.2mm) hermetically sealed ceramic package
- Excellent aging characteristics
- Available with glass or ceramic lid
- High shock and vibration resistance
- Custom designs available
- Full military testing available
- Designed and manufactured in the USA

APPLICATIONS

Industrial, Computer & Communications

- General purpose clock oscillator
- PCMCIA
- Fax, Modem and LAN
- Smart card
- PDA and notebook computers
- Handheld instrumentation
- Cellular
- PCS

Military & Aerospace

- Airborne hybrid computer
- Military high speed modem
- MCM

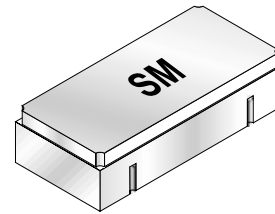

□ actual size
□ side view

PACKAGE DIMENSIONS

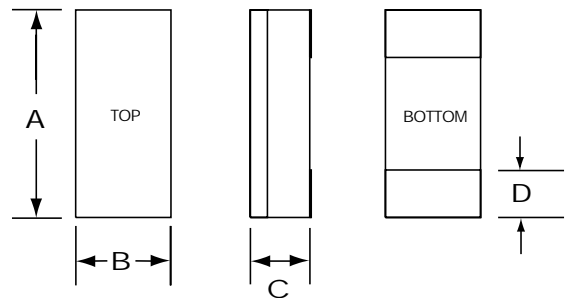

DIM	TYP.		MAX.	
	INCHES	mm	INCHES	mm
A	.157	4.00	.162	4.11
B	.072	1.83	.085	2.16
C	-	-	see below	
D	.035	0.89	.045	1.14
DIM "C"	GLASS LID		CERAMIC LID	
MAX	INCHES	mm	INCHES	mm
SM1	.045	1.14	.050	1.27
SM2	.046	1.17	.051	1.30
SM3	.048	1.22	.053	1.35

SUGGESTED LAND PATTERN

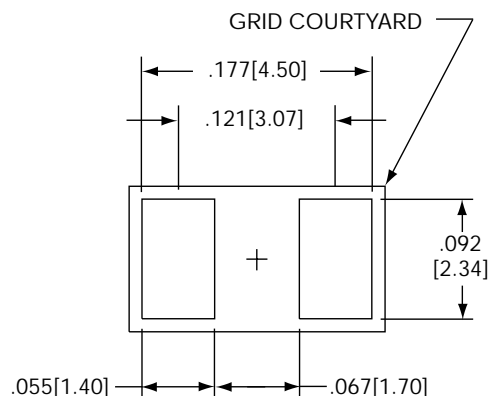

SPECIFICATIONS

Specifications are typical at 25°C unless otherwise noted.
Specifications are subject to change without notice.

	49 MHz
Motional Resistance R_1 (k Ω)	14
Motional Capacitance C_1 (fF)	2.4
Quality Factor Q (k)	100
Shunt Capacitance C_0 (pF)	0.8
Calibration Tolerance*	A \pm 0.01% (\pm 100ppm) B \pm 0.1% C \pm 1.0%
Load Capacitance	10pF (unless specified by customer)
Drive Level	200 μ W MAX.
Frequency-Temperature Stability**	-10°C to +70°C from \pm 10ppm -40°C to +85°C from \pm 35ppm -55°C to +125°C from \pm 50ppm
Aging, first year	5ppm MAX.
Shock, survival***	5,000g peak 0.3 msec., 1/2 sine
Vibration, survival	20g rms, 10-2,000 Hz random
Operating Temperature	-10°C to +70°C Commercial -40°C to +85°C Industrial -55°C to +125°C Military
Storage Temperature	-55°C to +125°C
Max Process Temperature	260°C for 20 sec.

Note: The characteristics of the frequency temperature stability follow that of AT-Cut thickness-shear mode.

* Tighter tolerances available as low as \pm 5 ppm

** Does not include calibration tolerance

*** Higher shock version available

TERMINATIONS

Designation	Termination
SM1	Gold Plated
SM2	Nickel, Solder Plated
SM3	Nickel, Solder Plated and Solder Dipped

PACKAGING

CX-7-SM	-Tray Pack (Standard) -16mm tape, 7" or 13" reels (Optional) Per EIA 481 (see data sheet 10109)
---------	---

EQUIVALENT CIRCUIT

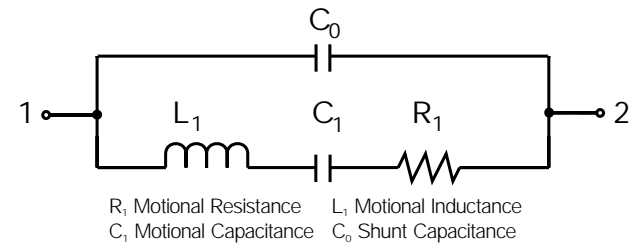

CONVENTIONAL CMOS PIERCE OSCILLATOR CIRCUIT

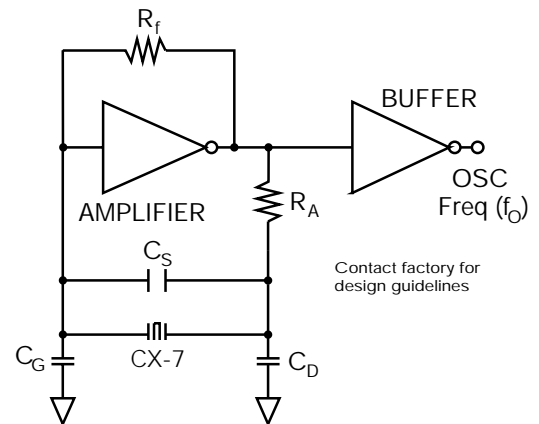

HOW TO ORDER CX-7-SM CRYSTALS

CX-7	SM1	49 MHz	(50 / 50 / 100 /)	
"S" if special or custom design.	SM1 SM2 SM3	Frequency	*Calibration Tolerance @25°C (A) (B) (C)	*Frequency Stability over Temp. Range
C=Ceramic Lid Blank=Glass Lid			Total Frequency Tolerance	Temp. Range: C = Commercial I = Industrial M = Military S = Specify

*Other calibration fill in ppm.

10155 - Rev A