

E_T-1W & F_T-1W Series

1W, FIXED INPUT, ISOLATED & UNREGULATED DUAL/SINGLE OUTPUT DC-DC CONVERTER

multi-country patent protection **RoHS** **US**

FEATURES

- Small Footprint
- SMD Package Style
- 3KVDC Isolation
- Temperature Range: -40°C to +85°C
- No Heat sink Required
- Industry Standard Pinout
- Internal SMD construction
- No External Component Required
- RoHS Compliance

APPLICATIONS

The E_T-1W&F_T-1W Series are specially designed for applications where a group of polar power supplies are isolated from the input power supply in a distributed power supply system on a circuit board.

These products apply to:

- 1) Where the voltage of the input power supply is fixed (voltage variation $\leq \pm 10\%$);
- 2) Where isolation is necessary between input and output (isolation voltage $\leq 3000\text{VDC}$);
- 3) Where the regulation of the output voltage and the output ripple noise are not demanding.

Such as: purely digital circuits, ordinary low frequency analog circuits, and IGBT power device driving circuits.

MODEL SELECTION

F0505T-1W

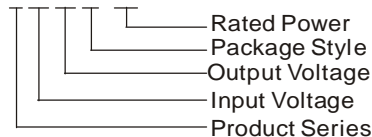

MORNSUN Science& Technology co.,Ltd.

Address: 2th floor 6th building, Huangzhou Industrial District, Guangzhou, China
 Tel: 86-20-38601850
 Fax: 86-20-38601272
[Http://www.mornsun-power.com](http://www.mornsun-power.com)

PRODUCT PROGRAM

Part Number	Input		Output			Efficiency (% , Typ.)	Certificate		
	Voltage (VDC)		Voltage (VDC)	Current (mA)					
	Nominal	Range		Max	Min				
F0303T-1W	3.3	3.0-3.6	3.3	304	30	73			
F0305T-1W			5	200	20	75			
F0505T-1W	5	4.5-5.5	5	200	20	70	UL		
F0509T-1W			9	110	11	76	UL		
F0512T-1W			12	84	9	78	UL		
F0515T-1W			15	66	7	79	UL		
E0505T-1W			± 5	± 100	± 10	71	UL		
E0509T-1W			± 9	± 55	± 6	77	UL		
E0512T-1W			± 12	± 42	± 5	78	UL		
E0515T-1W			± 15	± 33	± 4	79	UL		
F1205T-1W			12	10.8-13.2	5	200	20	69	UL
F1209T-1W					9	110	11	73	UL
F1212T-1W	12	84			9	73	UL		
F1215T-1W	15	66			7	74	UL		
E1205T-1W	± 5	± 100			± 10	71	UL		
E1209T-1W	± 9	± 55			± 6	73	UL		
E1212T-1W	± 12	± 42			± 5	74	UL		
E1215T-1W	± 15	± 33			± 4	75	UL		

Note: The E_T-W2/F_T-W2 series also are available in our company.

ISOLATION SPECIFICATIONS

Item	Test Conditions	Min	Typ	Max	Units
Isolation voltage	Tested for 1 minute and 1mA max	3000			VDC
Isolation resistance	Test at 500VDC	1000			MΩ

OUTPUT SPECIFICATIONS

Item	Test Conditions	Min	Typ.	Max	Units
Output power		0.1		1	W
Line regulation	For Vin change of 1%(3.3V output)			± 1.5	%
	For Vin change of 1%(Others output)			± 1.2	
Load regulation	10% to 100% load 3.3V output		15	20	%
	10% to 100% load 5V output		12.8	15	
	10% to 100% load 9V output		8.3	10	
	10% to 100% load 12V output		6.8	10	
	10% to 100% load 15V output		6.3	10	
Output voltage accuracy		See tolerance envelope graph			
Temperature drift	100% full load			0.03	%/°C
Output ripple & Noise*	20MHz Bandwidth	E_T-1W series	50	75	mVp-p
		F_T-1W series	75	100	
Switching frequency	Full load, nominal input		100		KHz

*Test ripple and noise by "parallel cable" method. See detailed operation instructions at Testing of Power Converter section, application notes.

Note:

1. All specifications measured at $T_A=25^\circ\text{C}$, humidity<75%, nominal input voltage and rated output load unless otherwise specified.
2. See below recommended circuits for more details.

COMMON SPECIFICATIONS					
Item	Test Conditions	Min	Typ	Max	Units
Storage humidity				95	%
Operating temperature		-40		85	°C
Storage temperature		-55		125	
Temp. rise at full load			15	25	
Lead temperature	1.5mm from case for 10 seconds			260	
Cooling		Free air convection			
Package material		Epoxy Resin(UL94-V0)			
Short circuit protection*				1	Second
MTBF		3500			K hours
Weight				1.71	g

*Supply voltage must be discontinued at the end of short circuit duration.

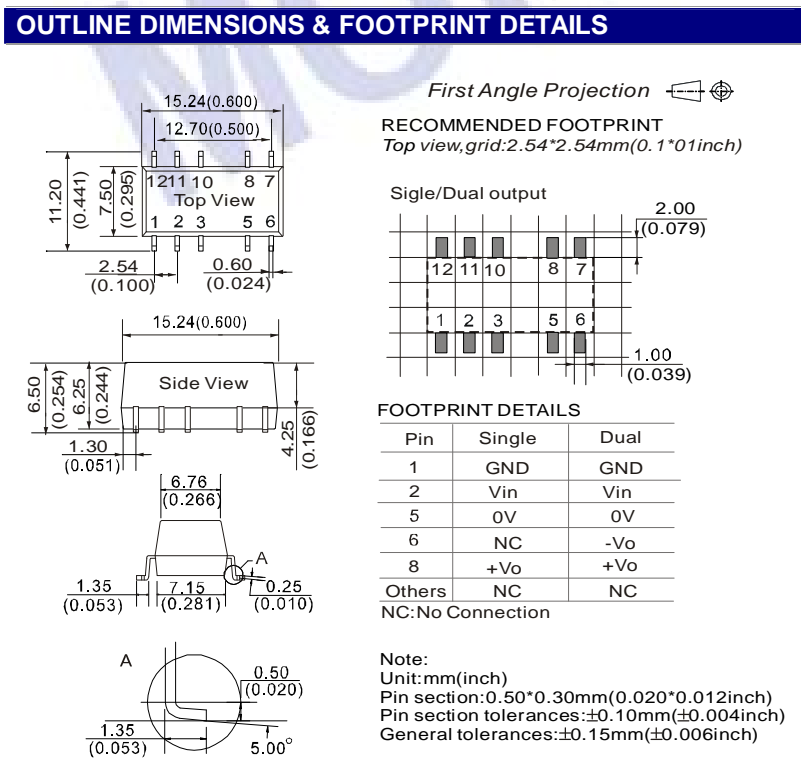
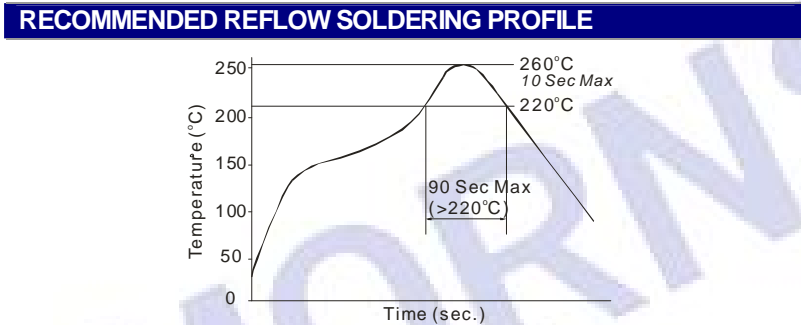
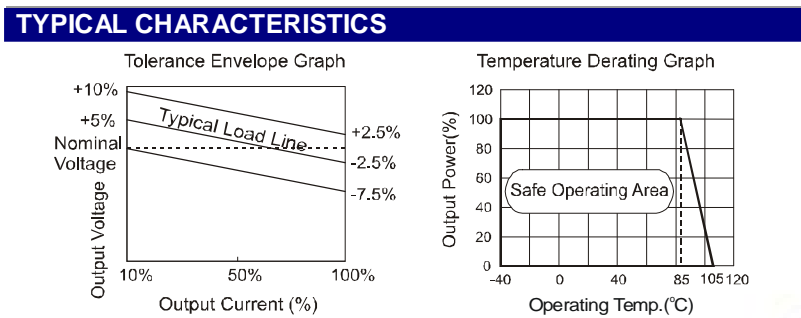

APPLICATION NOTE

Requirement on output load

To ensure this module can operate efficiently and reliably, During operation, the minimum output load is **not less than 10%** of the full load, and that **this product should never be operated under no load!** If the actual output power is very small, please connect a resistor with proper resistance at the output end in parallel to increase the load, or use our company's products with a lower rated output power (E_T-W2/F_T-W2 Series).

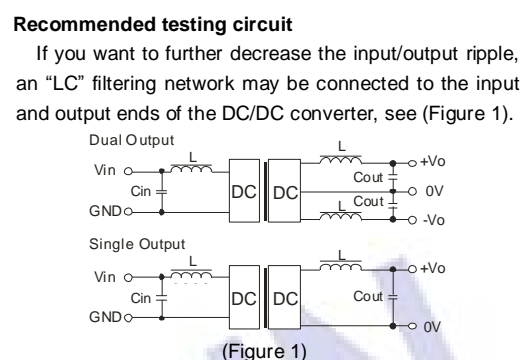

It should also be noted that the inductance and the frequency of the "LC" filtering network should be staggered with the DC/DC frequency to avoid mutual interference. However, the capacitance of the output filter capacitor must be proper. If the capacitance is too big, a startup problem might arise. For every channel of output, provided the safe and reliable operation is ensured, the greatest capacitance of its filter capacitor sees (Table 1).

EXTERNAL CAPACITOR TABLE (Table 1)

Vin (VDC)	Cin (uF)	Single Vout (VDC)	Cout (uF)	Dual Vout (VDC)	Cout (uF)
3.3/5	4.7	5	10	±3.3/5	4.7
12	2.2	9	4.7	±9	2.2
-	-	12	2.2	±12	1
-	-	15	1	±15	1

It's not recommended to connect any external capacitor in the application field with less than 0.5 watt output.

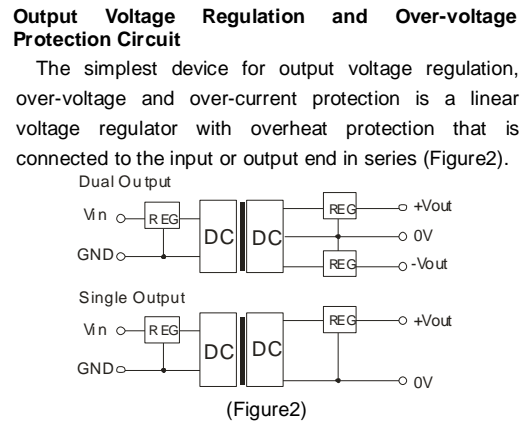

Overload Protection

Under normal operating conditions, the output circuit of these products has no protection against overload. The simplest method is to connect a self-recovery fuse in series at the input end or add a circuit breaker to the circuit.

No parallel connection or plug and play.