

3-PIN MICROPROCESSOR RESET CIRCUIT**AZ809A****General Description**

The AZ809A is a precision system supervisor and reset circuit designed to monitor the power supplies in microprocessor and digital system. It provides a reset signal to the host processor during power-up, power-down, and brownout conditions.

The AZ809A has an active-low RESET output, three standard reset options are offered to support 5V, 3.3V, and 3.0V system. Whenever the system supply voltage declines below the internal fixed reset threshold, the AZ809A asserts a reset signal and the reset signal remains asserted for 240mS after V_{CC} rises above the threshold.

The AZ809A has a push-pull output, no external components are required. The output is guaranteed to be in the correct state at V_{CC} level as low as 1V. The AZ809A is optimized to reject fast transient glitches on the VCC line. When the V_{CC} is 3.3V, the supply current consumption is about 6 μ A typically.

The IC is available in SOT-23 package.

Features

- Precise Monitoring of 3.0V, 3.3V, and 5.0V Supply Voltages
- 140ms Minimum Reset Pulse Width
- Active-low $\overline{\text{RESET}}$ Output
- Push-Pull $\overline{\text{RESET}}$ Output
- No External Components
- Reset Valid Down to $V_{CC}=1.0V$
- Power Supply Fast Transient Immunity
- Specified Over Full Temperature Range: -40 to 105°C

Applications

- Microprocessor Systems
- Portable/Battery-Powered Systems
- Embedded Controllers
- Automotive
- Intelligent Instruments
- Wireless Communication Systems
- PDAs and Handheld Equipment
- Set-Top Boxes
- ADSL Modems



Figure 1. Package Type of AZ809A

3-PIN MICROPROCESSOR RESET CIRCUIT
AZ809A
Pin Configuration

Figure 2. Pin Configuration of AZ809A (Top View)

Pin Description

Pin Number	Pin Name	Function
1	GND	Ground pin
2	$\overline{\text{RESET}}$	Active low output. The $\overline{\text{RESET}}$ is asserted LOW if V_{CC} falls below the reset threshold and remains LOW for the 240ms typical reset timeout period (140ms minimum) after V_{CC} exceeds the threshold
3	VCC	Power supply input voltage (3.0V, 3.3V, 5.0V)

3-PIN MICROPROCESSOR RESET CIRCUIT
AZ809A
Functional Block Diagram

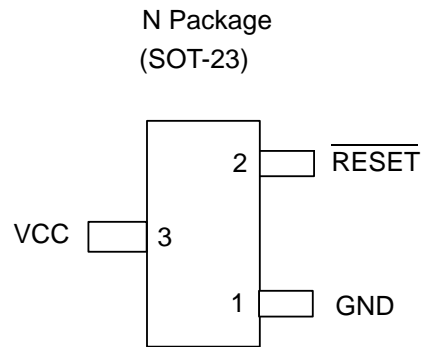
Figure 3. Functional Block Diagram of AZ809A

Ordering Information

Package	Temperature Range	Reset Threshold	Part Number	Marking ID	Packing Type
SOT-23	-40 to 105°C	4.63V	AZ809ANLTR-E1	EH7	Tape & Reel
		2.93V	AZ809ANSTR-E1	EH1	
		2.63V	AZ809ANRTR-E1	EH6	

BCD Semiconductor's Pb-free products, as designated with "E1" suffix in the part number, are RoHS compliant.

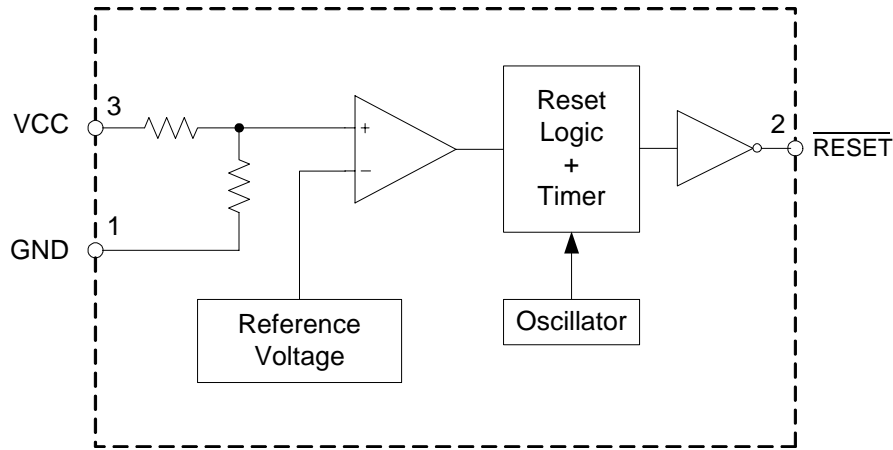
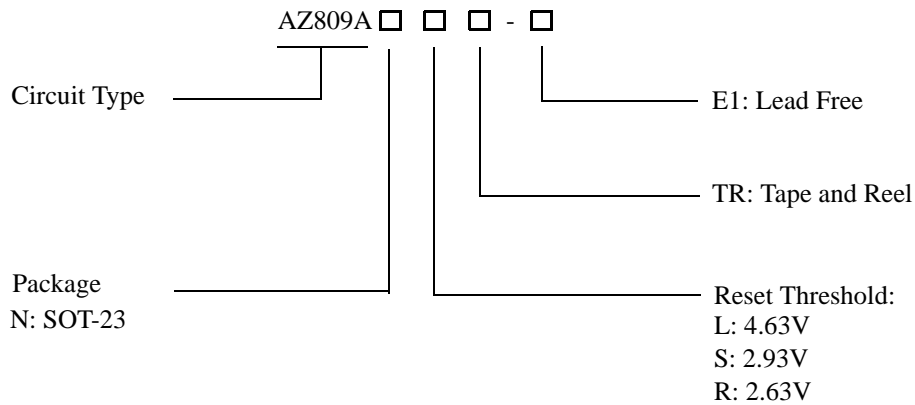
**3-PIN MICROPROCESSOR RESET CIRCUIT****AZ809A****Absolute Maximum Ratings (Note 1)**

Parameter	Symbol	Value	Unit
Supply Voltage	V_{CC}	-0.3 to 6	V
$\overline{\text{RESET}}$		-0.3 to $V_{CC}+0.3$	V
Input Current, V_{CC} Pin		20	mA
Output Current, $\overline{\text{RESET}}$ Pin		20	mA
Rate of Rise, V_{CC}		100	V/ μ s
Continuous Power Dissipation		320	mW
Junction Temperature	T_J	150	$^{\circ}$ C
Storage Temperature	T_{STG}	-65 to 150	$^{\circ}$ C
Lead Temperature (Soldering, 10sec)	T_{LEAD}	260	$^{\circ}$ C
ESD (Human Body Model)		6000	V
ESD (Machine Model)		400	V

Note 1: Stresses greater than those listed under "Absolute Maximum Ratings" may cause permanent damage to the device. These are stress ratings only, and functional operation of the device at these or any other conditions beyond those indicated under "Recommended Operating Conditions" is not implied. Exposure to "Absolute Maximum Ratings" for extended periods may affect device reliability.

Recommended Operating Conditions

Parameter	Symbol	Min	Max	Unit
Supply Voltage	V_{CC}	1	5.5	V
Operating Ambient Temperature Range	T_A	-40	105	$^{\circ}$ C



3-PIN MICROPROCESSOR RESET CIRCUIT

AZ809A

Electrical Characteristics

(V_{CC} is over the full voltage range, $T_A=-40^{\circ}C$ to $105^{\circ}C$, unless otherwise noted.

Typical values at $T_A=25^{\circ}C$, $V_{CC}=5V$ for L device, $V_{CC}=3.3V$ for S device and $V_{CC}=3V$ for R device.)(Note 2)

Parameter	Symbol	Conditions	Min	Typ	Max	Unit	
Input Voltage (V_{CC}) Range	V_{CC}	$T_A=0^{\circ}C$ to $85^{\circ}C$	1.0		5.5	V	
		$T_A=-40^{\circ}C$ to $105^{\circ}C$	1.2		5.5		
Supply Current	I_{CC}	L Devices	$T_A=-40^{\circ}C$ to $85^{\circ}C$, $V_{CC}<5.5V$		7	11	μA
			$T_A=-40^{\circ}C$ to $105^{\circ}C$, $V_{CC}<5.5V$			12	
		R/S Devices	$T_A=-40^{\circ}C$ to $85^{\circ}C$, $V_{CC}<3.6V$		6	10	
			$T_A=-40^{\circ}C$ to $105^{\circ}C$, $V_{CC}<3.6V$			11	
Reset Threshold	V_{TH}	L Devices	$T_A=25^{\circ}C$	4.56	4.63	4.70	V
			$T_A=-40^{\circ}C$ to $85^{\circ}C$	4.50		4.75	
			$T_A=-40^{\circ}C$ to $105^{\circ}C$	4.40		4.86	
		S Devices	$T_A=25^{\circ}C$	2.89	2.93	2.96	
			$T_A=-40^{\circ}C$ to $85^{\circ}C$	2.85		3.00	
			$T_A=-40^{\circ}C$ to $105^{\circ}C$	2.78		3.08	
		R Devices	$T_A=25^{\circ}C$	2.59	2.63	2.66	
			$T_A=-40^{\circ}C$ to $85^{\circ}C$	2.55		2.70	
			$T_A=-40^{\circ}C$ to $105^{\circ}C$	2.50		2.76	
Reset Threshold Temperature Coefficient		$T_A=-40^{\circ}C$ to $105^{\circ}C$		30		ppm/ $^{\circ}C$	
VCC to Reset Delay		$V_{CC}=V_{TH}$ to $V_{TH}-100mV$		20		μs	
Reset Active Timeout Period		$T_A=-40^{\circ}C$ to $85^{\circ}C$	140	240	560	ms	
		$T_A=-40^{\circ}C$ to $105^{\circ}C$	100		840		
Low \overline{RESET} Output Voltage	V_{OL}	R/S Devices	$V_{CC}=V_{TH}(min)$, $I_{SINK}=1.2mA$		0.3	V	
		L Devices	$V_{CC}=V_{TH}(min)$, $I_{SINK}=3.2mA$		0.4		
			$V_{CC}>1.1V$, $I_{SINK}=50\mu A$		0.3		
High \overline{RESET} Output Voltage	V_{OH}	R/S Devices	$V_{CC}>V_{TH}(max)$, $I_{SOURCE}=500\mu A$	$0.8V_{CC}$		V	
		L Devices	$V_{CC}>V_{TH}(max)$, $I_{SOURCE}=800\mu A$	$V_{CC}-1.5$			

Note 2. Production testing done at $T_A=25^{\circ}C$. Over temperature specifications guaranteed by design only.



3-PIN MICROPROCESSOR RESET CIRCUIT

AZ809A

Typical Performance Characteristics

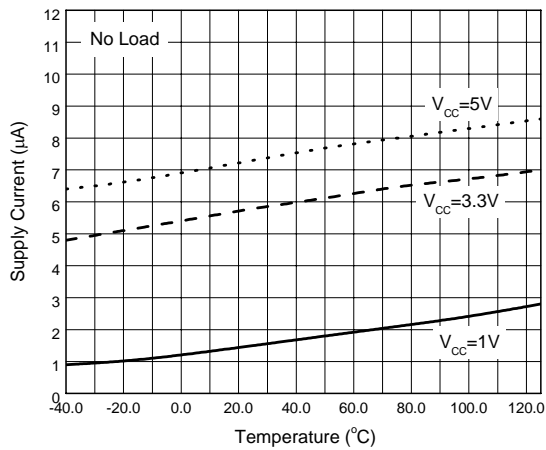

Figure 4. Supply Current vs. Temperature

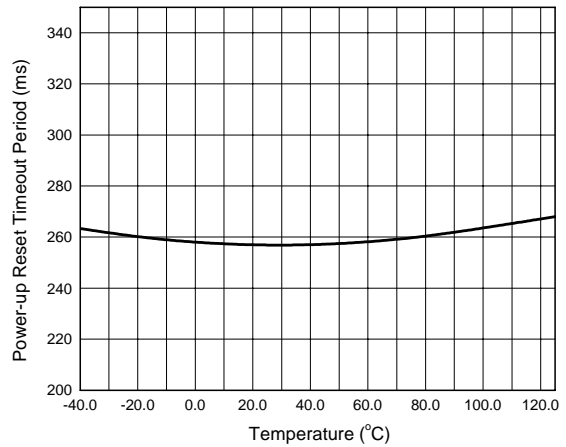

Figure 5. Power-up Reset Timeout vs. Temperature

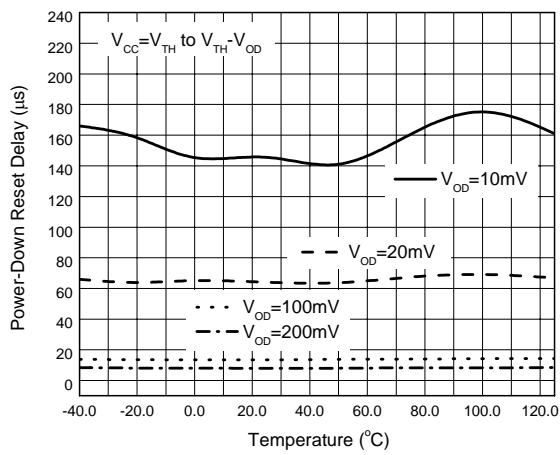

Figure 6. Power-down Reset Delay vs. Temperature

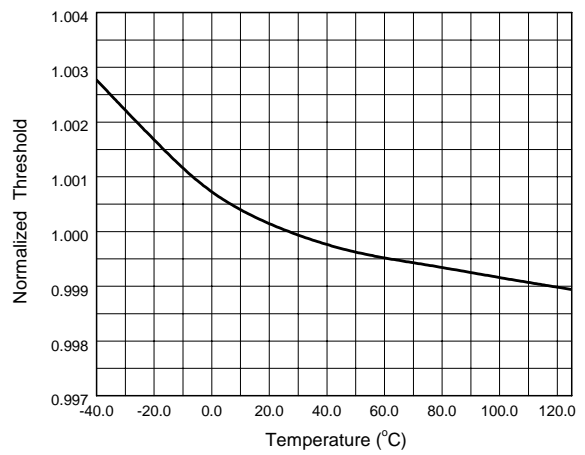

Figure 7. Normalized Reset Threshold vs. Temperature



3-PIN MICROPROCESSOR RESET CIRCUIT

AZ809A

Typical Performance Characteristics (Continued)

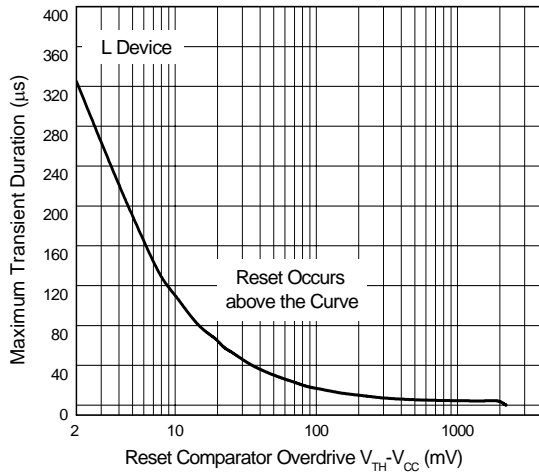

Figure 8. Maximum Transient Duration NOT Causing a Reset Pulse vs. Reset Comparator Overdrive

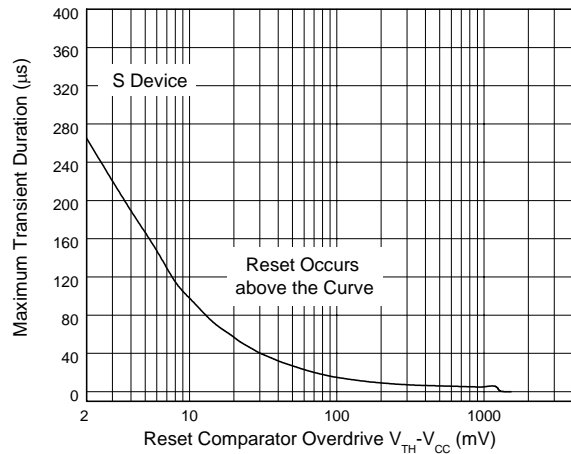

Figure 9. Maximum Transient Duration NOT Causing a Reset Pulse vs. Reset Comparator Overdrive

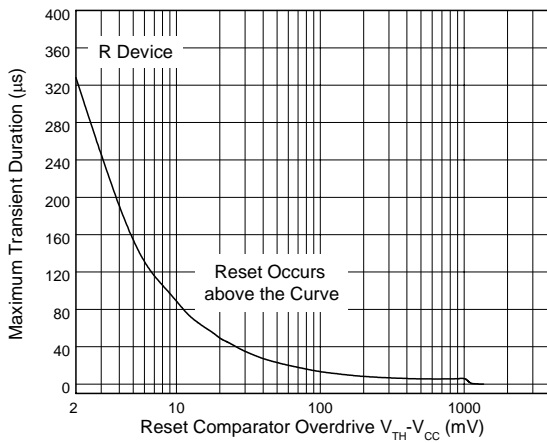
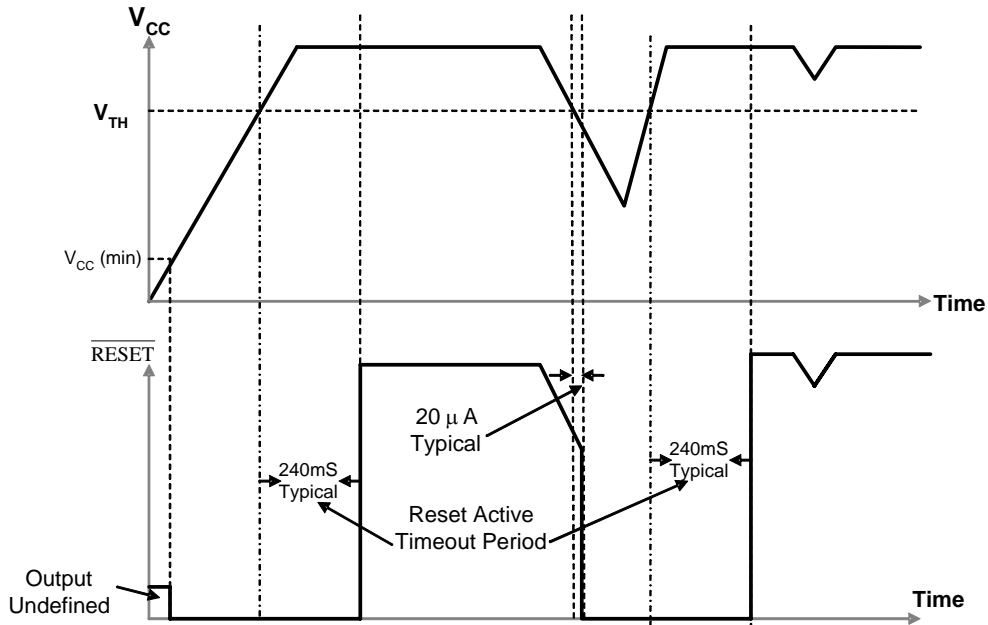

Figure 10. Maximum Transient Duration NOT Causing a Reset Pulse vs. Reset Comparator Overdrive

Operating Diagram

The AZ809A asserts a reset signal LOW whenever the V_{CC} supply voltage is below the threshold voltage and remains asserted for 240ms typically after the V_{CC} has risen above the threshold.

Figure 11. Reset Timing Diagram of AZ809A

Application Information
Valid $\overline{\text{RESET}}$ with V_{CC} under 1.0 V

The AZ809A $\overline{\text{RESET}}$ output is valid to V_{CC}=1.0V. Below this voltage, the output becomes an open circuit and doesn't sink current. Therefore, high-impedance CMOS logic input connected to $\overline{\text{RESET}}$ can drift to undetermined voltages.

To ensure that the AZ809A $\overline{\text{RESET}}$ is in a known state when V_{CC} is under 1.0V, a 100KΩ pull-down resistor between the $\overline{\text{RESET}}$ pin and GND is recommended to discharge stray capacitances and maintain the output low.

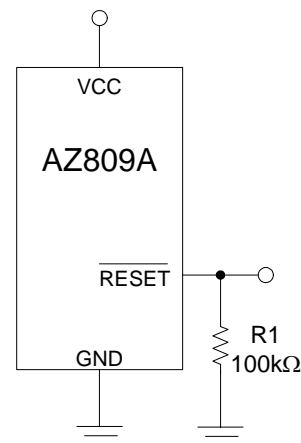
 Figure 12. $\overline{\text{RESET}}$ Valid to V_{CC}=0V

Application Information (Continued)

Negative Going V_{CC} Transient

The AZ809A is optimized to immune fast negative-going transients or glitches on the V_{CC} line, and the sensitivity depends on the duration of the transient and the magnitude of the undershoot below the reset threshold (reset comparator overdrive). Figure 13 shows the maximum pulse width of a negative-going V_{CC} transient that will not cause a reset pulse. As the magnitude of the transient increases (goes farther below the reset threshold), the maximum allowable pulse width decreases. Any combination of duration and overdrive that lies under the curve will not generate a reset signal, typically, a V_{CC} transient that goes 100mV below the reset threshold and lasts about 20 μ s or less will not cause a reset pulse.

A 0.1 μ F bypass capacitor mounted as close as possible to the V_{CC} pin will provide additional transient rejection.

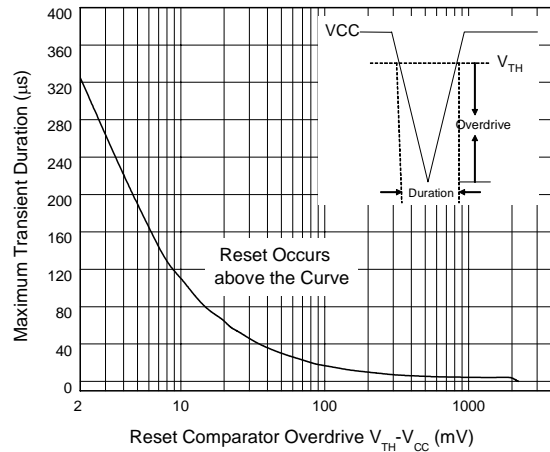

Figure 13. Maximum Transient Duration NOT Causing a Reset Pulse vs. Reset Comparator Overdrive

Typical Application

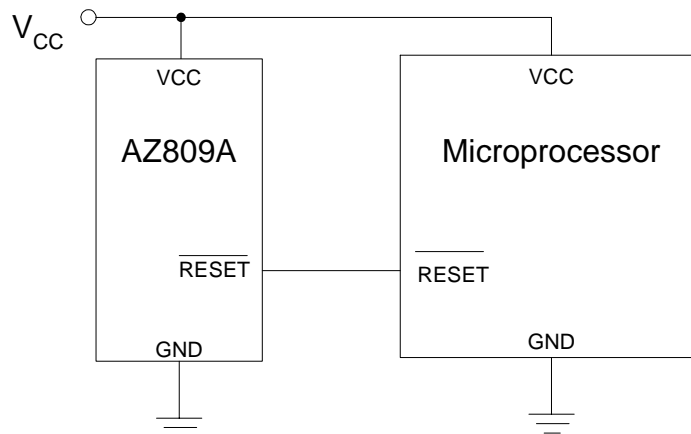

Figure 14. Typical Application of AZ809A



3-PIN MICROPROCESSOR RESET CIRCUIT

AZ809A

Mechanical Dimensions

SOT-23

Unit: mm(inch)

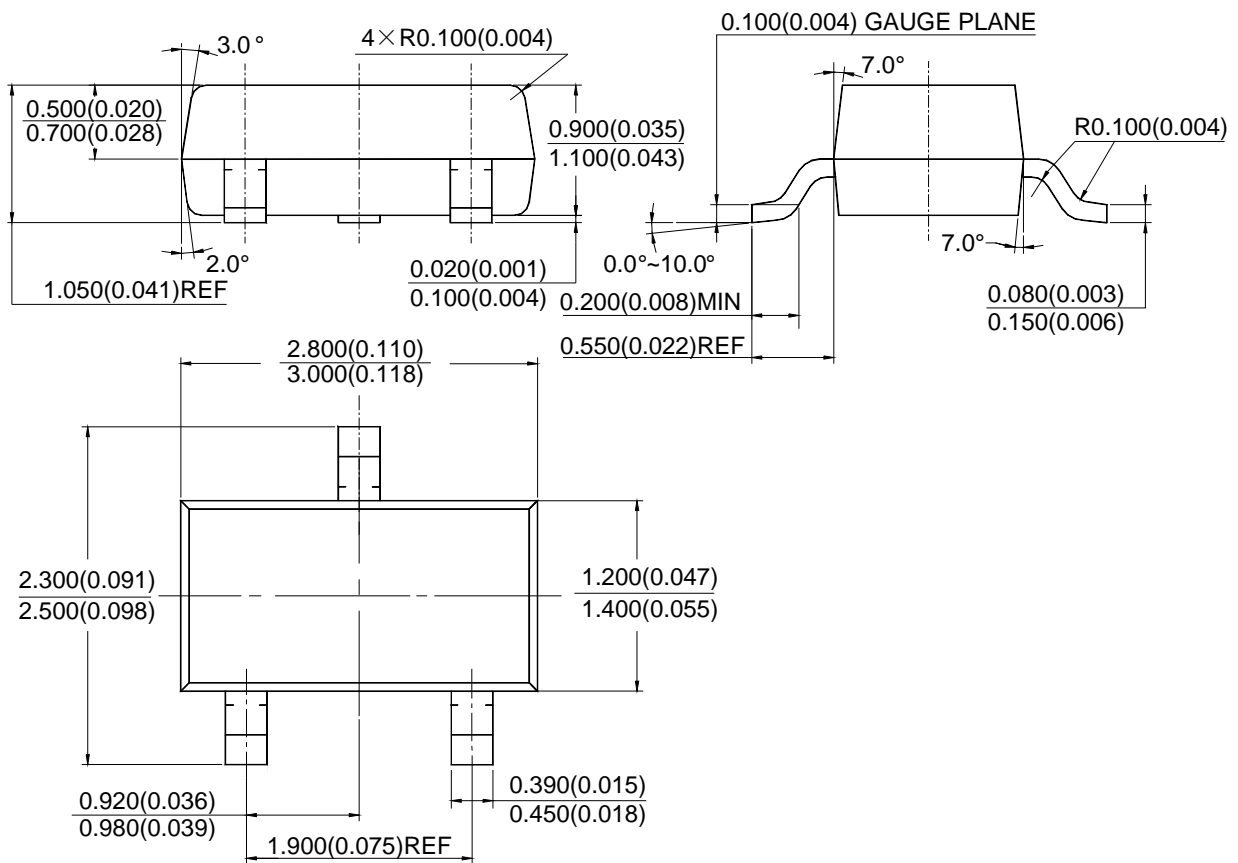



BCD Semiconductor Manufacturing Limited

<http://www.bcdsemi.com>

IMPORTANT NOTICE

BCD Semiconductor Manufacturing Limited reserves the right to make changes without further notice to any products or specifications herein. BCD Semiconductor Manufacturing Limited does not assume any responsibility for use of any its products for any particular purpose, nor does BCD Semiconductor Manufacturing Limited assume any liability arising out of the application or use of any its products or circuits. BCD Semiconductor Manufacturing Limited does not convey any license under its patent rights or other rights nor the rights of others.

MAIN SITE

BCD Semiconductor Manufacturing Limited
- Wafer Fab
Shanghai SIM-BCD Semiconductor Manufacturing Limited
800, Yi Shan Road, Shanghai 200233, China
Tel: +86-21-6485 1491, Fax: +86-21-5450 0008

BCD Semiconductor Manufacturing Limited
- IC Design Group
Advanced Analog Circuits (Shanghai) Corporation
8F, Zone B, 900, Yi Shan Road, Shanghai 200233, China
Tel: +86-21-6495 9539, Fax: +86-21-6485 9673

REGIONAL SALES OFFICE

Shenzhen Office
Shanghai SIM-BCD Semiconductor Manufacturing Co., Ltd. Shenzhen Office
Advanced Analog Circuits (Shanghai) Corporation Shenzhen Office
Room E, 5F, Noble Center, No.1006, 3rd Fuzhong Road, Futian District, Shenzhen 518026, China
Tel: +86-755-8826 7951
Fax: +86-755-8826 7865

Taiwan Office
BCD Semiconductor (Taiwan) Company Limited
4F, 298-1, Rui Guang Road, Nei-Hu District, Taipei, Taiwan
Tel: +886-2-2656 2808
Fax: +886-2-2656 2806

USA Office
BCD Semiconductor Corporation
30920 Huntwood Ave. Hayward, CA 94544, U.S.A
Tel : +1-510-324-2988
Fax: +1-510-324-2788