

**CONNECTOR
DESIGNATOR**

J

DIRECT COUPLING

620JS001 M 18

Basic Part No. _____

Finish (Table II) _____

Shell Size _____

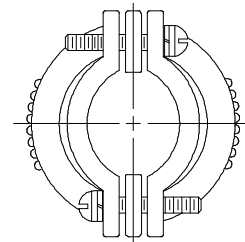
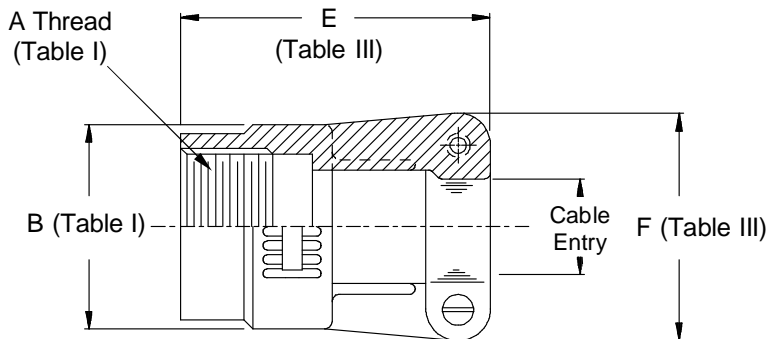

See inside back cover fold-out or pages 13 and 14 for Tables I and II.

TABLE III: CABLE ENTRY						
Shell Size	E		F		Cable Entry Max	
08	1.340	(34.0)	.750	(19.1)	.125	(3.2)
10	1.340	(34.0)	.937	(23.8)	.250	(6.4)
14	1.340	(34.0)	1.125	(28.6)	.500	(12.7)
16	1.340	(34.0)	1.187	(30.1)	.625	(15.9)
18	1.340	(34.0)	1.312	(33.3)	.750	(19.1)
20	1.420	(36.1)	1.437	(36.5)	.875	(22.2)
22	1.420	(36.1)	1.562	(39.7)	1.000	(25.4)
24	1.420	(36.1)	1.687	(42.8)	1.125	(28.6)

1. Cable Entry is defined as the accommodation entry for the wire bundle or cable. Dimensions are not intended for inspection criteria.
2. Metric dimensions (mm) are indicated in parentheses.