

**STRUCTURE** Silicon Monolithic Integrated Circuit  
**PRODUCT NAME** Overvoltage Protection Controller with Internal FET

**MODEL NAME** **BD6041GUL**

- FEATURES**
- Overvoltage Protection up to 28V
  - Internal Low Ron (125mΩ) FET
  - Over voltage Lockout (OVLO)
  - Under voltage Lockout(UVLO)
  - Internal 2msec Startup Delay
  - Over Current Protect
  - Thermal Shut Down
  - Small package: VCSP50L1(1.6mm x 1.6mm, height=0.55mm)

● Absolute maximum ratings (Ta=25°C)

| Contents                    | Symbol | Rating   | Unit | Conditions |
|-----------------------------|--------|----------|------|------------|
| Input supply voltage 1      | Vmax1  | -0.3~30  | V    | IN         |
| Input supply voltage 2      | Vmax2  | -0.3~7   | V    | other      |
| Power dissipation           | Pd     | 725      | mW   |            |
| Operating temperature range | Topr   | -35~+85  | °C   |            |
| Storage temperature range   | Tstr   | -55~+150 | °C   |            |

※1 When using more than at Ta=25°C, it is reduced 5.8 mW per 1°C.  
 ROHM specification board 50mm×58mm mounting.

● Operating range (Ta=-35~+85°C)

| Parameter           | Symbol          | Range  | Unit | Usage |
|---------------------|-----------------|--------|------|-------|
| Input voltage range | V <sub>in</sub> | 2.2~28 | V    |       |

※ This product is not especially designed to be protected from radioactivity.

**Status of this document.**

The Japanese version of this document is the formal specification.

A customer may use this translation version only for reference to help reading the formal version.

If there are any differences in translation version of this document, formal version takes priority.

● **Electrical Characteristics**

(Unless otherwise noted, Ta = 25°C, IN=5V)

| Parameter                        | Symbol | Rating |      |      | Unit | Conditions    |
|----------------------------------|--------|--------|------|------|------|---------------|
|                                  |        | Min.   | Typ. | Max. |      |               |
| ● ELECTRICAL                     |        |        |      |      |      |               |
| Input Voltage Range              | VIN    | -      | -    | 28   | V    |               |
| Supply Quiescent Current         | ICC    |        | 45   | 90   | μA   |               |
| Under Voltage Lockout            | UVLO   | 2.53   | 2.65 | 2.77 | V    | IN=decreasing |
| Under Voltage Lockout Hysteresis | UVLOh  | 50     | 100  | 150  | mV   | IN=increasing |
| Over Voltage Lockout             | OVLO   | 5.7    | 5.85 | 6.0  | V    | IN=increasing |
| Over Voltage Lockout Hysteresis  | OVLOh  | 50     | 100  | 150  | mV   | IN=decreasing |
| Current limit                    | ILM    | 1.2    | -    | -    | A    |               |
| Vin vs. Vout Res.                | RON    | -      | 125  | 150  | mΩ   |               |
| OK Output Low Voltage            | OKVO   | -      | -    | 400  | mV   | SINK=1mA      |
| OK Leakage Current               | OKleak | -      | -    | 1    | μA   |               |
| EN input voltage (H)             | ENH    | 1.45   | -    | -    | V    |               |
| EN input voltage (L)             | ENL    | -      | -    | 0.5  | V    |               |
| EN input current                 | ENC    | 12     | 25   | 50   | μA   | EN=1.5V       |
| ● TIMINGS                        |        |        |      |      |      |               |
| Start Up Delay                   | Ton    | -      | 2    | 4    | msec |               |
| OK Going Up Delay                | Tok    | -      | 10   | 15   | msec |               |
| Output Turn Off Time             | Toff   | -      | 2    | 10   | μsec |               |
| Alert Delay                      | Tovp   | -      | 1.5  | 10   | μsec |               |

\* This product is not especially designed to be protected from radioactivity.

● **Block Diagram**

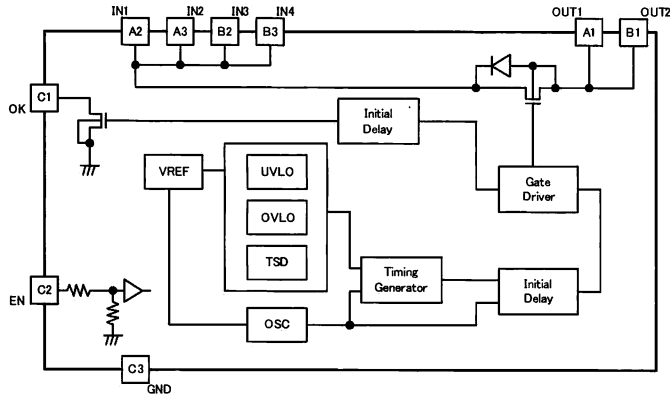

● **PIN number/PIN name**

| Pin number | Pin name |
|------------|----------|
| A2         | IN1      |
| A3         | IN2      |
| B2         | IN3      |
| B3         | IN4      |
| A1         | OUT1     |
| B1         | OUT2     |
| C3         | GND      |
| C1         | OK       |
| C2         | EN       |

● **PIN DESCRIPTIONS**

| PIN              | NAME           | FUNCTION   |
|------------------|----------------|--|
| A2, A3<br>B2, B3 | IN1, 2<br>3, 4 | Input voltage Pin. A 1 $\mu$ F low ESR capacitor, or larger must be connected between this pin and GND |
| A1, B1           | OUT1, 2        | Output Voltage Pin   |
| C1               | OK             | Active-low open drain output to signal if the adapter voltage is correct                               |
| C3               | GND            | Ground Pin   |
| C2               | EN             | Enable input Drive EN high to turn off OUT (Hi-z output)   |

● **Package Dimensions (VCSP50L1)**

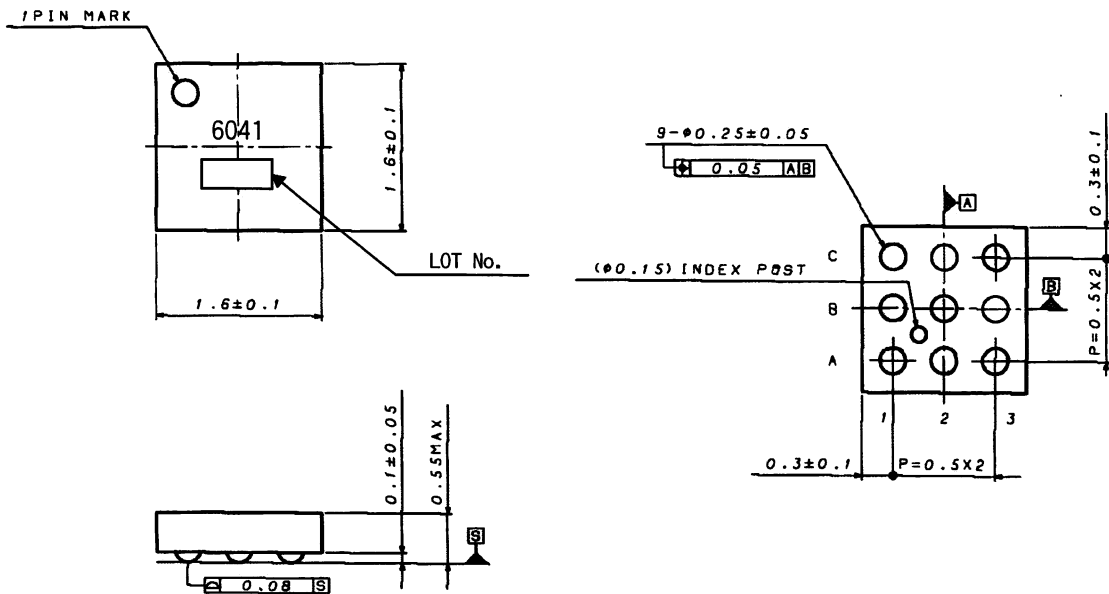

## ● Use-related Cautions

### (1) Absolute maximum ratings

If applied voltage (VDD, VIN), operating temperature range (Topr), or other absolute maximum ratings are exceeded, there is a risk of damage. Since it is not possible to identify short, open, or other damage modes, if special modes in which absolute maximum ratings are exceeded are assumed, consider applying fuses or other physical safety measures.

### (2) Recommended operating range

This is the range within which it is possible to obtain roughly the expected characteristics. For electrical characteristics, it is those that are guaranteed under the conditions for each parameter. Even when these are within the recommended operating range, voltage and temperature characteristics are indicated.

### (3) Reverse connection of power supply connector

There is a risk of damaging the LSI by reverse connection of the power supply connector. For protection from reverse connection, take measures such as externally placing a diode between the power supply and the power supply pin of the LSI.

### (4) Power supply lines

In the design of the board pattern, make power supply and GND line wiring low impedance.

When doing so, although the digital power supply and analog power supply are the same potential, separate the digital power supply pattern and analog power supply pattern to deter digital noise from entering the analog power supply due to the common impedance of the wiring patterns. Similarly take pattern design into account for GND lines as well.

Furthermore, for all power supply pins of the LSI, in conjunction with inserting capacitors between power supply and GND pins, when using electrolytic capacitors, determine constants upon adequately confirming that capacitance loss occurring at low temperatures is not a problem for various characteristics of the capacitors used.

### (5) GND voltage

Make the potential of a GND pin such that it will be the lowest potential even if operating below that. In addition, confirm that there are no pins for which the potential becomes less than a GND by actually including transition phenomena.

### (6) Shorts between pins and misinstallation

When installing in the set board, pay adequate attention to orientation and placement discrepancies of the LSI. If it is installed erroneously, there is a risk of LSI damage. There also is a risk of damage if it is shorted by a foreign substance getting between pins or between a pin and a power supply or GND.

### (7) Operation in strong magnetic fields

Be careful when using the LSI in a strong magnetic field, since it may malfunction.

### (8) Inspection in set board

When inspecting the LSI in the set board, since there is a risk of stress to the LSI when capacitors are connected to low impedance LSI pins, be sure to discharge for each process. Moreover, when getting it on and off of a jig in the inspection process, always connect it after turning off the power supply, perform the inspection, and remove it after turning off the power supply. Furthermore, as countermeasures against static electricity, use grounding in the assembly process and take appropriate care in transport and storage.

### (9) Input pins

Parasitic elements inevitably are formed on an LSI structure due to potential relationships. Because parasitic elements operate, they give rise to interference with circuit operation and may be the cause of malfunctions as well as damage. Accordingly, take care not to apply a lower voltage than GND to an input pin or use the LSI in other ways such that parasitic elements operate. Moreover, do not apply a voltage to an input pin when the power supply voltage is not being applied to the LSI. Furthermore, when the power supply voltage is being applied, make each input pin a voltage less than the power supply voltage as well as within the guaranteed values of electrical characteristics.

### (10) Ground wiring pattern

When there is a small signal GND and a large current GND, it is recommended that you separate the large current GND pattern and small signal GND pattern and provide single point grounding at the reference point of the set so that voltage variation due to resistance components of the pattern wiring and large currents do not cause the small signal GND voltage to change. Take care that the GND wiring pattern of externally attached components also does not change.

### (11) Externally attached capacitors

When using ceramic capacitors for externally attached capacitors, determine constants upon taking into account a lowering of the rated capacitance due to DC bias and capacitance change due to factors such as temperature.

### (12) Thermal shutdown circuit (TSD)

When the junction temperature reaches the defined value, the thermal shutdown circuit operates and turns a switch OFF. The thermal shutdown circuit, which is aimed at isolating the LSI from thermal runaway as much as possible, is not aimed at the protection or guarantee of the LSI. Therefore, do not continuously use the LSI with this circuit operating or use the LSI assuming its operation.

### (13) Thermal design

Perform thermal design in which there are adequate margins by taking into account the permissible dissipation (Pd) in actual states of use.

### Notes

- No technical content pages of this document may be reproduced in any form or transmitted by any means without prior permission of ROHM CO.,LTD.
- The contents described herein are subject to change without notice. The specifications for the product described in this document are for reference only. Upon actual use, therefore, please request that specifications to be separately delivered.
- Application circuit diagrams and circuit constants contained herein are shown as examples of standard use and operation. Please pay careful attention to the peripheral conditions when designing circuits and deciding upon circuit constants in the set.
- Any data, including, but not limited to application circuit diagrams information, described herein are intended only as illustrations of such devices and not as the specifications for such devices. ROHM CO.,LTD. disclaims any warranty that any use of such devices shall be free from infringement of any third party's intellectual property rights or other proprietary rights, and further, assumes no liability of whatsoever nature in the event of any such infringement, or arising from or connected with or related to the use of such devices.
- Upon the sale of any such devices, other than for buyer's right to use such devices itself, resell or otherwise dispose of the same, no express or implied right or license to practice or commercially exploit any intellectual property rights or other proprietary rights owned or controlled by
- ROHM CO., LTD. is granted to any such buyer.
- Products listed in this document are no antiradiation design.

The products listed in this document are designed to be used with ordinary electronic equipment or devices (such as audio visual equipment, office-automation equipment, communications devices, electrical appliances and electronic toys).

Should you intend to use these products with equipment or devices which require an extremely high level of reliability and the malfunction of which would directly endanger human life (such as medical instruments, transportation equipment, aerospace machinery, nuclear-reactor controllers, fuel controllers and other safety devices), please be sure to consult with our sales representative in advance.

It is our top priority to supply products with the utmost quality and reliability. However, there is always a chance of failure due to unexpected factors. Therefore, please take into account the derating characteristics and allow for sufficient safety features, such as extra margin, anti-flammability, and fail-safe measures when designing in order to prevent possible accidents that may result in bodily harm or fire caused by component failure. ROHM cannot be held responsible for any damages arising from the use of the products under conditions out of the range of the specifications or due to non-compliance with the NOTES specified in this catalog.

Thank you for your accessing to ROHM product informations.

More detail product informations and catalogs are available, please contact your nearest sales office.

**ROHM** Customer Support System

THE AMERICAS / EUROPE / ASIA / JAPAN

[www.rohm.com](http://www.rohm.com)

Contact us : [webmaster@rohm.co.jp](mailto:webmaster@rohm.co.jp)