

1. Dimensions:

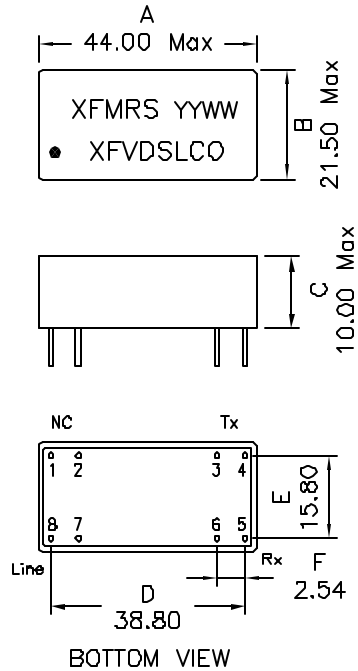

2. Schematic:

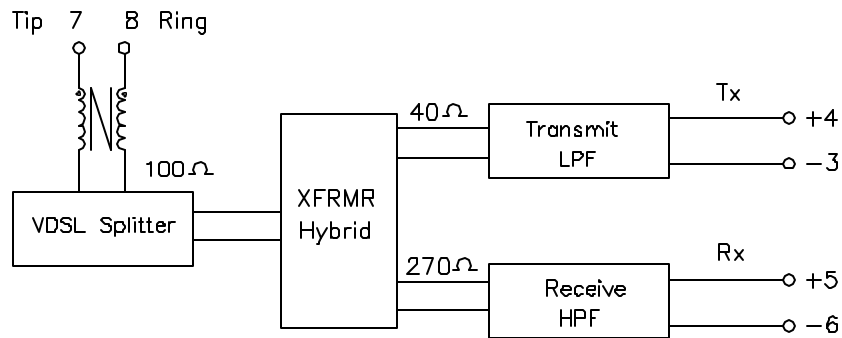

3. Electrical Specifications: @25°C

Description	Passband Frequency	Insertion Loss (Max)	Return Loss (Min)	Stopband Frequency	Attn. (Min)	Impedance
VDSL Splitter/Hybrid	900KHz-7.9MHz	0.8 dB	10 dB	20KHz-150KHz	60 dB	100 Ohms
RX HPF	4.0MHz-7.9MHz	0.8 dB	12 dB	900KHz-3.3MHz	50 dB	270 Ohms
TX LPF	900KHz-3.3MHz	0.8 dB	10 dB	4.0MHz-7.9MHz	15 dB	40 Ohms

Note:

1. Solderability: Leads shall meet MIL-STD-202, Method 208D for solderability.
2. Flammability: UL94V-0,
3. ASTM oxygen index: > 28% ,
4. Temperature rating: 155°C. UL file E151556,
5. Operating Temperature Range: -40°C to +85°C

DOC. REV. A/6

THIS DOCUMENT IS STRICTLY NOT ALLOWED TO BE DUPLICATED WITHOUT AUTHORIZATION

XFMRs Inc	Title: VDSL FILTER/HYBRID SOLUTION	
	UNLESS OTHERWISE SPECIFIED TOLERANCES: .xx ±0.25 Dimensions in MM	
	P/N: XFVDSLCO	REV. A
	DWN. 李小锋	May-09-02
CHK. 廖玉坤	May-09-02	
APP. Isaiah M	May-09-02	

SHT 1 OF 1