

### FEATURES

- $\pm 10$  mV max. initial tolerance (A grade)
- Operating Current  $10\mu\text{A}$  to  $20\text{mA}$
- Low Voltage Reference 1.235
- Max.  $0.6\Omega$  Dynamic Impedance (A grade)
- Low Temperature Coefficient

### APPLICATIONS

- Battery Powered Systems
- Instrumentation
- A/D, D/A Converters
- Temperature measurement
- Current sources
- Pagers

### GENERAL DESCRIPTION

The AMS9491 is a two-terminal micropower band-gap voltage reference diode. It features a very low dynamic impedance and good temperature coefficient, operating over a  $10\mu\text{A}$  to  $20\text{mA}$  current range. On-chip trimming is used to provide tight voltage tolerance. Since the AMS9491 is a band-gap reference, uses only transistors and resistors, low noise and good long-term stability result. Careful design of the AMS9491 has made the device exceptionally tolerant of capacitive loading, making it easy to use in almost any reference application. The wide dynamic operating range allows its use with widely varying supplies with excellent regulation. The extremely low power drain of the AMS9491 makes this reference diode useful for micropower circuitry.

The AMS9491 can be used to make portable meters, regulators or general purpose analog circuitry with battery life approaching shelf life. Further more, the wide operating current allows it to replace older references with a tight tolerance part. The AMS9491 is operating over a  $0^\circ\text{C}$  to  $70^\circ\text{C}$  temperature range and is available in TO-92 and SO-8 packages.

### ORDERING INFORMATION:

TOL.	PACKAGE TYPE		OPERATING TEMPERATURE RANGE
	TO-92	8 LEAD SOIC	
$\pm 10\text{mV}$	AMS9491AN	AMS9491AS	0 to $70^\circ\text{C}$
$\pm 20\text{mV}$	AMS9491BN	AMS9491BS	0 to $70^\circ\text{C}$

### PIN CONNECTIONS

**TO-92  
Plastic Package (N)**

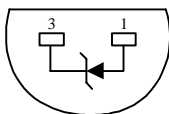

**Bottom View**

**8L SOIC  
SO Package (S)**

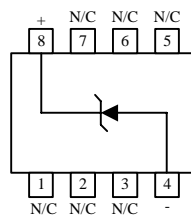

**Top View**

## ABSOLUTE MAXIMUM RATINGS (Note 1)

Reverse Current	30mA	Soldering information (25 sec.)	265°C
Forward Current	10mA		
Operating Temperature Range	0°C to 70°C		
Storage temperature	-55°C to +150°C		

## ELECTRICAL CHARACTERISTICS

Electrical Characteristics at  $I_R = 100 \mu\text{A}$ , and  $T_A = +25^\circ\text{C}$  unless otherwise specified.

Parameter	Conditions	AMS9491A			AMS9491B			Units
		Min	Typ	Max	Min	Typ	Max	
Reverse Breakdown Voltage (Note 4)	$I_R = 100 \mu\text{A}$	<b>1.215</b>	<b>1.235</b>	<b>1.255</b>	<b>1.215</b>	<b>1.235</b>	<b>1.255</b>	V
Reverse Dynamic Impedance (Note 4)	$I_R = 100 \mu\text{A}$ , $f = 20\text{Hz}$		0.2	0.6		0.2	0.6	$\Omega$
Reverse Breakdown Voltage Change with current (Note 4)	$10\mu\text{A} \leq I_R \leq 1\text{mA}$ $1\text{mA} \leq I_R \leq 20\text{mA}$			2.0 20			2.0 20	mV
Min. Operating Current (Note 4)			8	10 <b>20</b>		8	10 <b>20</b>	$\mu\text{A}$
Wide Band Noise (Note 5)	$I_R = 100 \mu\text{A}$ , $10\text{Hz} \leq f \leq 10\text{kHz}$		60			60		$\mu\text{V}$
Temperature Coeff. (Note 6)				<b>50</b>			<b>100</b>	ppm/°C
Long Term Stability (Note 5)	$T_A = 25^\circ\text{C} \pm 1^\circ\text{C}$ $T = 1000 \text{Hr}$		20			20		ppm

**Note 1:** Absolute Maximum Ratings indicate limits beyond which damage to the device may occur. Operating Ratings indicate conditions for which the device is intended to be functional, but do not guarantee specific performance limits. For guaranteed specifications and test conditions, see the Electrical Characteristics. The guaranteed specifications apply only for the test conditions listed.

**Note 2:** Thermal resistance is as follows:

Thermal Resistance	TO-92	SO-8
$\Phi_{JA}$ (junction to ambient)	170°C/W (0.125" leads)	165°C/W

**Note 3:** Parameters identified with **boldface type** apply at temperature extremes. All other numbers apply at  $T_A = T_J = 25^\circ\text{C}$ .

**Note 4:** Guaranteed and 100% production tested.

**Note 5:** Guaranteed but not 100% production tested. These limits are not used to calculate average outgoing quality levels.

**Note 6:** The average temperature coefficient is defined as the maximum deviation of reference voltage at all measured temperatures between the operating  $T_{MAX}$  and  $T_{MIN}$ , divided by  $T_{MAX} - T_{MIN}$ . The measured temperatures are 0°C, 25°C, 70°C.

## TYPICAL APPLICATIONS

**Wide Input Range Reference**

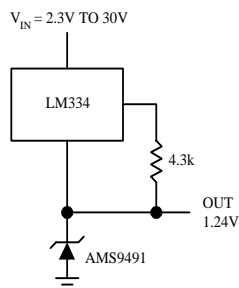

**Micropower Reference from 9V Battery**

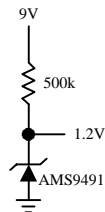

**Reference from 1.5V Battery**

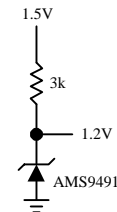

**0°C - 100°C Thermometer**

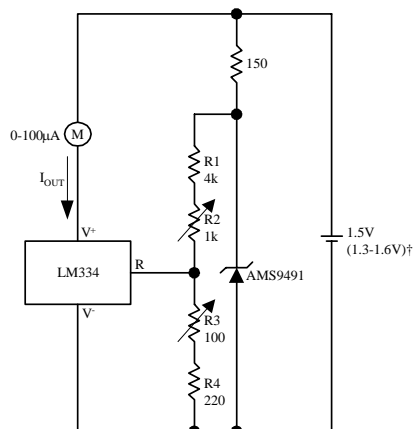

**Lower Power Thermometer**

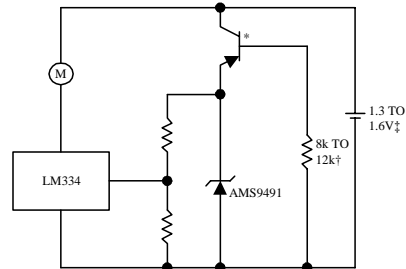

\* 2N3638 or 2N2907 select for inverse  $H_{FE} \cong 5$   
 † Select for operation at 1.3V  
 ‡  $I_Q \cong 600\mu\text{A}$  to  $900\mu\text{A}$

**0°C - 100°C Thermometer**

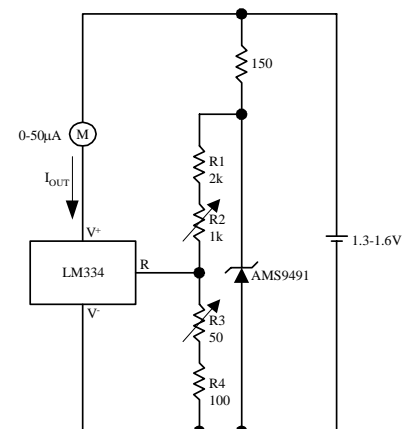

### Calibration

1. Short AMS9491, adjust R3 for  $I_{OUT} = \text{temp}$  at  $1\mu\text{A}/^\circ\text{K}$
2. Remove short, adjust R2 for correct reading in  $^\circ\text{C}$

†  $I_Q$  at 1.3V  $\cong 500\mu\text{A}$   
 $I_Q$  at 1.6V  $\cong 2.4\text{mA}$

### Calibration

1. Short AMS9491, adjust R3 for  $I_{OUT} = \text{temp}$  at  $1.8\mu\text{A}/^\circ\text{K}$
2. Remove short, adjust R2 for correct reading in  $^\circ\text{F}$

## TYPICAL APPLICATIONS (Continued)

### Centigrade Thermometer

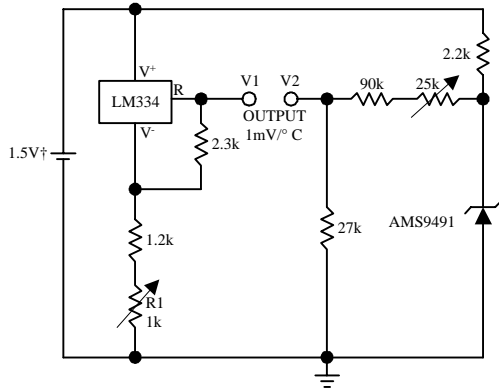

### Micropower\* 10V Reference

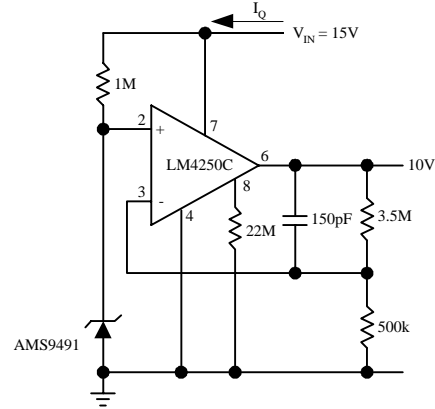

\* $I_Q \cong 20\mu\text{A}$  standby current

### Calibration

1. Adjust R1 so that  $V1 = \text{temp at } 1\text{mV}/^\circ\text{K}$ .
  2. Adjust V2 to 273.2mV.
- †  $I_Q$  for 1.3V to 1.6V battery voltage = 50 $\mu\text{A}$  to 150 $\mu\text{A}$

### Micropower Thermocouple Cold Junction Compensator

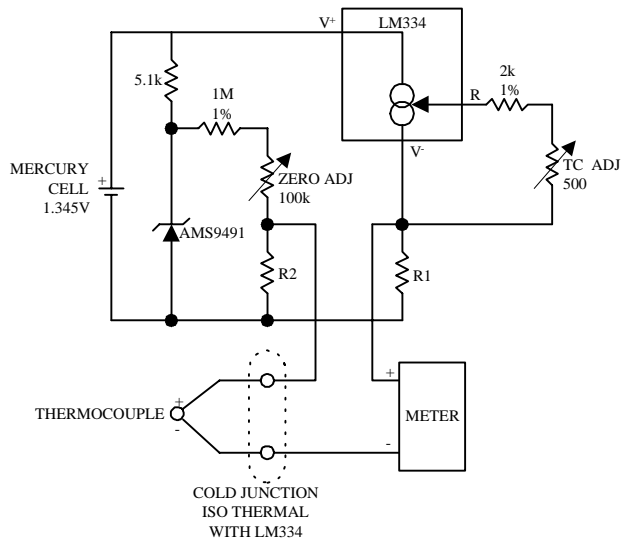

### Adjustment Procedure

1. Adjust TC ADJ pot until voltage across R1 equals Kelvin temperature multiplied by the thermocouple Seebeck coefficient.
2. Adjust ZERO ADJ pot until voltage across R2 equals the thermocouple Seebeck coefficient multiplied by 273.2.

Thermocouple Type	Seebeck Coefficient (mV/°C)	R1 (Ω)	R2 (Ω)	Voltage Across R1 @ 25°C (mV)	Voltage Across R2 (mV)
J	52.3	523	1.24k	15.60	14.32
T	42.8	432	1k	12.77	11.78
K	40.8	408	953Ω	12.17	11.17
S	6.4	63.4	150Ω	1.908	1.766

Typical supply current 50 $\mu\text{A}$

## TYPICAL APPLICATIONS (Continued)

### Precision 1 $\mu$ A to 1mA Current Sources

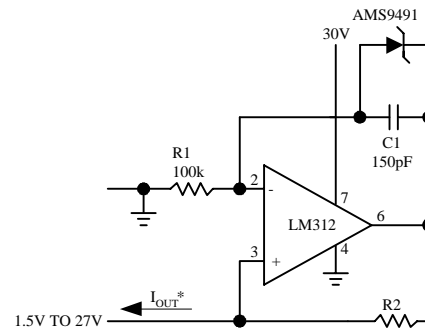
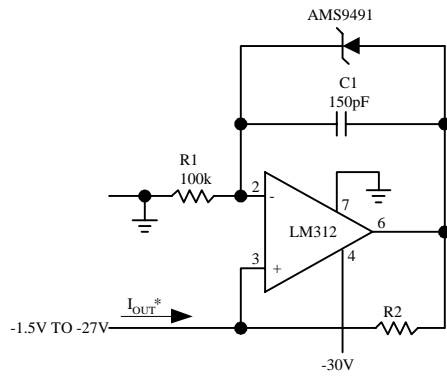

$$*I_{OUT} = 1.23V/R2$$

## TYPICAL PERFORMANCE CHARACTERISTICS

