

M62368GP

3 V Type 8-bit 6ch D/A Converter with Buffer Amplifiers

REJ03D0878-0201

Rev.2.01

Dec 27, 2007

Description

The M62368GP is a CMOS semiconductor IC, containing 6 channels of 8-bit D/A converters. It is operable with a low supply voltage between 2.7 to 3.6 V, and is easy to use due to serial data input, and 3-pin (DI, CLK, LD) connection with microcomputer.

The IC also contains D_O pin terminal, enabling cascade connection, and therefore is suitable for automatic control in combination with a microcomputer.

Features

- Operable with a low voltage between 2.7 to 3.6 V
- 12-bit serial data input (connected via 3 pins: DI, CLK, LD)
- 6 channels of R-2R and segment type high-performance 8-bit D/A converters
- 6 buffer operational amplifiers with full swing of output voltage between V_{CC} and GND
- High oscillation stability against the capacitive load of buffer operational amplifiers

Application

Digital/analog conversion in industrial or home-use electronic equipment.

Automatic control in combination with EEPROM and microcomputer (Substitute for conventional semi-fixed resistor).

Block Diagram

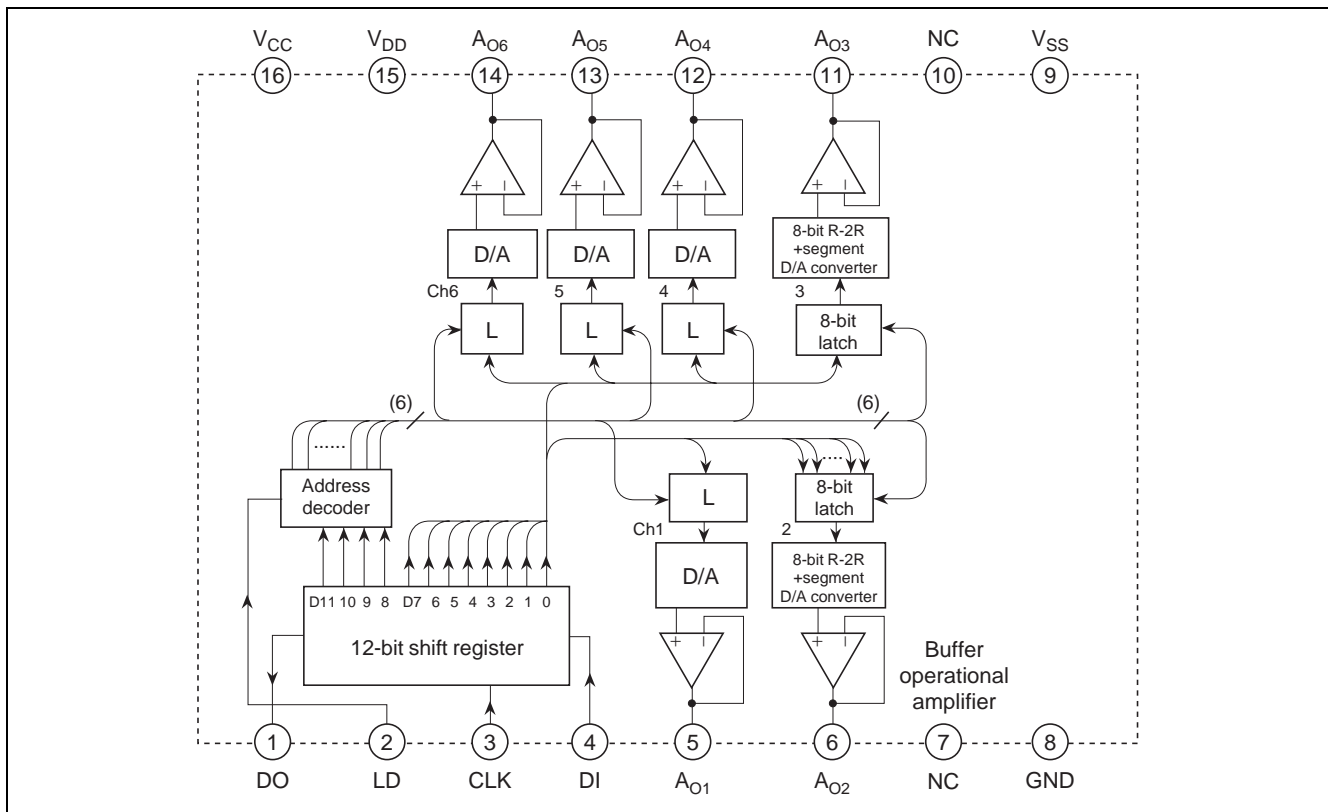

Pin Arrangement

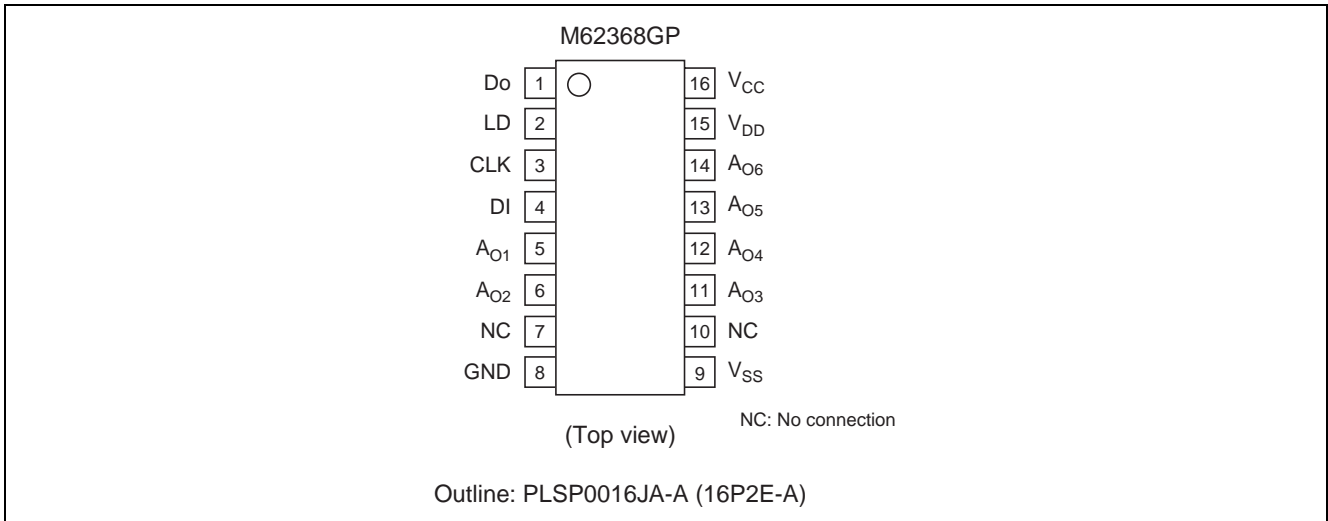

Pin Description

Pin No.	Pin Name	Function
4	DI	Serial data input terminal to input 12-bit long serial data
1	Do	Terminal to output MSB data of 12-bit shift register
3	CLK	Shift clock input terminal. Input signal at DI pin is input to 12-bit shift register at rise of shift clock pulse
2	LD	When H-level signal is input to this terminal, the value stored in 12-bit shift register is loaded in decoder and D/A converter output register.
5	A ₀₁	8-bit D/A converter output terminal
6	A ₀₂	
11	A ₀₃	
12	A ₀₄	
13	A ₀₅	
14	A ₀₆	
16	V _{CC}	Power supply terminal
8	GND	GND terminal
15	V _{DD}	D/A converter upper reference voltage input terminal
9	V _{SS}	D/A converter lower reference voltage input terminal

Block Diagram for Explanation of Terminals

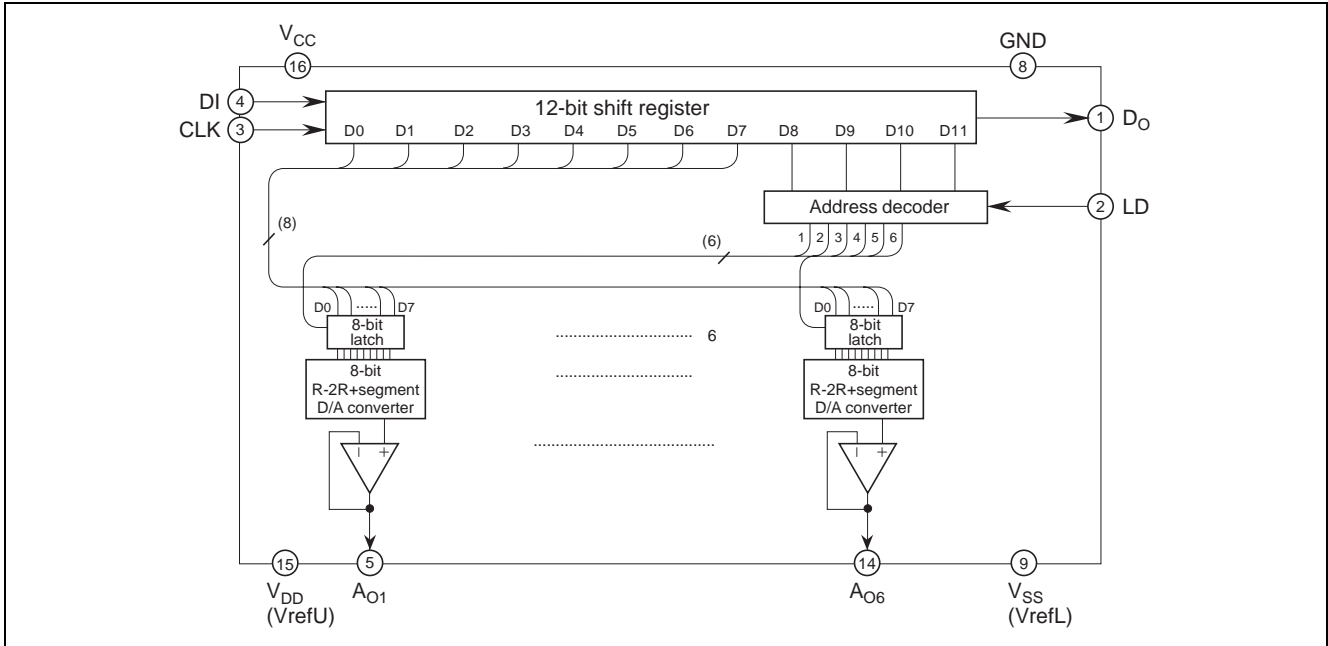

Absolute Maximum Ratings

Item	Symbol	Ratings	Unit
Supply voltage	V _{CC}	-0.3 to +7.0	V
Upper reference voltage of D/A converter	V _{DD}	-0.3 to +7.0	V
Input voltage	V _{IN}	-0.3 to V _{CC} + 0.3	V
Output voltage	V _O	-0.3 to V _{CC} + 0.3	V
Power dissipation	P _d	150	mW
Operating temperature	T _{opr}	-20 to +85	°C
Storage temperature	T _{stg}	-40 to +125	°C

Electrical Characteristics

<Digital Part>

(V_{CC} , $V_{refU} = +3 \text{ V} \pm 10\%$, $V_{CC} \geq V_{refU}$, GND, $V_{refL} = 0 \text{ V}$, $T_a = -20$ to $+85^\circ\text{C}$, unless otherwise noted.)

Item	Symbol	Limits			Unit	Conditions
		Min	Typ	Max		
Supply voltage	V_{CC}	2.7	3.0	3.6	V	
Circuit current	I_{CC}	—	—	3.5	mA	CLK = 1 MHz operation, $V_{CC} = 3 \text{ V}$, $I_{AO} = 0 \mu\text{A}$
Input leak current	I_{ILK}	-10	—	10	μA	$V_{IN} = 0$ to V_{CC}
Input low voltage	V_{IL}	—	—	$0.2 V_{CC}$	V	
Input high voltage	V_{IH}	$0.8 V_{CC}$	—	—	V	
Output low voltage	V_{OL}	—	—	0.4	V	$I_{OL} = 2.5 \text{ mA}$
Output high voltage	V_{OH}	$V_{CC} - 0.4$	—	—	V	$I_{OH} = -400 \mu\text{A}$

<Analog Part>

(V_{CC} , $V_{refU} = +3 \text{ V} \pm 10\%$, $V_{CC} \geq V_{refU}$, $T_a = -20$ to $+85^\circ\text{C}$, unless otherwise noted.)

Item	Symbol	Limits			Unit	Conditions
		Min	Typ	Max		
Current dissipation	I_{refU}	—	1.4	2.5	mA	$V_{refU} = 3 \text{ V}$, $V_{refL} = 0 \text{ V}$ Data condition: at maximum current
D/A converter upper reference voltage range	V_{refU}	$0.7 V_{CC}$	—	V_{CC}	V	Reference voltage cannot always be set to any value in this range, because it is restricted to the buffer amplifier output voltage range.
D/A converter lower reference voltage range	V_{refL}	GND	—	$0.3 V_{CC}$	V	
Buffer amplifier output voltage range	V_{AO}	0.1	—	$V_{CC} - 0.1$	V	$I_{AO} = \pm 500 \mu\text{A}$
		0.2	—	$V_{CC} - 0.2$	V	$I_{AO} = +500 \mu\text{A}$ $-200 \mu\text{A}$
Buffer amplifier output driving range	I_{AO}	-0.3	—	1	mA	Upper saturation voltage = 0.4 V Lower saturation voltage = 0.4 V
Differential nonlinearity error	S_{DL}	-1.0	—	1.0	LSB	$V_{CC} = 2.760 \text{ V}$ $V_{refU} = 2.610 \text{ V}$
Nonlinearity error	S_L	-1.5	—	1.5	LSB	$V_{refL} = 0.050 \text{ V}$ (10 mV/LSB)
Zero code error	S_{ZERO}	-2	—	2	LSB	Without load ($I_{AO} = \pm 0$)
Full scale error	S_{FULL}	-2	—	2	LSB	
Output capacitive load	C_O	—	—	0.1	μF	
Buffer amplifier output impedance	R_O	—	5	—	Ω	

AC Characteristics

(V_{CC} , $V_{refU} = +3\text{ V} \pm 10\%$, $V_{CC} \geq V_{refU}$, GND , $V_{refL} = 0\text{ V}$, $T_a = -20$ to $+85^\circ\text{C}$, unless otherwise noted.)

Item	Symbol	Limits			Unit	Conditions
		Min	Typ	Max		
Clock "L" pulse width	t_{CKL}	200	—	—	ns	
Clock "H" pulse width	t_{CKH}	200	—	—	ns	
Clock rise time	t_{CR}	—	—	200	ns	
Clock fall time	t_{CF}	—	—	200	ns	
Data setup time	t_{DCH}	30	—	—	ns	
Data hold time	t_{CHD}	60	—	—	ns	
LD setup time	t_{CHL}	200	—	—	ns	
LD hold time	t_{LDC}	100	—	—	ns	
LD "H" pulse duration time	t_{LDH}	100	—	—	ns	
Data output delay time	t_{DO}	70	—	350	ns	$C_L = 100\text{ pF}$
D/A output setting time	t_{LDD}	—	—	300	μs	$C_L \geq 100\text{ pF}$, $V_{AO}: 0.1 \leftrightarrow 2.6\text{ V}$ This time until the output becomes the final value of 1/2 LSB

Timing Chart

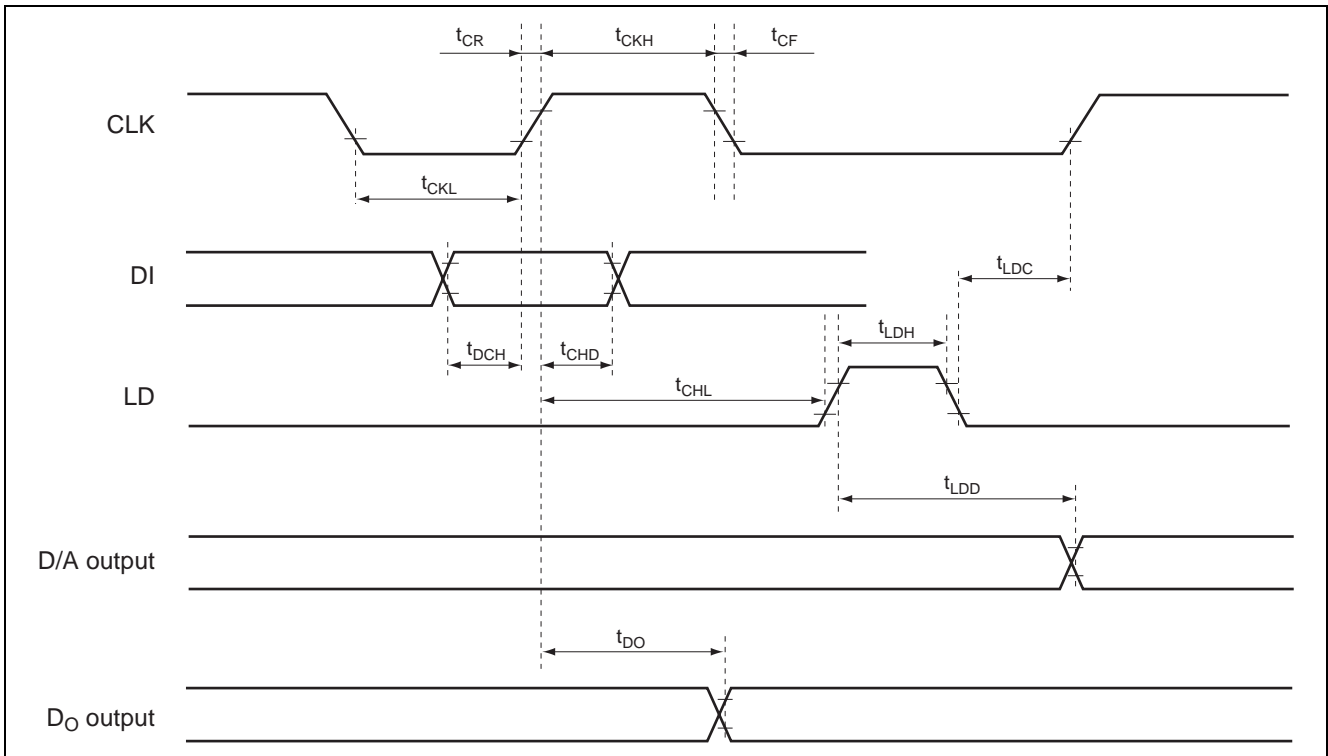

Digital Data Format

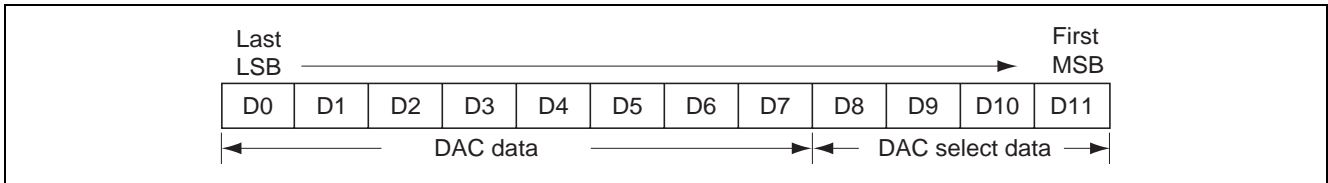

DAC Data

D0	D1	D2	D3	D4	D5	D6	D7	D/A Output
0	0	0	0	0	0	0	0	$(V_{refU} - V_{refL}) / 256 \times 1 + V_{refL}$
1	0	0	0	0	0	0	0	$(V_{refU} - V_{refL}) / 256 \times 2 + V_{refL}$
0	1	0	0	0	0	0	0	$(V_{refU} - V_{refL}) / 256 \times 3 + V_{refL}$
1	1	0	0	0	0	0	0	$(V_{refU} - V_{refL}) / 256 \times 4 + V_{refL}$
:	:	:	:	:	:	:	:	:
0	1	1	1	1	1	1	1	$(V_{refU} - V_{refL}) / 256 \times 255 + V_{refL}$
1	1	1	1	1	1	1	1	V_{refU}

Note: $V_{refU} = V_{DD}$, $V_{refL} = V_{SS}$

DAC Select Data

D8	D9	D10	D11	DAC Selection
0	0	0	0	Don't care
0	0	0	1	A_{O1} selection
0	0	1	0	A_{O2} selection
0	0	1	1	A_{O3} selection
0	1	0	0	A_{O4} selection
0	1	0	1	A_{O5} selection
0	1	1	0	A_{O6} selection
0	1	1	1	Don't care
1	0	0	0	Don't care
1	0	0	1	Don't care
1	0	1	0	Don't care
1	0	1	1	Don't care
1	1	0	0	Don't care
1	1	0	1	Don't care
1	1	1	0	Don't care
1	1	1	1	Don't care

Timing Chart (Model)

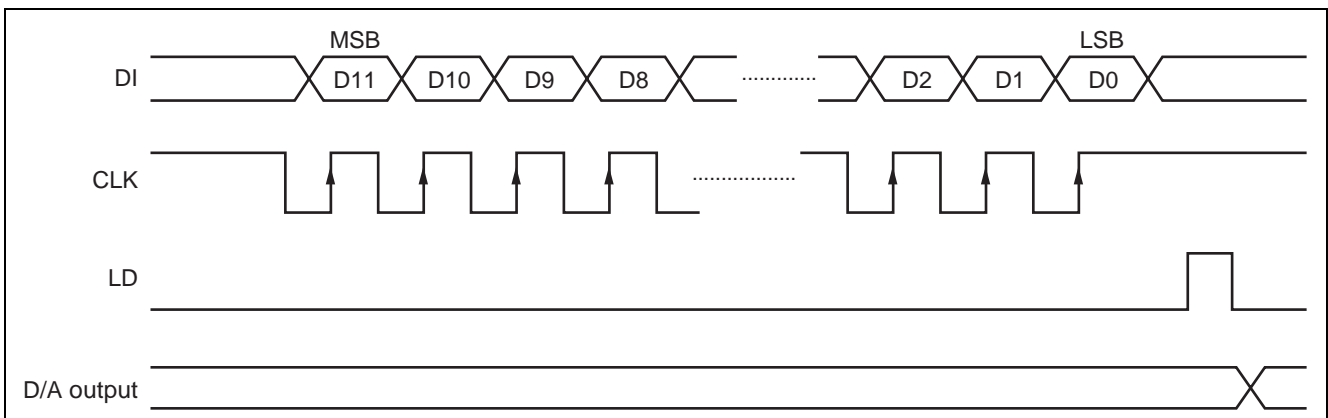

Package Dimensions

JEITA Package Code	RENESAS Code	Previous Code	MASS[Typ.]
P-LSSOP16-4.4x5-0.65	PLSP0016JA-A	16P2E-A	0.06g

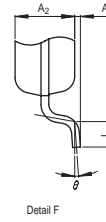
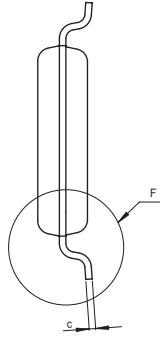
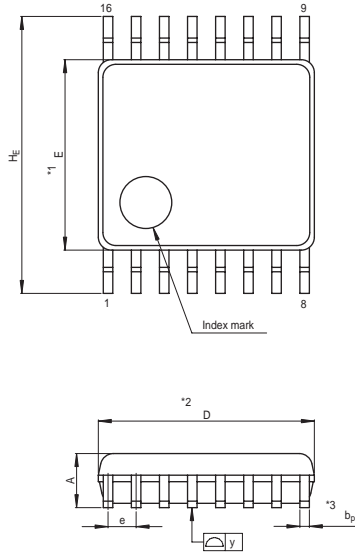

NOTE)
 1. DIMENSIONS **1* AND **2* DO NOT INCLUDE MOLD FLASH.
 2. DIMENSION **3* DOES NOT INCLUDE TRIM OFFSET.

Reference Symbol	Dimension in Millimeters		
	Min	Nom	Max
D	4.9	5.0	5.1
E	4.3	4.4	4.5
A ₂	—	1.15	—
A	—	—	1.45
A ₁	0	0.1	0.2
b _p	0.17	0.22	0.32
c	0.13	0.15	0.2
θ	0°	—	10°
H _E	6.2	6.4	6.6
e	0.53	0.65	0.77
y	—	—	0.10
L	0.3	0.5	0.7

Notes:

1. This document is provided for reference purposes only so that Renesas customers may select the appropriate Renesas products for their use. Renesas neither makes warranties or representations with respect to the accuracy or completeness of the information contained in this document nor grants any license to any intellectual property rights or any other rights of Renesas or any third party with respect to the information in this document.
2. Renesas shall have no liability for damages or infringement of any intellectual property or other rights arising out of the use of any information in this document, including, but not limited to, product data, diagrams, charts, programs, algorithms, and application circuit examples.
3. You should not use the products or the technology described in this document for the purpose of military applications such as the development of weapons of mass destruction or for the purpose of any other military use. When exporting the products or technology described herein, you should follow the applicable export control laws and regulations, and procedures required by such laws and regulations.
4. All information included in this document such as product data, diagrams, charts, programs, algorithms, and application circuit examples, is current as of the date this document is issued. Such information, however, is subject to change without any prior notice. Before purchasing or using any Renesas products listed in this document, please confirm the latest product information with a Renesas sales office. Also, please pay regular and careful attention to additional and different information to be disclosed by Renesas such as that disclosed through our website. (<http://www.renesas.com>)
5. Renesas has used reasonable care in compiling the information included in this document, but Renesas assumes no liability whatsoever for any damages incurred as a result of errors or omissions in the information included in this document.
6. When using or otherwise relying on the information in this document, you should evaluate the information in light of the total system before deciding about the applicability of such information to the intended application. Renesas makes no representations, warranties or guarantees regarding the suitability of its products for any particular application and specifically disclaims any liability arising out of the application and use of the information in this document or Renesas products.
7. With the exception of products specified by Renesas as suitable for automobile applications, Renesas products are not designed, manufactured or tested for applications or otherwise in systems the failure or malfunction of which may cause a direct threat to human life or create a risk of human injury or which require especially high quality and reliability such as safety systems, or equipment or systems for transportation and traffic, healthcare, combustion control, aerospace and aeronautics, nuclear power, or undersea communication transmission. If you are considering the use of our products for such purposes, please contact a Renesas sales office beforehand. Renesas shall have no liability for damages arising out of the uses set forth above.
8. Notwithstanding the preceding paragraph, you should not use Renesas products for the purposes listed below:
 - (1) artificial life support devices or systems
 - (2) surgical implantations
 - (3) healthcare intervention (e.g., excision, administration of medication, etc.)
 - (4) any other purposes that pose a direct threat to human lifeRenesas shall have no liability for damages arising out of the uses set forth in the above and purchasers who elect to use Renesas products in any of the foregoing applications shall indemnify and hold harmless Renesas Technology Corp., its affiliated companies and their officers, directors, and employees against any and all damages arising out of such applications.
9. You should use the products described herein within the range specified by Renesas, especially with respect to the maximum rating, operating supply voltage range, movement power voltage range, heat radiation characteristics, installation and other product characteristics. Renesas shall have no liability for malfunctions or damages arising out of the use of Renesas products beyond such specified ranges.
10. Although Renesas endeavors to improve the quality and reliability of its products, IC products have specific characteristics such as the occurrence of failure at a certain rate and malfunctions under certain use conditions. Please be sure to implement safety measures to guard against the possibility of physical injury, and injury or damage caused by fire in the event of the failure of a Renesas product, such as safety design for hardware and software including but not limited to redundancy, fire control and malfunction prevention, appropriate treatment for aging degradation or any other applicable measures. Among others, since the evaluation of microcomputer software alone is very difficult, please evaluate the safety of the final products or system manufactured by you.
11. In case Renesas products listed in this document are detached from the products to which the Renesas products are attached or affixed, the risk of accident such as swallowing by infants and small children is very high. You should implement safety measures so that Renesas products may not be easily detached from your products. Renesas shall have no liability for damages arising out of such detachment.
12. This document may not be reproduced or duplicated, in any form, in whole or in part, without prior written approval from Renesas.
13. Please contact a Renesas sales office if you have any questions regarding the information contained in this document, Renesas semiconductor products, or if you have any other inquiries.



RENESAS SALES OFFICES

<http://www.renesas.com>

Refer to "<http://www.renesas.com/en/network>" for the latest and detailed information.

Renesas Technology America, Inc.
450 Holger Way, San Jose, CA 95134-1368, U.S.A
Tel: <1> (408) 382-7500, Fax: <1> (408) 382-7501

Renesas Technology Europe Limited
Dukes Meadow, Millboard Road, Bourne End, Buckinghamshire, SL8 5FH, U.K.
Tel: <44> (1628) 585-100, Fax: <44> (1628) 585-900

Renesas Technology (Shanghai) Co., Ltd.
Unit 204, 205, AZIACenter, No.1233 Lujiazui Ring Rd, Pudong District, Shanghai, China 200120
Tel: <86> (21) 5877-1818, Fax: <86> (21) 6887-7858/7898

Renesas Technology Hong Kong Ltd.
7th Floor, North Tower, World Finance Centre, Harbour City, Canton Road, Tsimshatsui, Kowloon, Hong Kong
Tel: <852> 2265-6688, Fax: <852> 2377-3473

Renesas Technology Taiwan Co., Ltd.
10th Floor, No.99, Fushing North Road, Taipei, Taiwan
Tel: <886> (2) 2715-2888, Fax: <886> (2) 3518-3399

Renesas Technology Singapore Pte. Ltd.
1 Harbour Front Avenue, #06-10, Keppel Bay Tower, Singapore 098632
Tel: <65> 6213-0200, Fax: <65> 6278-8001

Renesas Technology Korea Co., Ltd.
Kukje Center Bldg. 18th Fl., 191, 2-ka, Hangang-ro, Yongsan-ku, Seoul 140-702, Korea
Tel: <82> (2) 796-3115, Fax: <82> (2) 796-2145

Renesas Technology Malaysia Sdn. Bhd
Unit 906, Block B, Menara Amcorp, Amcorp Trade Centre, No.18, Jln Persiaran Barat, 46050 Petaling Jaya, Selangor Darul Ehsan, Malaysia
Tel: <603> 7955-9390, Fax: <603> 7955-9510