

Infrared Touch Panels



GENERAL DESCRIPTION

Vishay Dale® TIP products are infrared touch panels designed to fit most flat panel display technologies. The touch panels consist of infrared emitters and detectors, scanning electronics, a microprocessor based controller, a bezel and optical filter assembly and hardware to mount the touch panel assembly to the flat panel display.

These touch panels are ideal for many applications including medical instrumentation, machine or process controllers, point of sale devices, public information displays, banking terminals and military.

Each panel has infrared LED emitters and phototransistors along the X and Y axis, forming a grid of infrared light beams across the face of the display. The first two numbers of the TIP "matrix" number specify the number of X axis (vertical) beams, and the last two numbers specify the number of Y (horizontal) beams. The controller scans the emitter/detector pairs one at a time and determines whether both X and Y beams are blocked, indicating that a finger or stylus is present. (When beams are blocked on only one axis, they are ignored and not reported.) The controller determines the coordinates of the touch point and reports it to the host computer. By interpolating, a "virtual" beam between two physical beams, the number of touch points on each axis is effectively doubled. When an odd number of beams along either axis are blocked, the coordinate of the center physical beam is reported. When an even number of beams are blocked, the coordinate of the virtual beam in the center of the blocked beams is calculated and reported.

Vishay Dale's® TIP touch panels have a unique patented scanning and logic system that make them virtually immune to most lighting environments. The touch controller supports ENTER, EXIT, CONTINUOUS and TRACKING report modes or combinations of these modes. The controller also has a beeper output. Hardware handshaking, software handshaking, baud rates, auto-baud and X, Y coordinate invert features are jumper selected. The user initializes the desired report modes and requests reports when needed.

Several optical filters are standard to provide the most cost effective filter for each application. "Non-standard" filters may be specified as well. The filter increases the contrast ratio of the display and protects the display face and electronics. Dale® can assist in recommending the optimum filter based on years of experience as a display manufacturer. The perimeter of the filter is bonded to the bezel, and a bezel to front panel gasket

FEATURES

- Fast response time < 50 mS
- 69 x 51 switch matrix, over 3500 switches
- Fits Sharp LJ64ZU50/52 directly
- Hardcoated neutral density (gray) CP filter
- Sealed for environmental resistance
- Immune to high or changing ambient light
- RS-232C interface
- Pre-assembled. No assembly or disassembly required to mount display

is included to provide a splash proof seal. Optional PC based software provides simple touch panel integration (see ordering instructions).

TWDriver emulates a mouse in Windows® applications. TBDriver emulates a mouse in DOS applications.

Windows® is a registered trademark of the Microsoft Corporation.

ENVIRONMENTAL SPECIFICATIONS

Operating Temperature: 0°C to + 55°C

Storage Temperature: - 55°C to + 85°C

Relative Humidity: 10% - 90% non-condensing

Ambient Light: 2000 foot candles

ELECTRICAL SPECIFICATIONS

Voltage: + 12 VDC ± 5%

Power Required: 400 mA typical

Beeper Output: Will drive one Schottky TTL load and 90 pF

MATING CONNECTORS

| PIN | DALE® | OTHER |
|--------|-----------|--|
| J1 | 280105-02 | AMP 746288-1 |
| J4 | 280108-06 | MOLEX 22-01-3037 housing 08-50-0114 terminals |
| J5, J6 | 280108-07 | MOLEX 22-01-3027 housing 08-50-0114 terminals |

INTERFACE SPECIFICATIONS

Type: RS-232C.

Data Rate: 300, 1200, 9600 baud and auto baud.

Word Format: 8 bits, no parity, 1 start bit, 1 stop bit.

Touch Points: 69 x 51.

| PIN DESCRIPTION | | | | |
|--|-------------------------------|--------------------------------|--|---------------|
| J1 DATA CONNECTOR | | | J5, J6 POWER CONNECTOR (J6 not present on all models) | |
| TOUCH PANEL CONNECTOR | | HOST CONNECTOR (db - 9) | | PIN |
| | | (db - 25) | | SIGNAL |
| PIN | DESCRIPTION | PIN | PIN | SIGNAL |
| 1 | RD (to touch panel) | 3 | 2 | TD |
| 3 | + 12 VDC (optional) | | | |
| 5 | CTS (to touch panel) | 7 | 4 | RTS |
| 7 | RTS (from touch panel) | 8 | 5 | CTS |
| 9 | Ground | 5 | 7 | GND |
| 2 | Ground | 5 | 7 | GND |
| 4 | + 12 VDC (optional) | | | |
| 6 | Reserved | | | |
| 8 | Reserved | | | |
| 10 | TD (from touch panel) | 2 | 3 | RD |
| J4 AUDIO FEED BACK CONNECTOR (BEEPER) | | | | |
| PIN | SIGNAL | | | |
| 1 | Ground | | | |
| 2 | Beeper Signal (active low) | | | |
| 3 | Beeper Power Output (+ 5 VDC) | | | |
| J6 (when present) is provided to supply power to the display so that only one power cable is needed for the display and touch panel assembly. | | | | |
| W1 JUMPERS | | | | |
| BAUD RATE (Select 1) | | | | |
| Autobaud | | | | |
| 9600 Baud | | | | |
| 1200 Baud | | | | |
| 300 Baud | | | | |
| SOFTWARE HANDSHAKING (A) | | | | |
| NORMAL X (B) | | | | |
| NORMAL Y (C) | | | | |
| (RESERVED) (D) | | | | |

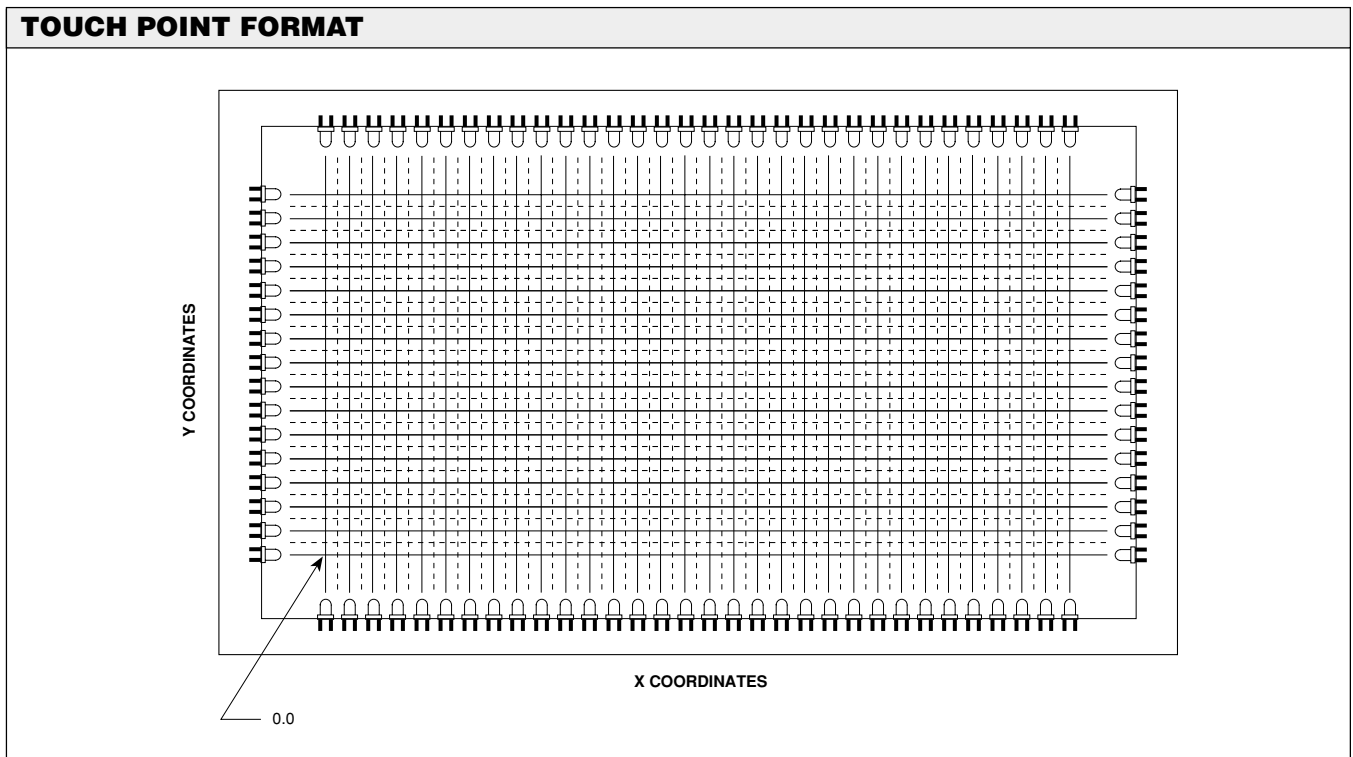

| ORDERING INFORMATION | |
|--|--------------------|
| DESCRIPTION | PART NUMBER |
| Touch Panel | TIP-3526PCS-8 |
| TBDriver | 280879-08 |
| TWDriver | 280879-10 |
| J1 Mating Connector | 280105-02 |
| J4 Mating Connector | 280108-06 |
| If a manual is required for TBDriver or TWDriver, please request at the time of ordering. These will be included as no charge items. | |



| COMMANDS (Code sent to touch panel) | | |
|--|-------------------|---------------------|
| COMMAND | CODE (HEX) | CODE (ASCII) |
| Automatic baud rate selection (ignored when baud rate is jumper selected) | 0D | CR |
| DC1, Ctl Q, XON Software Handshaking | 11 | DC1 |
| DC3, Ctl S, XOFF Software Handshaking | 13 | DC3 |
| *Enable touch panel | 26 | & |
| Disable touch panel (stop scanning) | 27 | , |
| Enable CONTINUOUS/disable TRACKING mode | 24 | \$ |
| *Disable CONTINUOUS and TRACKING mode | 25 | % |
| Enable TRACKING/disable CONTINUOUS mode | 34 | 4 |
| Enable ENTER point mode | 22 | " |
| *Disable ENTER point mode | 23 | # |
| Enable EXIT point mode | 20 | SP |
| *Disable EXIT point mode | 21 | ! |
| Enable automatic report transfer | 29 |) |
| *Disable automatic report transfer (scan but no report) | 2A | * |
| Enable beeper | 2D | - |
| *Disable beeper | 2E | . |
| Failed beam time-out, t = duration (0 to F) (default = 1) | 3At | : |
| *Normal X | 36 | 6 |
| Invert X | 37 | 7 |
| *Normal Y | 38 | 8 |
| Invert Y | 39 | 9 |
| Reset touch panel | 2C | . |
| Request one coordinate report | 2B | + |
| Request failed beam report | 28 | (|
| Request model number | 35 | 5 |
| Request software revision number | 30 | 0 |
| Request touch matrix size | 33 | 3 |
| Sound beeper, tt = duration (00 to FF) | 2Ftt | / |

*Indicates default condition.

COMMAND/RESPONSE DESCRIPTION

Automatic Baud Rate Selection (0D)

For most applications a jumper selected baud rate is recommended. If automatic baud rate selection is required, contact the factory for assistance. (The autobaud command will be ignored if a specific baud rate is jumper selected.)

DC1, Ctl Q, XON Software Handshaking (11)

DC3, Ctl S, XOFF Software Handshaking (13)

RS-232 flow control is provided by these commands. Note: A shunt must be placed on Jumper A (SOFTHAND) to allow software handshaking. Absence of a shunt requires hardware handshaking. (See also ENABLE TOUCH PANEL command.)

***Enable Touch Panel (26)**

Disable Touch Panel (stop scanning) (27)

The touch panel must be enabled for normal operation. When the touch panel is disabled, commands are processed as they are received, allowing changes in modes of operation, but discarding any report operations.

This differs from XON/XOFF software handshaking. When the touch panel receives an XOFF character (13), commands are executed until the touch panel requires transmission of a report, then all commands received are buffered and are not executed until an XON character is received. If the buffer becomes full, the touch panel sends XOFF.

Enable CONTINUOUS/disable TRACKING mode (24)

***Disable CONTINUOUS/disable TRACKING mode (25)**

This coordinate reporting mode will continuously report the coordinates of a stylus that remains in the touch panel. This mode can be used individually or in combination with ENTER point, or EXIT modes. The following report format is used. If more than one stylus enters the touch panel, a non-contiguous report will be generated.

41 = start of coordinate report

xx yy = binary X and Y, > = 0, X, Y = FE if non-contiguous



Enable ENTER point mode (22)

***Disable ENTER point mode (23)**

This coordinate reporting mode will report the coordinates of the point where a stylus is entered into the touch panel. This mode

can be used individually or in combination with EXIT point, CONTINUOUS or TRACKING modes. The following report format

is used. If more than one stylus enters the touch panel, a non-contiguous report will be generated.

- 42 = start of enter report
- xx yy = binary X and Y, > = 0, X, Y = FE if non-contiguous

Enable EXIT point mode (20)

***Disable EXIT point mode (21)**

This coordinate reporting mode will report the coordinate of the point where a stylus is removed from the touch panel. This mode can be used individually or in combination with ENTER point, CONTINUOUS or TRACKING modes. The following report format

is used. If more than one stylus enters the touch panel, a non-contiguous report will be generated.

- 43 = start of exit report
- xx yy = binary X and Y, > = 0, X, Y = FE in non-contiguous

Enable TRACKING/disable CONTINUOUS mode (34)

This coordinate reporting mode will report the coordinates of a stylus that remains in the touch panel, but only as the stylus changes locations. This mode can be used individually or in combination with ENTER point or EXIT modes. The following report format is used.

If more than one stylus enters the touch panel, a non-contiguous report will be generated.

- 4E = start of coordinates report
- xx yy = binary X and Y, > = 0, X, Y = FE if non-contiguous

| RESPONSE (Code received from touch panel) | | |
|--|-------------------|---------------------|
| RESPONSE | CODE (HEX) | CODE (ASCII) |
| Successful baud rate selection (autobaud only) | 40 | @ |
| DC1, Ctl Q, XON Software Handshaking | 11 | DC1 |
| DC3, Ctl S, XOFF Software Handshaking | 13 | DC3 |
| CONTINUOUS touch coordinates, X, Y - binary X and Y, > = 0 - X, Y = FE if non-contiguous | 41 xx yy | A |
| ENTER touch coordinate, X, Y - binary X and Y, > = 0 - X, Y = FE if non-contiguous | 42 xx yy | B |
| EXIT touch coordinates, X, Y - binary X and Y, > = 0 - X, Y = FE if non-contiguous | 43 xx yy | C |
| TRACKING touch coordinates, X, Y - binary X and Y, > = 0 - X, Y = FE if non-contiguous | 4E xx yy | N |
| No coordinate report available | 48 | H |
| Failed beams, bad photo pairs, end | 47 aa-nn FF | G |
| RS-232 error (overrun or framing) | 45 | E |
| Model Number, string, end - aaaa = variable length ASCII string | 50 aaaa FF | P |
| Software revision number, string, end - aaa = variable length ASCII string | 4C aaa FF | L |
| Matrix size, max X + 1, max Y + 1 | 4D xx yy | M |
| Buffer overflow error | 4F | O |

COMMAND/RESPONSE DESCRIPTION (Continued)**Enable automatic reporting (29)*****Disable automatic reporting (scan but no report) (2A)
Request one coordinate report (2B)**

When AUTOMATIC REPORTING is enabled, coordinate reports are reported to the host as soon as they become available. After issuing the ENABLE AUTOMATIC REPORTING command, there may be a report in the internal buffer which is not current. If a sufficient amount of time has passed to allow this condition, the first coordinate report returned should be ignored.

When AUTOMATIC REPORTING is disabled, no coordinate reports are reported unless requested with REQUEST ONE COORDINATE REPORT. If a stylus is entered into the touch panel after AUTOMATIC REPORTING is disabled, a coordinate report will be generated and saved in an internal buffer (depending upon coordinate reporting modes in effect) but will not be transmitted until a REQUEST ONE COORDINATE REPORT command is received.

If no coordinate report is available in the internal buffer, the touch panel will return a code 48 and continue to scan until a stylus is detected. However, no coordinate report will be reported until AUTOMATIC REPORTING is enabled or the report is requested with REQUEST ONE COORDINATE REPORT.

Coordinate reports are reported with the following format:

Report Type = 41, 42, 43 or 4E

xx yy = binary X and Y, > = 0, X, Y = FE if non-contiguous

Enable beeper (2D)***Disable beeper (2E)**

Enabling the beeper sends a logic 0 (active state) to pin 2 of J4 depending on which of the coordinate reporting modes are enabled. If the ENTER mode is enabled, a pulse is sent for every entry point. If the EXIT mode is enabled, a pulse is sent for every exit point. If both modes are enabled, a pulse is sent for every entry and exit point. CONTINUOUS and TRACKING modes have no beeper outputs.

Sound beeper, tt = duration (00 to FF) (2Ftt)

This command sends a logic 0 (active state) to pin 2 of J4. The duration of the beep can be controlled in 10 msec increments from 0 msec (00) to 2.55 sec (FF). Note: 2C may not be used as an argument as it will cause a reset.

*Normal X (36)

Invert X (37)

*Normal Y (38)

Invert Y (39)

The standard configuration for the touch panel places the XY origin at the lower left corner, consistent with the Cartesian coordinate system. Upon issuing the INVERT Y command, the origin becomes the upper left corner, consistent with the video industry standard. These commands allow the user to move the origin to any corner to accommodate different standards or third party mechanical packages which may have the touch panel rotated 180 degrees on the display. To cancel an INVERT X or INVERT Y command, a NORMAL X or NORMAL Y command must be executed.

These commands may also be implemented with jumpers. Placing a shunt on Jumper B (NOR X) causes X data to be normal (default) and removing the shunt causes inverted X

data. Similarly, placing a shunt on Jumper C (NOR Y) causes Y data to be normal (default) or removal causes inverted Y data. The jumper selected options may be overridden with the software commands.

Failed beam time-out (3A t)

If any IR beam is broken for an extended time due to blockage of the beam or failed optical components, the touch panel will ignore that beam after a predetermined number of scans. (This is to prevent failed beams from interfering with touch sensing.) The actual failed beam detection time depends on the modes of operation and the size of the touch matrix. When using the CONTINUOUS mode with AUTOMATIC REPORTING enabled, the time is typically 25 - 30 seconds. If the application requires longer touch times, then the time may be extended using the FAILED BEAM TIME-OUT command. The command accepts arguments from 1 to F.

Request failed beam report (28)

This command returns the address of any infrared diode/phototransistor pair that are blocked (as when a stylus is in the panel) or have several failed scans. (The time period can be extended by using the FAILED BEAM TIME-OUT command.)

The report uses the following format:

47 = start of failed beam report

aa - nn = physical address of failed LED/

Phototransistor pair

FF = end of report

Reset touch panel (2C)

After issuing the RESET command, the touch panel is returned to its power up condition and all operating modes are returned to their default state and the buffer cleared. If autobaud is being used the correct baud rate must again be established.

Request software revision number (30)**Request touch matrix size (33)****Request model number (35)**

These commands are provided for configuration control and diagnostic purposes.

RS-232 framing or overrun error (45)

An RS-232 error indicates communication problems.

Buffer over flow error (4F)

Buffer overflow occurs when the input command buffer is exceeded to lack of handshaking.

INITIALIZATION

Initialization is performed by the host computer and must be done each time the touch panel is powered up or the RESET TOUCH PANEL command is issued. The process begins with baud rate selection (if not jumper selected). The remainder of the initialization process requires setting the desired coordinate reporting modes, enabling or disabling AUTOMATIC REPORTING, enabling or disabling the beeper, and enabling or disabling the touch panel. Default settings are shown in the COMMANDS table.

When touch coordinate information is required by the host computer, the touch panel must be enabled. The flow of touch coordinates from the touch panel to the host computer can be controlled by enabling or disabling AUTOMATIC REPORTING. With AUTOMATIC REPORTING enabled, coordinate reports are sent to the host as soon as they become available. If the host computer is performing a task which does not require touch coordinate information, AUTOMATIC REPORTING may be disabled.

INITIALIZATION/OPERATION - EXAMPLE

In the following example the touch panel is initialized to report coordinates only when a stylus is entered into the touch panel.

The touch panel is enabled by default, and coordinate reporting is not desired unless requested, so AUTOMATIC REPORTING is left disabled by default. It is assumed that the baud rate has been jumper selected.

As a result the touch panel must be continuously polled with REQUEST ONE COORDINATE REPORT (2B) to determine if an enter point coordinate report is available. When a report is available, it will be sent to the host. If no report is available, the touch panel will send code 48 (hex) to the host.

| HOST | TOUCH PANEL | ACTION |
|---------|-----------------|--|
| Send 22 | — | Enables ENTER point mode |
| Send 2B | — | Request report |
| — | Send 48 | No report is available |
| Send 2B | — | Request report |
| — | Send 42, 1D, 12 | A stylus entered the touch panel. The coordinates are X29 and Y18 (decimal) (See Touch Point Format) |
| Send 2B | — | Request report |
| — | Send 48 | No report is available |

MOUNTING

The touch panel and display assembly should be mounted in accordance with mounting instructions specified herein, and as separately specified by the display manufacturer. The vibration and shock specifications only apply to the complete assembly when properly mounted in a rigid front panel.

CLEANING

The bezel is manufactured from polycarbonate which is compatible with most cleaning agents such as alcohol, freon, window cleaners and soap and water. Solvent type cleaning agents should only be used for wiping and short term immersion. Filters are made from polyester polycarbonate or acrylic and also should withstand the above cleaning agents. Care must be taken to avoid scratching the bezel or filter by cleaning with abrasive or coarse cloths. While scratches normally won't affect the function of the touch panel, they will degrade the appearance of the end product and make the display difficult to read.

ELECTROSTATIC CAUTION

Vishay Dale® TIP touch panels use electrostatic sensitive components. These assemblies should be unpacked and handled in an ESD controlled area only. When shipping use packing materials designed for protection of electrostatic sensitive components.

WARRANTY

Vishay Dale® warrants that TIP infrared touch panels will be free from defects in materials and workmanship, and that they will function substantially to these specifications. The TIP touch panels are warranted for one year from shipment from Vishay Dale®. Cosmetic defects (bezel and filter scratches and blemishes) are not warranted unless they are present when the product is first delivered from Vishay Dale Electronics, Inc. Bezel/filter assemblies with cosmetic defects must be returned within 30 days of delivery.

The purchaser must return the defective or nonconforming goods to Vishay Dale® not later than 30 days after Vishay Dale's® issuance of an RMA number. No goods are to be returned without issuance of an RMA number. For a RMA number, contact the Vishay Dale's® customer service department with the model number(s) and original purchase order number(s). When returning goods for repair, please include a brief description of the problem, and mark the outside of the shipping container with the RMA number. The Buyer shall prepay transportation charges, and Vishay Dale® shall pay for the return of the goods to the buyer.

The warranty does not apply in cases of improper or inadequate installation or maintenance by the Buyer, unauthorized modification of the product, operation of the product outside their environmental specifications, neglect or abuse of the product. This warranty is not the full warranty, and should not be interpreted as a substitute for the full warranty.

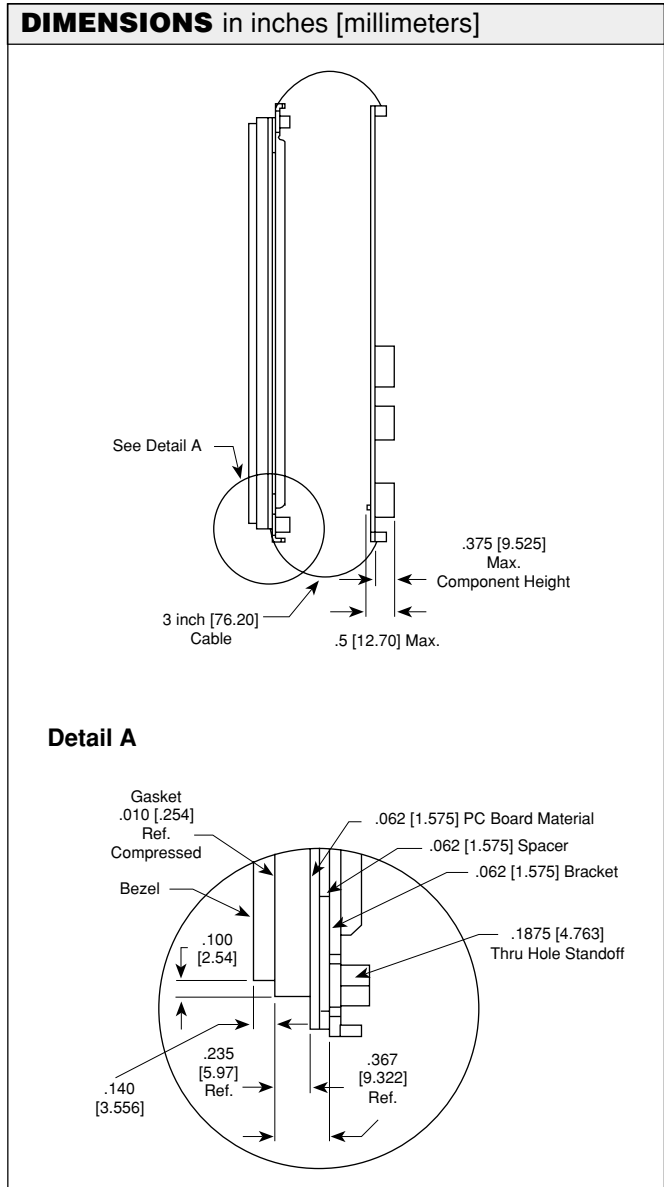

DIMENSIONS in inches [millimeters]

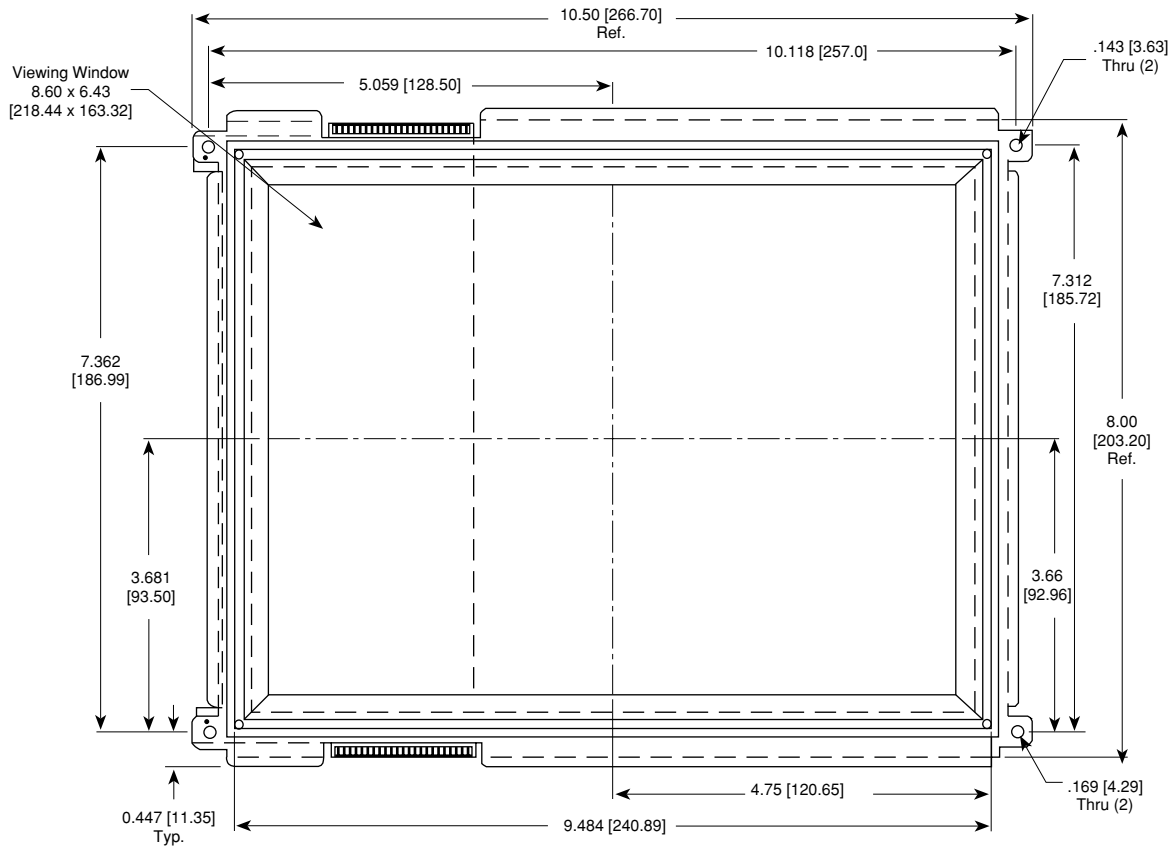

Recommended Panel Cutout 7.332 [186.23]

Recommended Panel Cutout 9.504 [241.40]

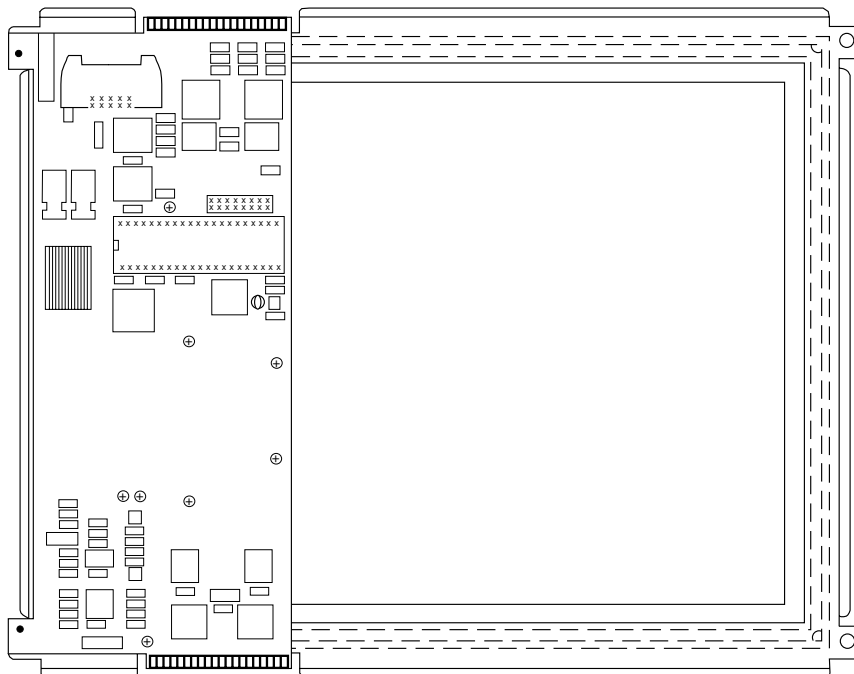

DIMENSIONS in inches [milimeters]

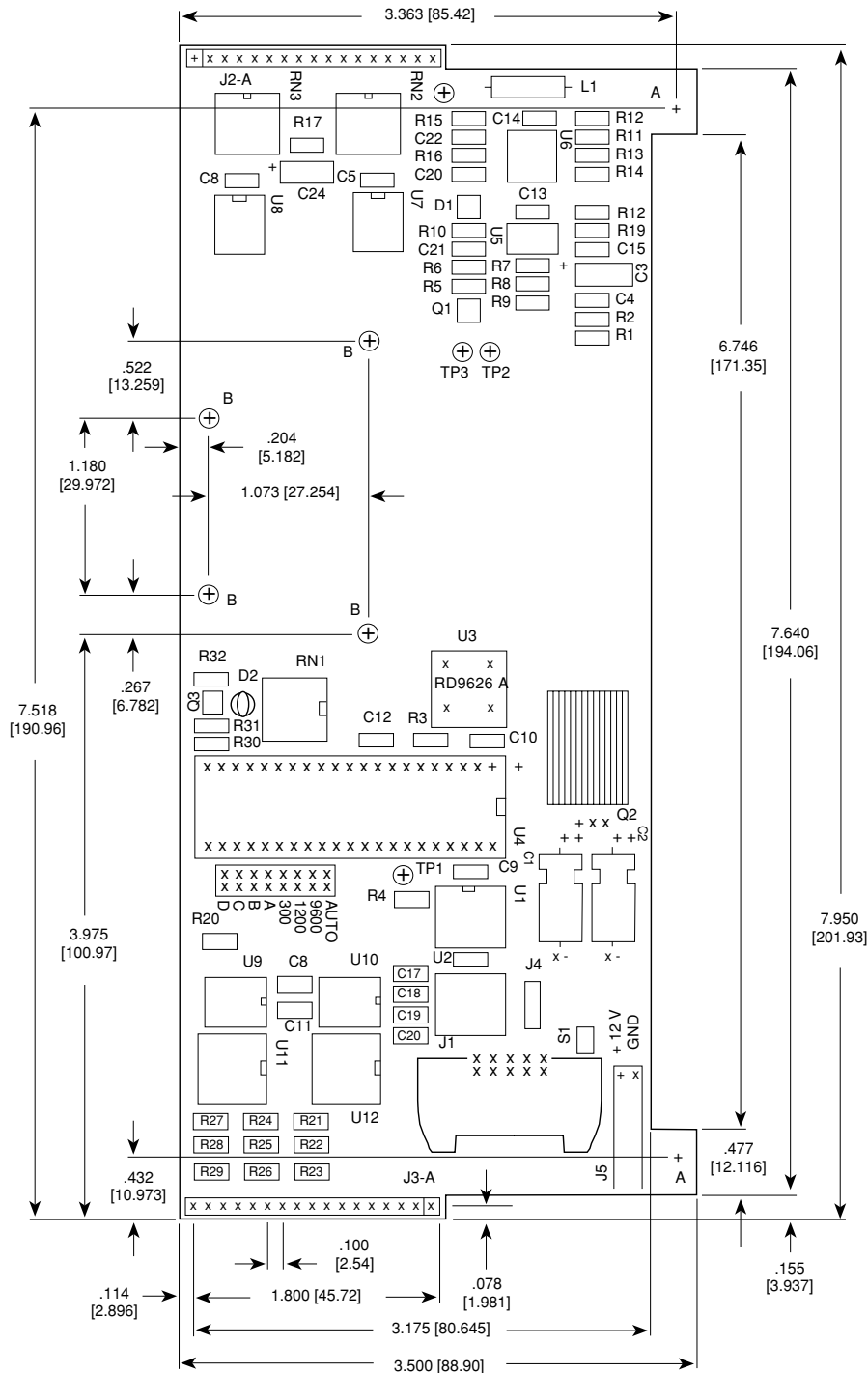

| IDENTIFIER | HOLE SIZE |
|------------|--------------|
| A | .148 [3.759] |
| B | .129 [3.277] |

Vishay Dale Electronics, Inc. believes that the information described in this publication is accurate and reliable, and much care has been taken in its preparation. However, no responsibility, financial or otherwise is accepted for any consequences arising out of the use of this information. This information is subject to change without notice.



Disclaimer

All product specifications and data are subject to change without notice.

Vishay Intertechnology, Inc., its affiliates, agents, and employees, and all persons acting on its or their behalf (collectively, "Vishay"), disclaim any and all liability for any errors, inaccuracies or incompleteness contained herein or in any other disclosure relating to any product.

Vishay disclaims any and all liability arising out of the use or application of any product described herein or of any information provided herein to the maximum extent permitted by law. The product specifications do not expand or otherwise modify Vishay's terms and conditions of purchase, including but not limited to the warranty expressed therein, which apply to these products.

No license, express or implied, by estoppel or otherwise, to any intellectual property rights is granted by this document or by any conduct of Vishay.

The products shown herein are not designed for use in medical, life-saving, or life-sustaining applications unless otherwise expressly indicated. Customers using or selling Vishay products not expressly indicated for use in such applications do so entirely at their own risk and agree to fully indemnify Vishay for any damages arising or resulting from such use or sale. Please contact authorized Vishay personnel to obtain written terms and conditions regarding products designed for such applications.

Product names and markings noted herein may be trademarks of their respective owners.