



# Technical Data Sheet

## Top View LEDs

### 67-11/W1C-GP2R1B2Z/2T

#### Features

- Fluorescence Type
- High Luminous Intensity
- High Efficiency
- ESD protection
- Pb-free.
- The product itself will remain within RoHS compliant version.



#### Descriptions

The white LED which was fabricated using a blue LED and a phosphor, and the phosphor is excited by blue light and emits yellow fluorescence. The mixture of blue light and yellow light results in a white emission.

#### Applications

- OA Equipment
- Backlighting of Full Color LCD
- Automotive Equipment
- Replacement of Conventional Light Bulbs and Fluorescent Lamps

#### Device Selection Guide

Chip	Emitted Color	Resin Color
Material		
InGaN	White	Water Clear

**67-11/W1C-GP2R1B2Z/2T**

**Package Dimensions**

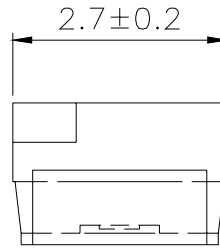
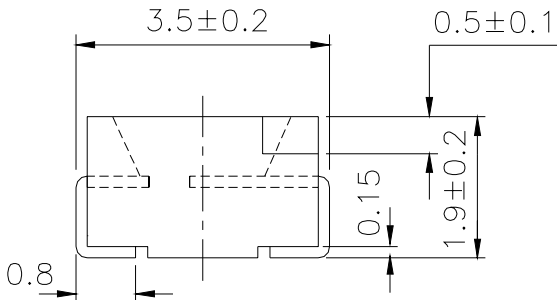
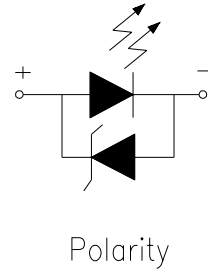
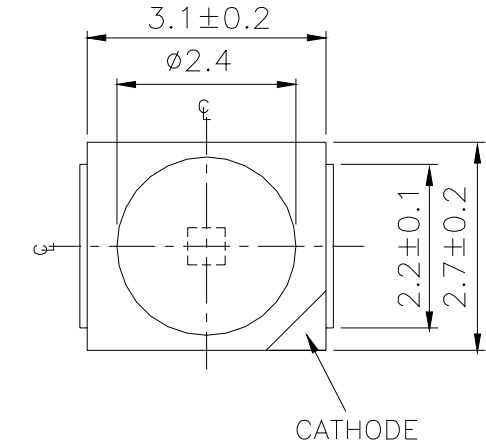

For reflow soldering (Proposal)

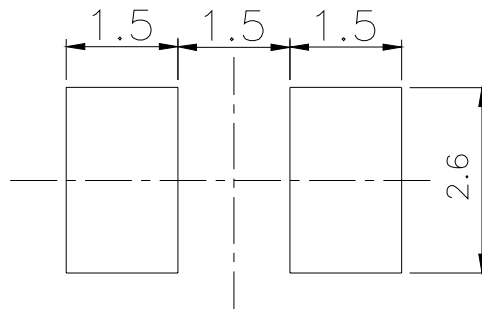
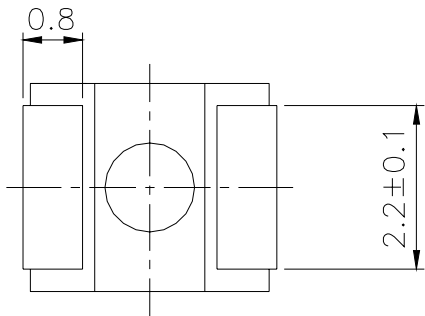

**Note:** The tolerances unless mentioned is  $\pm 0.1$ mm ,Unit = mm

**67-11/W1C-GP2R1B2Z/2T**
**Absolute Maximum Ratings (Ta=25 )**

Parameter	Symbol	Rating	Unit
Reverse Voltage	V <sub>R</sub>	5	V
Forward Current	I <sub>F</sub>	25	mA
Peak Forward Current (Duty 1/10 @1KHz)	I <sub>FP</sub>	100	mA
Power Dissipation	P <sub>d</sub>	110	mW
Operating Temperature	T <sub>opr</sub>	-40 ~ +85	
Storage Temperature	T <sub>stg</sub>	-40 ~ +90	
Electrostatic Discharge(HBM)	ESD	2000	V
Soldering Temperature	T <sub>sol</sub>	Reflow Soldering : 260 for 10 sec. Hand Soldering : 350 for 3 sec.	

**Electro-Optical Characteristics (Ta=25 )**

Parameter	Symbol	Min.	Typ.	Max.	Units	Condition
Luminous Intensity	I <sub>v</sub>	140	-----	285	mcd	I <sub>F</sub> =10mA
Forward Voltage	V <sub>F</sub>	2.80	-----	3.60	V	I <sub>F</sub> =10mA
Viewing Angle	2 1/2	-----	120	-----	deg	I <sub>F</sub> =10mA

**Notes:**
**1.Tolerance of Luminous Intensity ±11%**
**2.Tolerance of Forward Voltage ±0.1V**

**67-11/W1C-GP2R1B2Z/2T****Bin Range Of Luminous Intensity**

Bin Code	Min.	Max.	Unit	Condition
R2	140	180	mcd	IF=10mA
S1	180	225		
S2	225	285		

**Bin Range Of Forward Voltage**

Group	Bin Code	Min.	Max.	Unit	Condition
G	35	2.80	2.90	V	IF=10mA
	36	2.90	3.00		
	37	3.00	3.10		
	38	3.10	3.20		
	39	3.20	3.30		
	40	3.30	3.40		
	41	3.40	3.50		
	42	3.50	3.60		

**Notes:**

- 1.Tolerance of Luminous Intensity  $\pm 11\%$**
- 2.Tolerance of Forward Voltage  $\pm 0.1V$**

**67-11/W1C-GP2R1B2Z/2T**

Color Rank		(If=10mA)	
Group	Bin Code	CIE-x	CIE-y
<b>G</b>	<b>B5</b>	0.296	0.276
		0.287	0.295
		0.307	0.315
		0.311	0.294
	<b>B6</b>	0.311	0.294
		0.307	0.315
		0.330	0.339
		0.330	0.318

**\*The C.I.E. 1931 chromaticity diagram ( Tolerance  $\pm 0.01$ )**

**CIE Chromaticity Diagram**

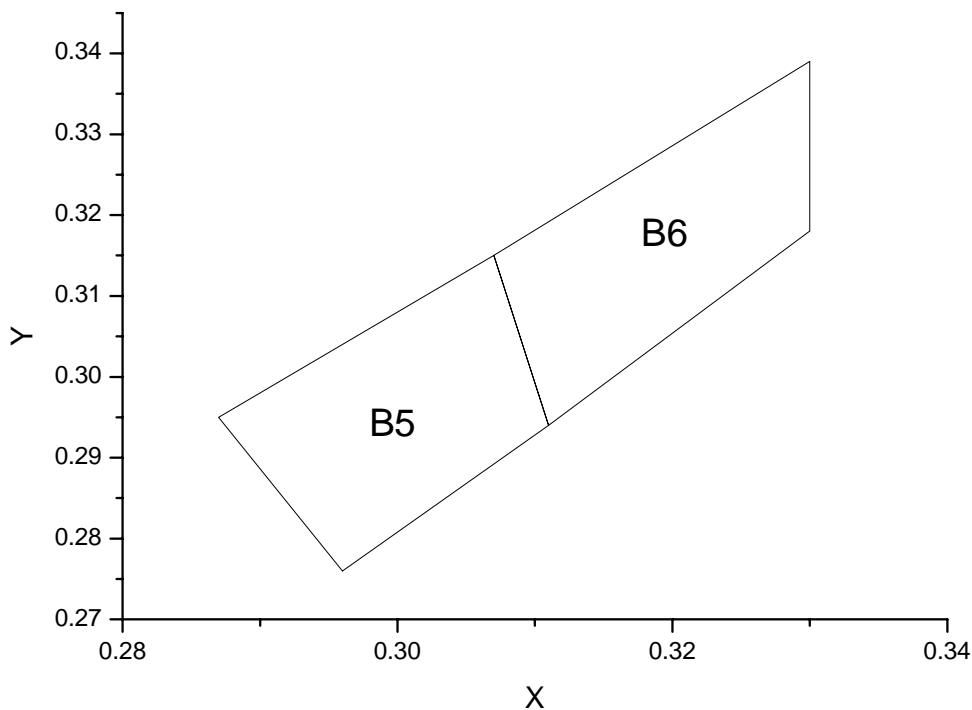

**67-11/W1C-GP2R1B2Z/2T**

**Typical Electro-Optical Characteristics Curves**

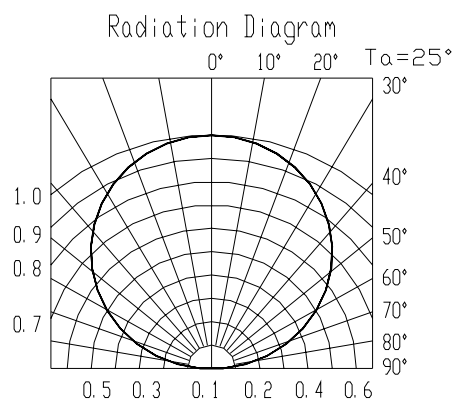
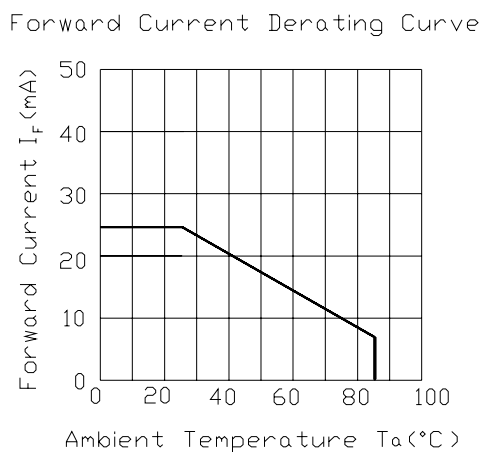
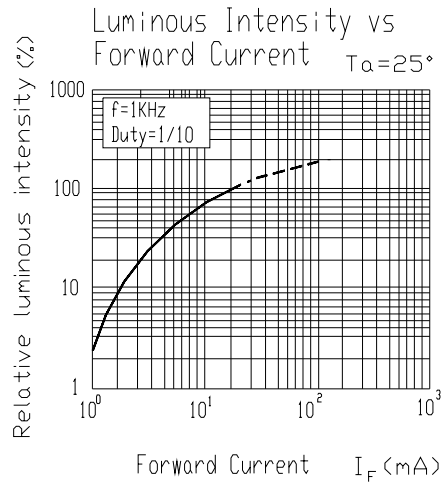
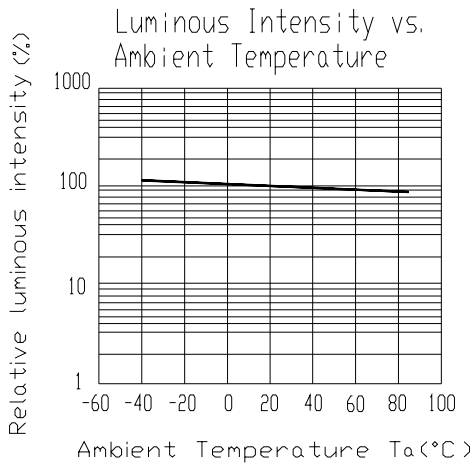
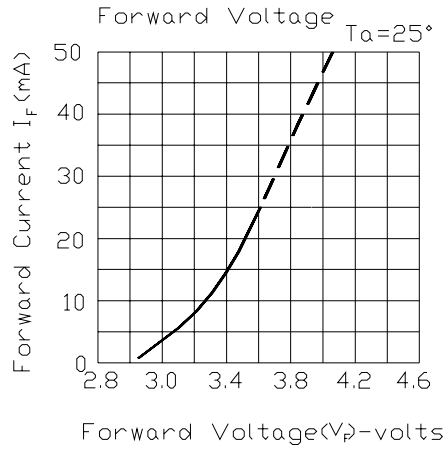
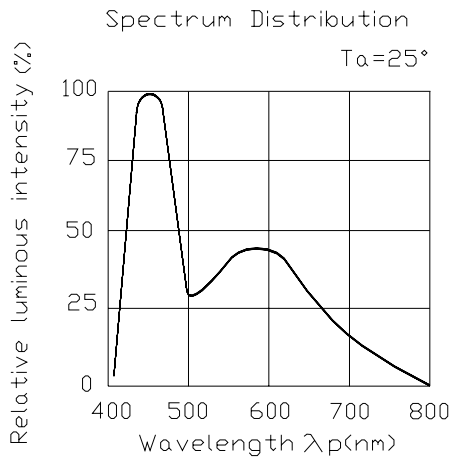



**67-11/W1C-GP2R1B2Z/2T**

**Label explanation**

**CAT: Luminous Intensity Rank**

**HUE: Chromaticity Coordinates**

**REF: Forward Voltage Rank**

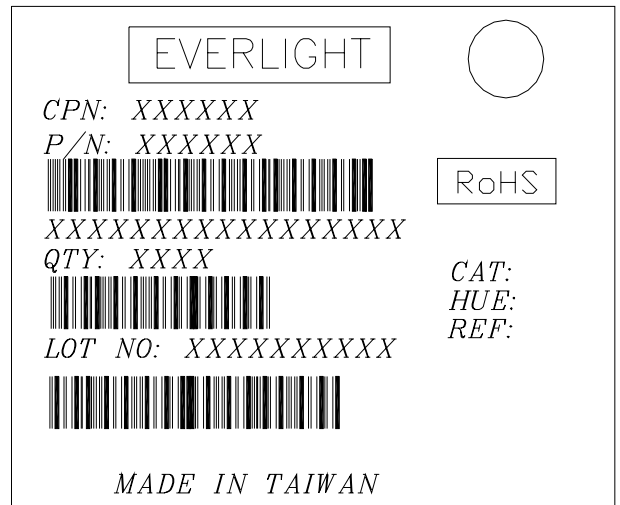

**Reel Dimensions**

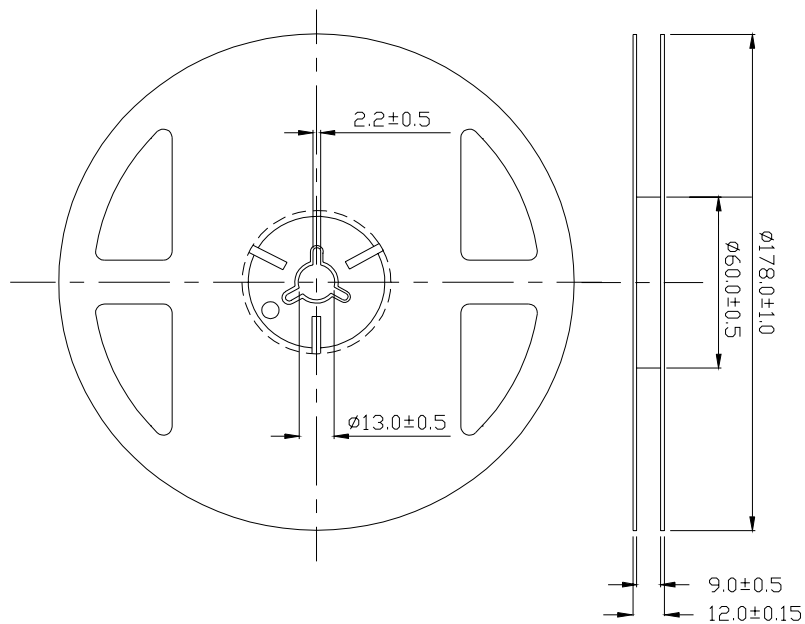

**Note:** The tolerances unless mentioned is ±0.1mm ,Unit = mm

**67-11/W1C-GP2R1B2Z/2T**

**Carrier Tape Dimensions: Loaded quantity 2000 PCS per reel.**

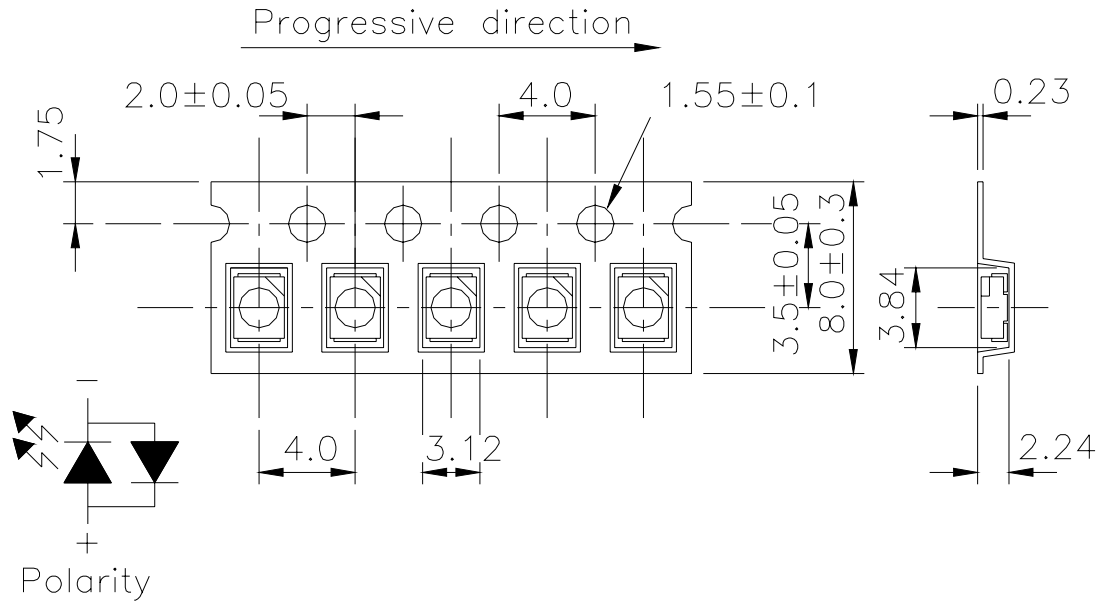

**Note:** The tolerances unless mentioned is  $\pm 0.1$ mm ,Unit = mm

**Moisture Resistant Packaging**

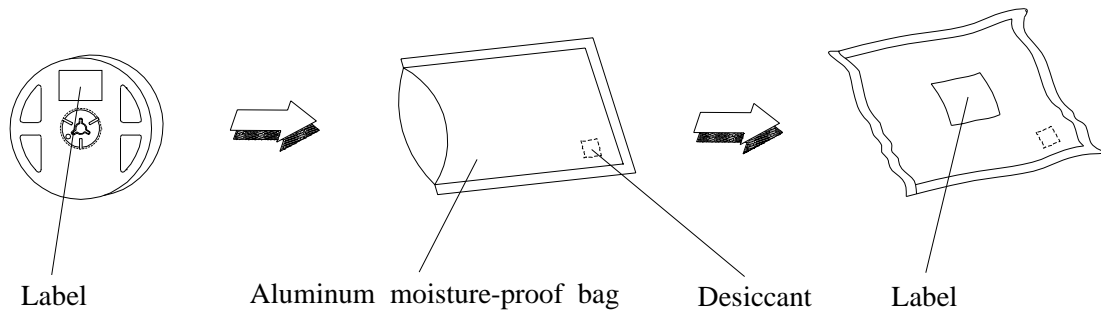



**67-11/W1C-GP2R1B2Z/2T**
**Reliability Test Items And Conditions**

The reliability of products shall be satisfied with items listed below.

Confidence level : 90%

LTPD : 10%

No.	Items	Test Condition	Test Hours/Cycles	Sample Size	Ac/Re
1	Reflow Soldering	Temp. : 260 ±5 Min. 5sec.	6 min	22 PCS.	0/1
2	Temperature Cycle	H : +100 15min 5 min L : -40 15min	300 Cycles	22 PCS.	0/1
3	Thermal Shock	H : +100 5min 10 sec L : -10 5min	300 Cycles	22 PCS.	0/1
4	High Temperature Storage	Temp. : 100	1000 Hrs.	22 PCS.	0/1
5	Low Temperature Storage	Temp. : -40	1000 Hrs.	22 PCS.	0/1
6	DC Operating Life	IF = 20 mA	1000 Hrs.	22 PCS.	0/1
7	High Temperature / High Humidity	85 / 85%RH	1000 Hrs.	22 PCS.	0/1

**67-11/W1C-GP2R1B2Z/2T**

**Precautions For Use**

1. Over-current-proof

Customer must apply resistors for protection , otherwise slight voltage shift will cause big current change ( Burn out will happen ).

2. Storage

2.1 Do not open moisture proof bag before the products are ready to use.

2.2 Before opening the package, the LEDs should be kept at 30 or less and 90%RH or less.

2.3 After opening the package: The LED's floor life is 1 year under t 30 or less and 60% RH or less.

If unused LEDs remain, it should be stored in moisture proof packages.

2.4 If the moisture absorbent material (silica gel) has faded away or the LEDs have exceeded the storage time, baking treatment should be performed using the following conditions.

Baking treatment : 60±5 for 24 hours.

3. Soldering Condition

3.1 Pb-free solder temperature profile

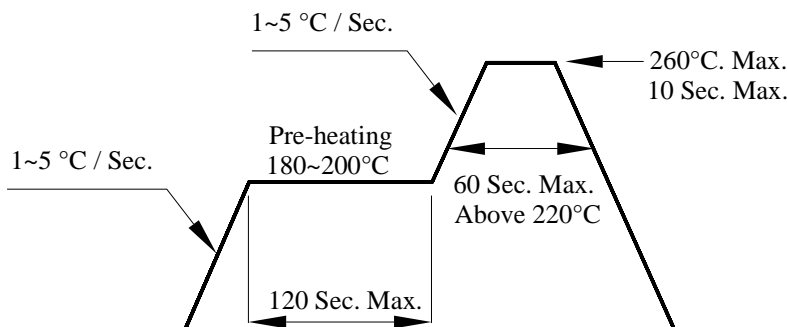

3.2 Reflow soldering should not be done more than two times.

3.3 When soldering, do not put stress on the LEDs during heating.

3.4 After soldering, do not warp the circuit board.

4.Soldering Iron

Each terminal is to go to the tip of soldering iron temperature less than 350 for 3 seconds within once in less than the soldering iron capacity 25W. Leave two seconds and more intervals, and do soldering of each terminal. Be careful because the damage of the product is often started at the time of the hand solder.

**67-11/W1C-GP2R1B2Z/2T****5.Repairing**

Repair should not be done after the LEDs have been soldered. When repairing is unavoidable, a double-head soldering iron should be used (as below figure). It should be confirmed beforehand whether the characteristics of the LEDs will or will not be damaged by repairing.

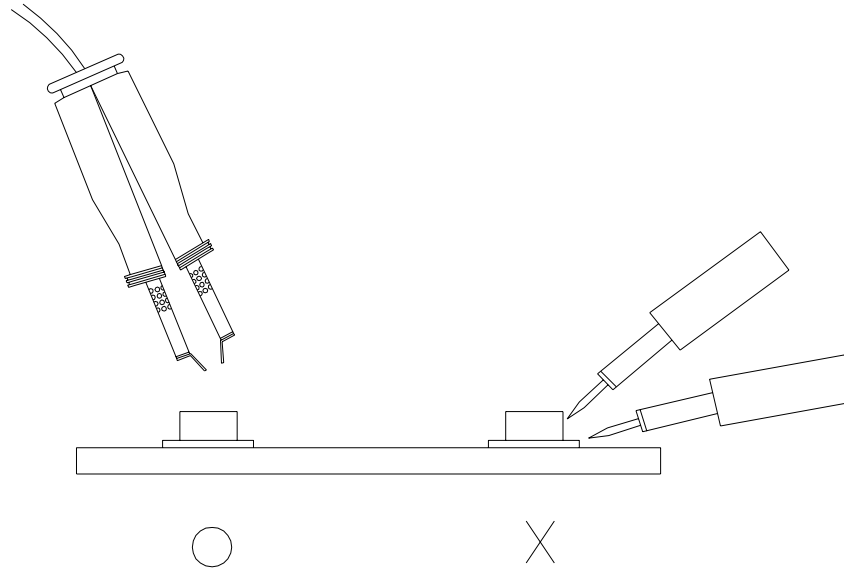
**EVERLIGHT ELECTRONICS CO., LTD.**

Office: No 25, Lane 76, Sec 3, Chung Yang Rd,  
Tucheng, Taipei 236, Taiwan, R.O.C

Tel: 886-2-2267-2000, 2267-9936

Fax: 886-2267-6244, 2267-6189, 2267-6306

<http://www.everlight.com>