

isc Silicon NPN Power Transistor

BU922

DESCRIPTION

- Collector-Emitter Sustaining Voltage-
: $V_{CEO(SUS)} = 450V(\text{Min})$

APPLICATIONS

- Designed for automotive ignition applications and inverter circuits for motor control.

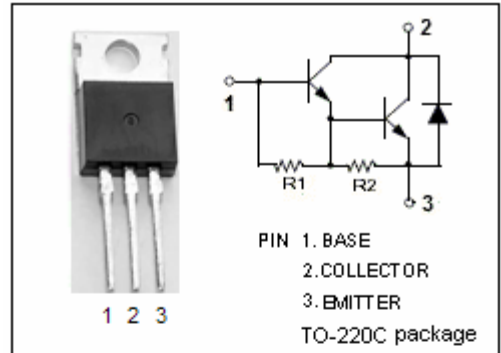

ABSOLUTE MAXIMUM RATINGS ($T_a=25^\circ\text{C}$)

SYMBOL	PARAMETER	VALUE	UNIT
V_{CES}	Collector-Emitter Voltage $V_{BE} = 0$	500	V
V_{CEO}	Collector-Emitter Voltage	450	V
V_{EBO}	Emitter-Base Voltage	5	V
I_C	Collector Current	10	A
I_{CM}	Collector Current-peak	15	A
I_B	Base Current	5	A
P_C	Collector Power Dissipation @ $T_C=25^\circ\text{C}$	105	W
T_j	Junction Temperature	150	$^\circ\text{C}$
T_{stg}	Storage Temperature Range	-65~150	$^\circ\text{C}$

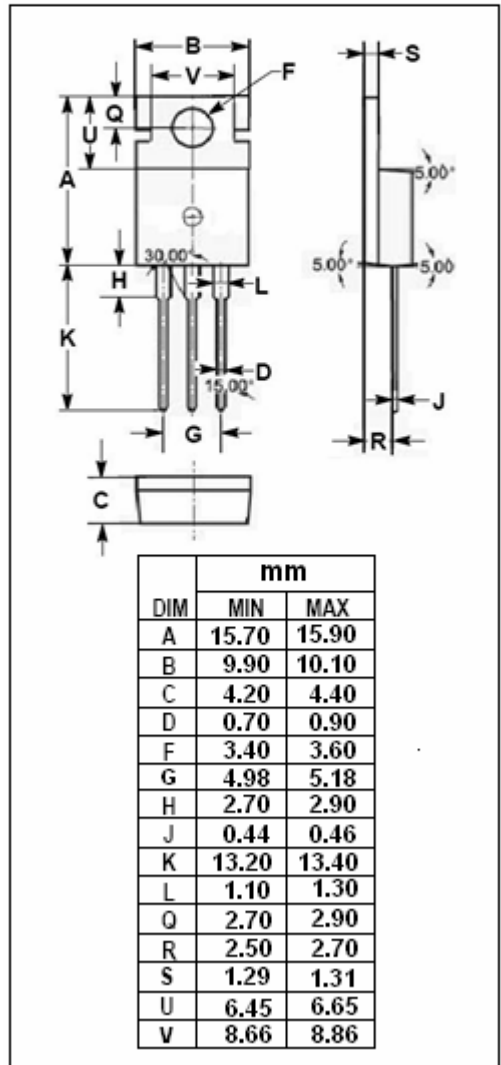

THERMAL CHARACTERISTICS

SYMBOL	PARAMETER	MAX	UNIT
$R_{th\ j-c}$	Thermal Resistance, Junction to Case	1.2	$^\circ\text{C/W}$

isc Silicon NPN Power Transistor

BU922

ELECTRICAL CHARACTERISTICS

 $T_C=25^{\circ}\text{C}$ unless otherwise specified

SYMBOL	PARAMETER	CONDITIONS	MIN	TYP.	MAX	UNIT
$V_{CEO(SUS)}$	Collector-Emitter Sustaining Voltage	$I_C=0.1\text{A}; I_B=0$	450			V
$V_{CE(sat)-1}$	Collector-Emitter Saturation Voltage	$I_C=5\text{A}; I_B=50\text{mA}$			1.8	V
$V_{CE(sat)-2}$	Collector-Emitter Saturation Voltage	$I_C=7\text{A}; I_B=140\text{mA}$			1.8	V
$V_{BE(sat)-1}$	Base-Emitter Saturation Voltage	$I_C=5\text{A}; I_B=50\text{mA}$			2.2	V
$V_{BE(sat)-2}$	Base-Emitter Saturation Voltage	$I_C=7\text{A}; I_B=140\text{mA}$			2.5	V
I_{CES}	Collector Cutoff Current	$V_{CE}=500\text{V}; V_{BE}=0$ $V_{CE}=500\text{V}; V_{BE}=0; T_j=150^{\circ}\text{C}$			0.25 0.5	mA
I_{CEO}	Collector Cutoff Current	$V_{CE}=450\text{V}; I_B=0$			0.25	mA
I_{EBO}	Emitter Cutoff Current	$V_{EB}=5\text{V}; I_C=0$			50	mA
V_{ECF}	C-E Diode Forward Voltage	$I_F=7\text{A}$			2.5	V