

1.5V 1:10 HSTL Fanout Buffer

Features

- DC to 150-MHz operation
- 1.5V power supply
- One single-ended HSTL input
- Ten single-ended Class II HSTL outputs
- Less than 1.9% Duty Cycle distortion
- Balanced 16-mA output drive
- Output Enable/Disable
- Low output-output skew
- Operating temperature range: 0°C to +85°C
- 32-pin TQFP package

Description

The CY2HH8110 is a low-voltage HSTL fanout buffer designed for data communications, clock management, and specialty memory applications.

The class II HSTL outputs are balanced Push-Pull in design capable of delivering 16 mA into 10 pF load. This class allows both source series termination and symmetrically double parallel termination.

The CY2HH8110 low-output duty cycle distortion makes it suitable for Double Data Rate (DDR) applications.

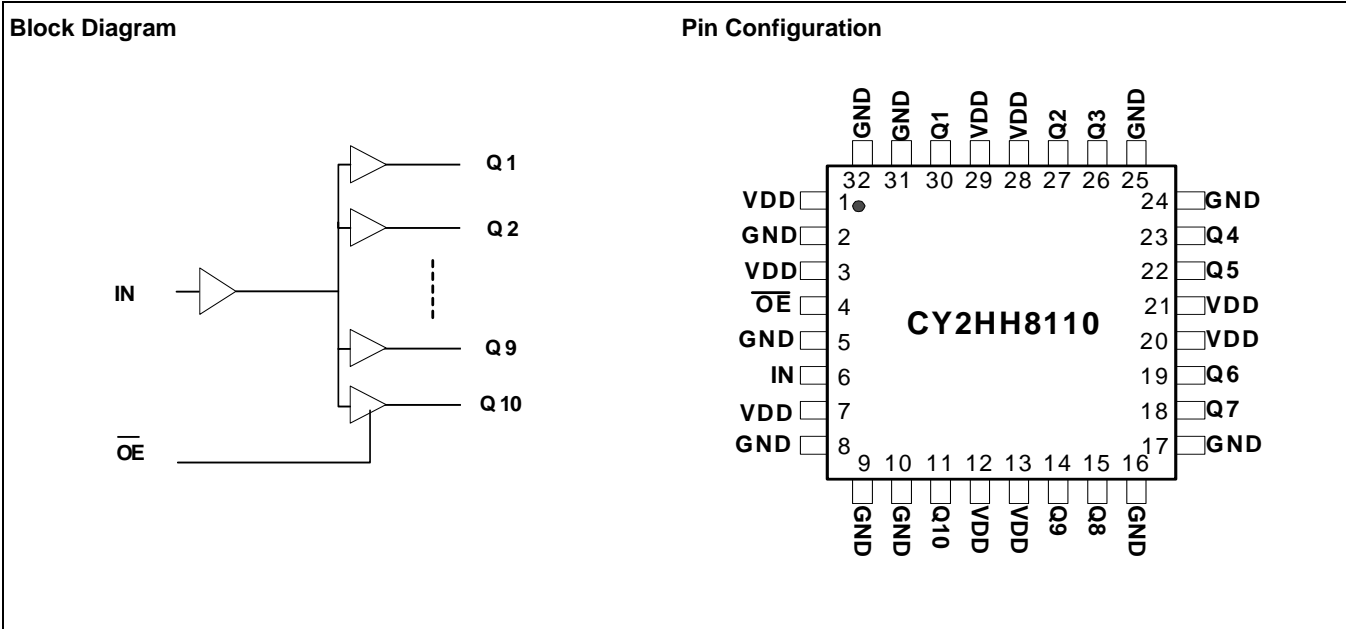

Pin Description^[1]

Pin	Name	I/O	Type	Description
6	IN	I	HSTL	HSTL reference clock input
30, 27, 26, 23, 22, 19, 18, 15, 14, 11	Q(1:10)	O	HSTL	HSTL clock outputs
4	OE	I, PD	LVC MOS	Output enable/disable input. When held LOW, outputs are enabled. When set HIGH, all outputs are disabled LOW.
1, 3, 7, 12, 13, 20, 21, 28, 29	VDD	Supply	VDD	1.5V power supply^[2]
2, 5, 8, 9, 10, 16, 17, 24, 25, 31, 32	GND	Supply	Ground	Common ground

Notes:

1. PD = Internal pull down.
2. A 0.1-uF bypass capacitor should be placed as close as possible to each positive power pin (< 0.2"). If these bypass capacitors are not close to the pins their high frequency filtering characteristics will be cancelled by the lead inductance of the trace.

Absolute Maximum Conditions

Parameter	Description	Condition	Min.	Max.	Unit
V _{DD}	DC Supply Voltage		-0.5	2.5	V
V _{DD}	DC Operating Voltage	Functional	1.35	1.65	V
V _{IN}	DC Input Voltage	Relative to V _{SS} , with or V _{DD} applied	-0.5	V _{DD} + 0.5	V
V _{OUT}	DC Output Voltage	Relative to V _{SS}	-0.5	V _{DD} + 0.5	V
V _{TT}	Output termination Voltage			V _{DD} ÷ 2	V
LU	Latch Up Immunity	Functional	200		mA
R _{PS}	Power Supply Ripple	Ripple Frequency < 100 kHz		150	mVp-p
T _S	Temperature, Storage	Non-functional	-65	+150	°C
T _A	Temperature, Operating Ambient	Functional	0	+85	°C
T _J	Temperature, Junction	Functional		+150	°C
∅ _{JC}	Dissipation, Junction to Case	Functional		42	°C/W
∅ _{JA}	Dissipation, Junction to Ambient	Functional		105	°C/W
ESD _H	ESD Protection (Human Body Model)		1600		V
FIT	Failure in Time	Manufacturing test		10	ppm

Multiple Supplies: The voltage on any input or I/O pin cannot exceed the power pin during power-up. Power supply sequencing is NOT required.

DC Electrical Specifications (V_{DD} = 1.5V ± 8%, T_A = 0°C to +85°C)

Parameter	Description	Condition	Min.	Typ.	Max.	Unit
V _{IL}	Input Voltage, Low	HSTL input, V _{REF} = 0.75V	-0.30	-	0.65	V
V _{IH}	Input Voltage, High		0.85	-	1.80	V
V _{IL}	Input Voltage, Low	OE# input	-0.30	-	0.3 * V _{DD}	V
V _{IH}	Input Voltage, High		0.7 * V _{DD}	-	V _{DD} + 0.3	V
V _{OL}	Output Voltage, Low ^[3]	I _{OL} = 16 mA	-0.3	-	0.4	V
V _{OH}	Output Voltage, High ^[3]	I _{OH} = -16 mA	1.0	-	V _{DD} + 0.3	V
I _{IL}	Input Current, Low ^[4]	V _{IL} = V _{SS}	-	-	-10	μA
I _{IH}	Input Current, High ^[4]	V _{IH} = V _{DD}	-	-	100	μA
I _{DDQ}	Quiescent Supply Current	V _{IN} = 0V, outputs disabled	-	-	1	mA
I _{DD}	Dynamic Supply Current	Outputs loaded @ 62.5 MHz	-	215	250	mA
C _{IN}	Input Pin Capacitance		-	-	6	pF
C _{OUT}	Output Pin Capacitance		-	4.5	6	pF
Z _{OUT}	Output Impedance		-	25	-	Ω

AC Electrical Specifications (V_{DD} = 1.5V ± 8%, T_A = 0°C to +85°C) ^[5]

Parameter	Description	Condition	Min.	Typ.	Max.	Unit
f _{in}	Input Frequency		-	-	150	MHz
V _{IL(AC)}	AC Input HIGH Voltage	V _{REF} = V _{DD} /2, Internal Voltage Reference	0.95	-		V
V _{IH(AC)}	AC Input LOW Voltage		-	-	0.55	V
t _r , t _f	Output rise/fall time ^[6]	20% to 80%	0.3	-	1.5	ns
DC	Output duty cycle	F _{out} < 100 MHz	48	-	52	%
		F _{out} > 100 MHz	45	-	55	

Notes:

- Driving 50Ω series terminated or symmetrically double parallel terminated transmission line to a termination voltage of V_{TT}.
- Inputs have pull-down resistors that affect the input current.
- AC characteristics apply for series or parallel output termination to V_{TT}. Parameters are guaranteed by characterization and are not 100% tested.
- t_r/t_f times are faster with parallel terminated loads.

AC Electrical Specifications ($V_{DD} = 1.5V \pm 8\%$, $T_A = 0^\circ C$ to $+85^\circ C$) (continued)^[5]

Parameter	Description	Condition	Min.	Typ.	Max.	Unit
tjit_DCD	Output Duty Cycle Distortion	Measure Jitter delay between input and output at $V_{DD}/2$ @ $f_{REF} = 62.5$ MHz	–	–	300	ps
		DCD @ $f_{REF} = 62.5$ MHz	–	–	1.9	%
t _{sk(O)}	Output-to-Output Skew		–	–	200	ps
t _{sk(pp)}	Part-to-Part Skew		–	–	2	ns
t _{PLH}	Propagation Delay, Low to High		–	–	7	ns
t _{PHL}	Propagation Delay, High to Low		–	–	7	ns
t _{Qoff}	Output Disable Time		–	–	7	ns
t _{Qon}	Output Enable Time		–	–	7	ns
t _{JIT(CC)}	Cycle-to-Cycle Jitter, Deterministic jitter		–	10	50	ps

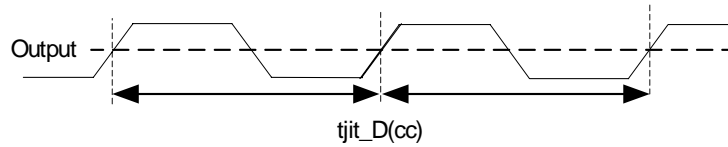
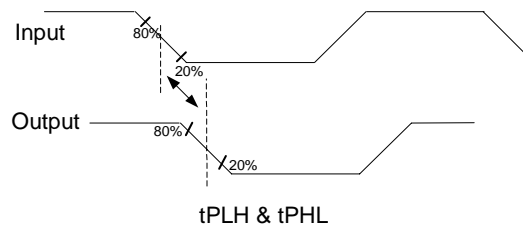
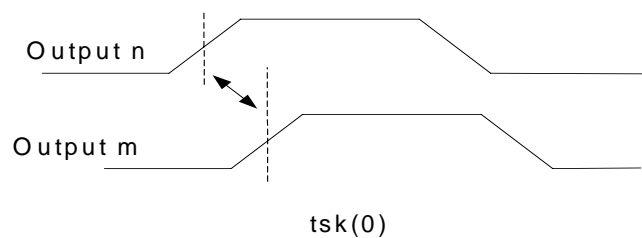
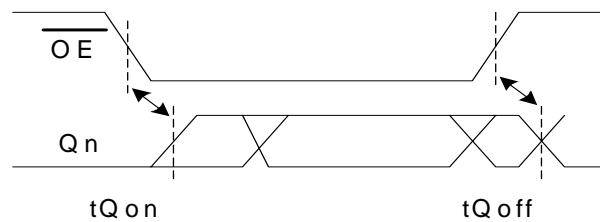
Parameter Measurement Information

Figure 1. Cycle-to-Cycle Jitter

Figure 2. Propagation Delay from Input Reference to Output *n*

Figure 3. Output to Output Skew

Figure 4. Output Enable/Disable Time

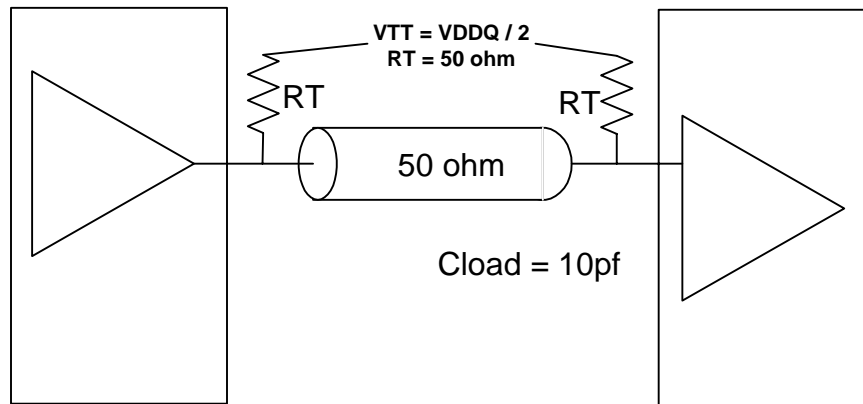

Figure 5. An Example HSTL Symmetrically Double Parallel Terminated Output Load | and CLASS II HSTL AC Test Load^[7,8]

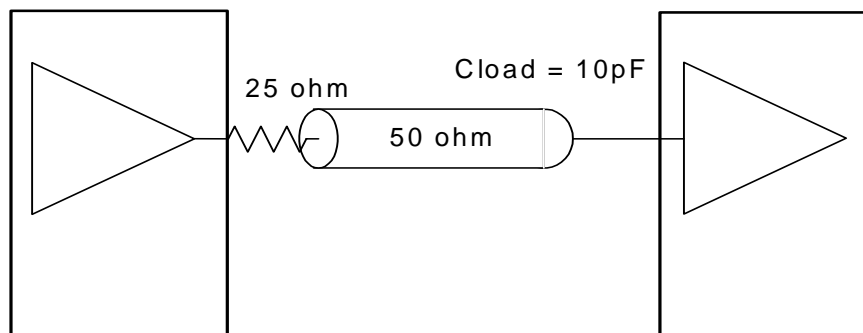

Figure 6. An Example HSTL Source Series Terminated Output Load^[7,8]

Ordering Information

Part Number	Package Type	Product Flow
CY2HH8110AC	32-pin TQFP	Commercial, 0°C to +85°C
CY2HH8110ACT	32-pin TQFP – Tape and Reel	

Notes:

- 7. HSTL to HSTL input.
- 8. Cload includes probe and test board capacitance.

Package Drawing and Dimensions

32-Lead Thin Plastic Quad Flatpack 7 x 7 x 1.0mm A32

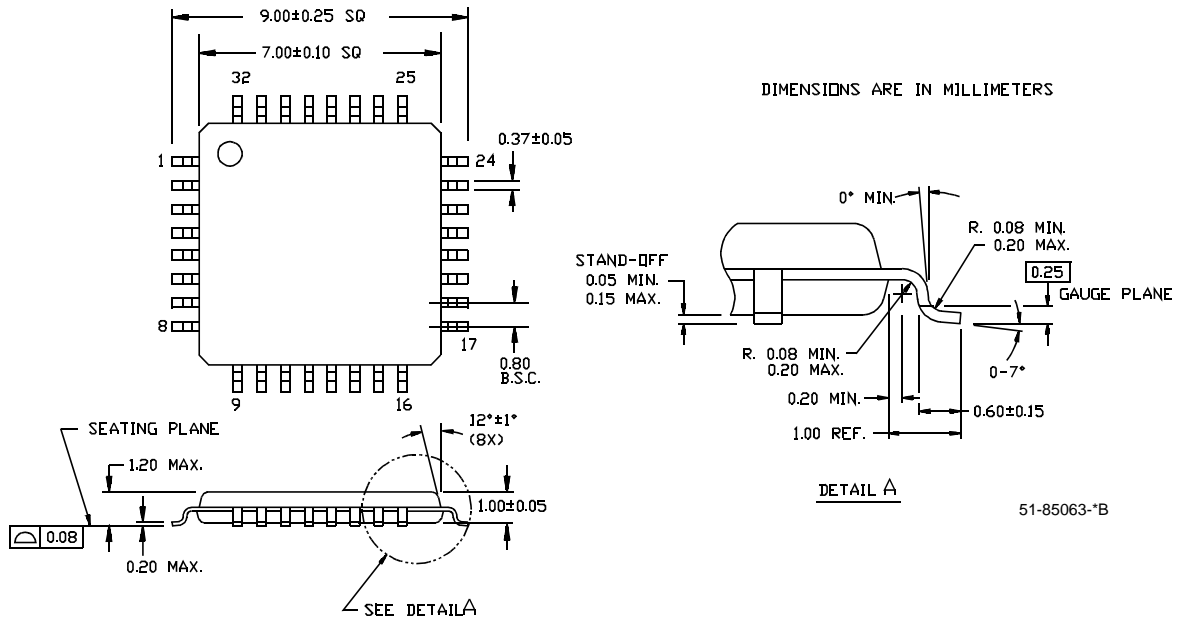

All product and company names mentioned in this document are the trademarks of their respective holders.

Document History Page

Document Title: CY2HH8110 1.5V 1:10 HSTL Fanout Buffer
Document Number: 38-07556

REV.	ECN No.	Issue Date	Orig. of Change	Description of Change
**	128398	08/04/03	RGL	New Data Sheet