

# HD74LVC2244A

## Octal Buffers / Line Drivers with 3-state Outputs

REJ03D0376-0300  
 (Previous ADE-205-234A (Z))  
 Rev.3.00  
 Aug. 20, 2004

### Description

The HD74LVC2244A has eight line drivers with three state outputs in a 20 pin package. This device is a noninverting buffer and has two active low enables ( $\overline{1G}$  and  $\overline{2G}$ ). Each enable independently controls four buffers.

All outputs, which are designed to sink up to 12mA, include equivalent 26  $\Omega$  resistors to reduce overshoot and undershoot.

Low voltage and high-speed operation is suitable at battery drive product (note type personal computer) and low power consumption extends the life of a battery for long time operation.

### Features

- $V_{CC} = 1.65$  to  $5.5$  V
- All inputs  $V_{IH} (\text{Max}) = 5.5$  V (@ $V_{CC} = 0$  to  $5.5$  V)
- All outputs  $V_O (\text{Max}) = 5.5$  V (@ $V_{CC} = 0$  V or output off state)
- Typical  $V_{OL}$  ground bounce  $< 0.8$  V (@ $V_{CC} = 3.3$  V,  $T_a = 25^\circ\text{C}$ )
- Typical  $V_{OH}$  undershoot  $> 2.0$  V (@ $V_{CC} = 3.3$  V,  $T_a = 25^\circ\text{C}$ )
- High output current  $\pm 12\text{mA}$  (@ $V_{CC} = 3.0$  to  $5.5$  V)
- All outputs have equivalent 26  $\Omega$  series resistors, so no external resistors are required
- Ordering Information

Part Name	Package Type	Package Code	Package Abbreviation	Taping Abbreviation (Quantity)
HD74LVC2244AFPEL	SOP-20 pin (JEITA)	FP-20DAV	FP	EL (2,000 pcs/reel)
HD74LVC2244ATELL	TSSOP-20 pin	TTP-20DAV	T	ELL (2,000 pcs/reel)

Note: Please consult the sales office for the above package availability.

### Function Table

#### Inputs

$\overline{G}$	A	Output Y
H	X	Z
L	H	H
L	L	L

H: High level

L: Low level

X: Immaterial

Z: High impedance

Pin Arrangement

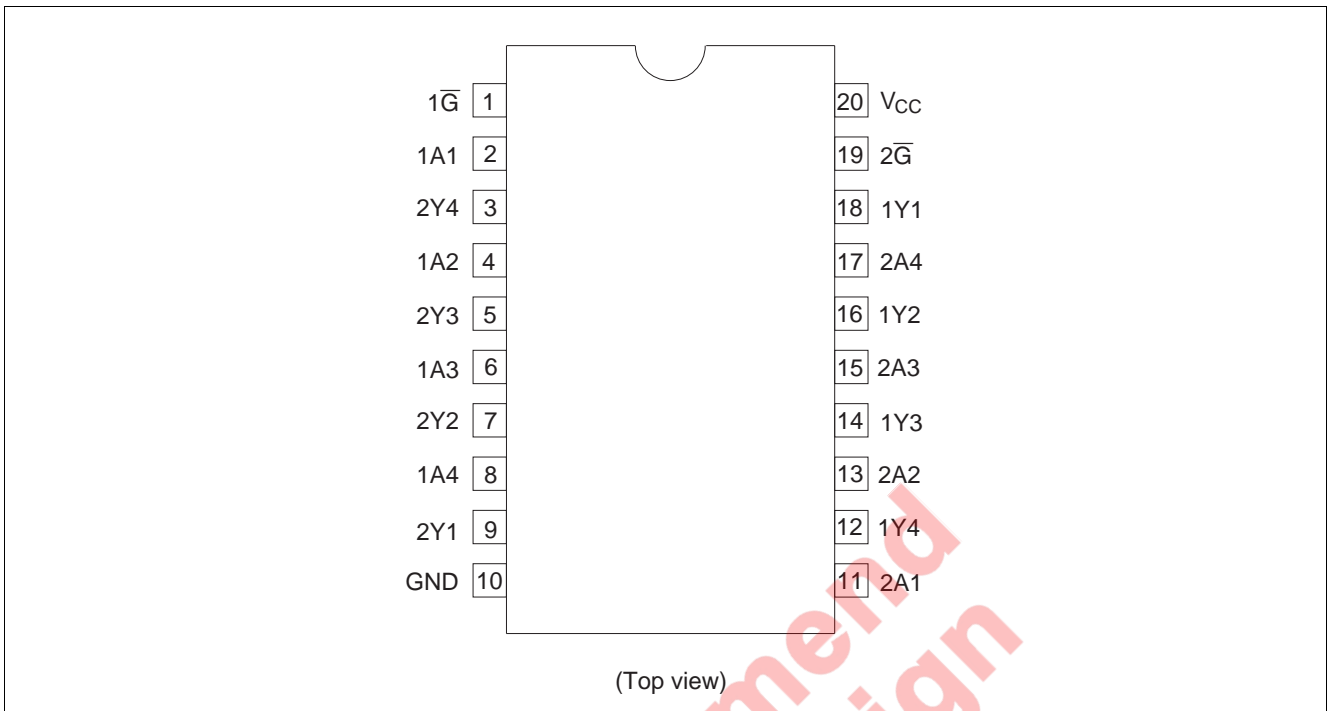

Absolute Maximum Ratings

Item	Symbol	Ratings	Unit	Conditions
Supply voltage	V <sub>CC</sub>	-0.5 to 7.0	V	
Input voltage	V <sub>I</sub>	-0.5 to 7.0	V	
Output voltage	V <sub>O</sub>	-0.5 to 7.0	V	Output "Z" or V <sub>CC</sub> : OFF
		-0.5 to V <sub>CC</sub> +0.5		Output "H" or "L"
Input diode current	I <sub>IK</sub>	-50	mA	V <sub>I</sub> < 0
Output diode current	I <sub>OK</sub>	-50	mA	V <sub>O</sub> < 0
Output current	I <sub>O</sub>	±50	mA	
V <sub>CC</sub> , GND current	I <sub>CC</sub> or I <sub>GND</sub>	±100	mA	
Storage temperature	T <sub>stg</sub>	-65 to 150	°C	

Note: The absolute maximum ratings are values, which must not individually be exceeded, and furthermore no two of which may be realized at the same time.

**Recommended Operating Conditions**

Item	Symbol	Ratings	Unit	Conditions
Supply voltage	$V_{CC}$	1.65 to 5.5	V	At operation
		1.5 to 5.5		Data retention only
Input voltage	$V_I$	0 to 5.5	V	
Output voltage	$V_O$	0 to 5.5	V	Output "Z" or $V_{CC}$ : OFF
		0 to $V_{CC}$		Output "H" or "L"
Output current	$I_{OH}$	-2	mA	$V_{CC} = 1.65\text{ V}$
		-4		$V_{CC} = 2.3\text{ V}$
		-8		$V_{CC} = 2.7\text{ V}$
		-12		$V_{CC} = 3.0\text{ to }5.5\text{ V}$
	$I_{OL}$	2	mA	$V_{CC} = 1.65\text{ V}$
		4		$V_{CC} = 2.3\text{ V}$
		8		$V_{CC} = 2.7\text{ V}$
		12		$V_{CC} = 3.0\text{ to }5.5\text{ V}$
Input rise / fall time	$t_r, t_f$	0 to 6	ns / V	
Operating temperature	$T_a$	-40 to +85	°C	

**Logic Diagram**

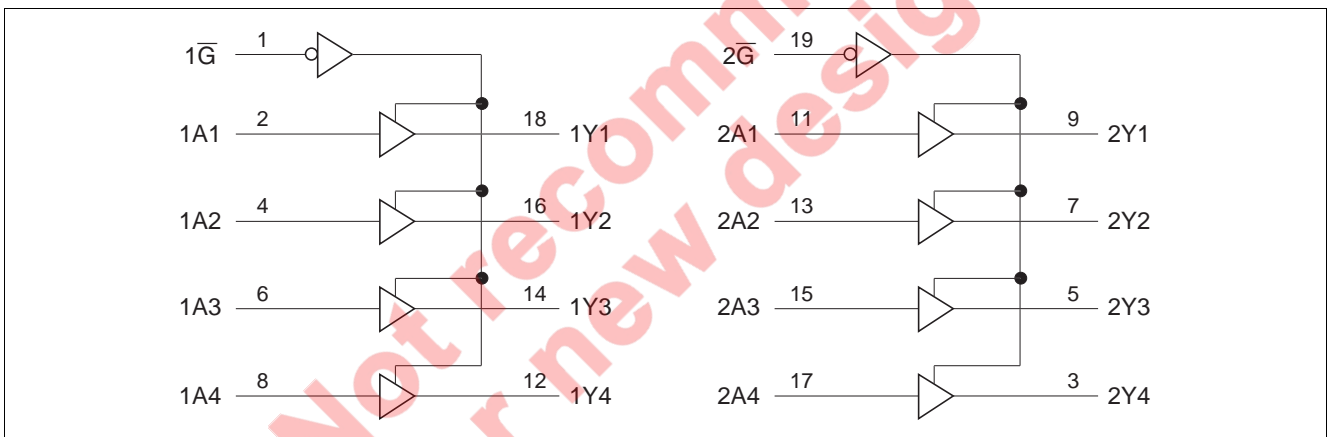

Electrical Characteristics

(Ta = -40 to 85°C)

Item	Symbol	V <sub>CC</sub> (V)	Min	Typ	Max	Unit	Test Conditions
Input voltage	V <sub>IH</sub>	1.65 to 1.95	V <sub>CC</sub> ×0.65	—	—	V	
		2.3 to 2.7	1.7	—	—		
		2.7 to 3.6	2.0	—	—		
		4.5 to 5.5	V <sub>CC</sub> ×0.7	—	—		
	V <sub>IL</sub>	1.65 to 1.95	—	—	V <sub>CC</sub> ×0.35	V	
		2.3 to 2.7	—	—	0.7		
		2.7 to 3.6	—	—	0.8		
		4.5 to 5.5	—	—	V <sub>CC</sub> ×0.3		
Output voltage	V <sub>OH</sub>	1.65 to 5.5	V <sub>CC</sub> -0.2	—	—	V	I <sub>OH</sub> = -100 μA
		1.65	1.2	—	—		I <sub>OH</sub> = -2 mA
		2.3	1.7	—	—		I <sub>OH</sub> = -4 mA
		2.7	2.2	—	—		
		3.0	2.4	—	—		I <sub>OH</sub> = -6 mA
		2.7	2.0	—	—		I <sub>OH</sub> = -8 mA
		3.0	2.0	—	—		I <sub>OH</sub> = -12 mA
		4.5	3.6	—	—		
	V <sub>OL</sub>	1.65 to 5.5	—	—	0.2	V	I <sub>OL</sub> = 100 μA
		1.65	—	—	0.45		I <sub>OL</sub> = 2 mA
		2.3	—	—	0.7		I <sub>OL</sub> = 4 mA
		2.7	—	—	0.4		
		3.0	—	—	0.55		I <sub>OL</sub> = 6 mA
		2.7	—	—	0.6		I <sub>OL</sub> = 8 mA
3.0	—	—	0.8	I <sub>OL</sub> = 12 mA			
4.5	—	—	0.8				
Input current	I <sub>IN</sub>	0 to 5.5	—	—	±5	μA	V <sub>IN</sub> = 0 to 5.5 V
Off state output current	I <sub>OZ</sub>	1.65 to 5.5	—	—	±5	μA	V <sub>OUT</sub> = 0 to 5.5 V
Output leak current	I <sub>OFF</sub>	0	—	—	±5	μA	V <sub>IN</sub> or V <sub>O</sub> = 5.5 V
Quiescent supply current	I <sub>CC</sub>	1.65 to 3.6	—	—	10	μA	V <sub>IN</sub> = 3.6 to 5.5 V <sup>*1</sup> , I <sub>O</sub> = 0
		1.65 to 5.5	—	—	10		V <sub>IN</sub> = V <sub>CC</sub> or GND
	ΔI <sub>CC</sub>	2.7 to 3.6	—	—	500	μA	V <sub>IN</sub> = one input at (V <sub>CC</sub> -0.6)V, other inputs at V <sub>CC</sub> or GND
Input capacitance	C <sub>IN</sub>	3.3	—	3.4	—	pF	V <sub>IN</sub> = V <sub>CC</sub> or GND
Output capacitance	C <sub>O</sub>	3.3	—	9.0	—	pF	V <sub>OUT</sub> = V <sub>CC</sub> or GND

Note: 1. This applies in the disabled state only.

Switching Characteristics

(Ta = -40 to 85°C)

Item	Symbol	V <sub>CC</sub> (V)	Min	Typ	Max	Unit	FROM (Input)	TO (Output)
Propagation delay time	t <sub>PLH</sub>	1.8±0.15	—	—	10.5	ns	A	Y
		2.5±0.2	—	—	7.0			
	2.7	—	—	6.4				
	3.3±0.3	1.5	—	5.5				
	5.0±0.5	—	—	4.1				
Output enable time	t <sub>ZH</sub>	1.8±0.15	—	—	13.0	ns	$\bar{G}$	Y
		2.5±0.2	—	—	9.0			
	2.7	—	—	8.1				
	3.3±0.3	1.0	—	7.1				
	5.0±0.5	—	—	5.6				
Output disable time	t <sub>HZ</sub>	1.8±0.15	—	—	10.0	ns	$\bar{G}$	Y
		2.5±0.2	—	—	8.0			
	2.7	—	—	7.3				
	3.3±0.3	1.5	—	6.8				
	5.0±0.5	—	—	5.7				
Between output pin skew <sup>*1</sup>	t <sub>OSLH</sub>	1.8±0.15	—	—	2.0	ns		
		2.5±0.2	—	—	2.0			
	2.7	—	—	1.5				
	3.3±0.3	—	—	1.0				
	5.0±0.5	—	—	1.0				

Note: 1. This parameter is characterized but not tested.

$$t_{OSLH} = |t_{PLHm} - t_{PLHn}|, t_{OSHL} = |t_{PHLm} - t_{PHLn}|$$

Not recommended for new design

Test Circuit

( $V_{CC} = 1.8 \pm 0.15 \text{ V}$ ,  $V_{CC} = 2.5 \pm 0.2 \text{ V}$ )

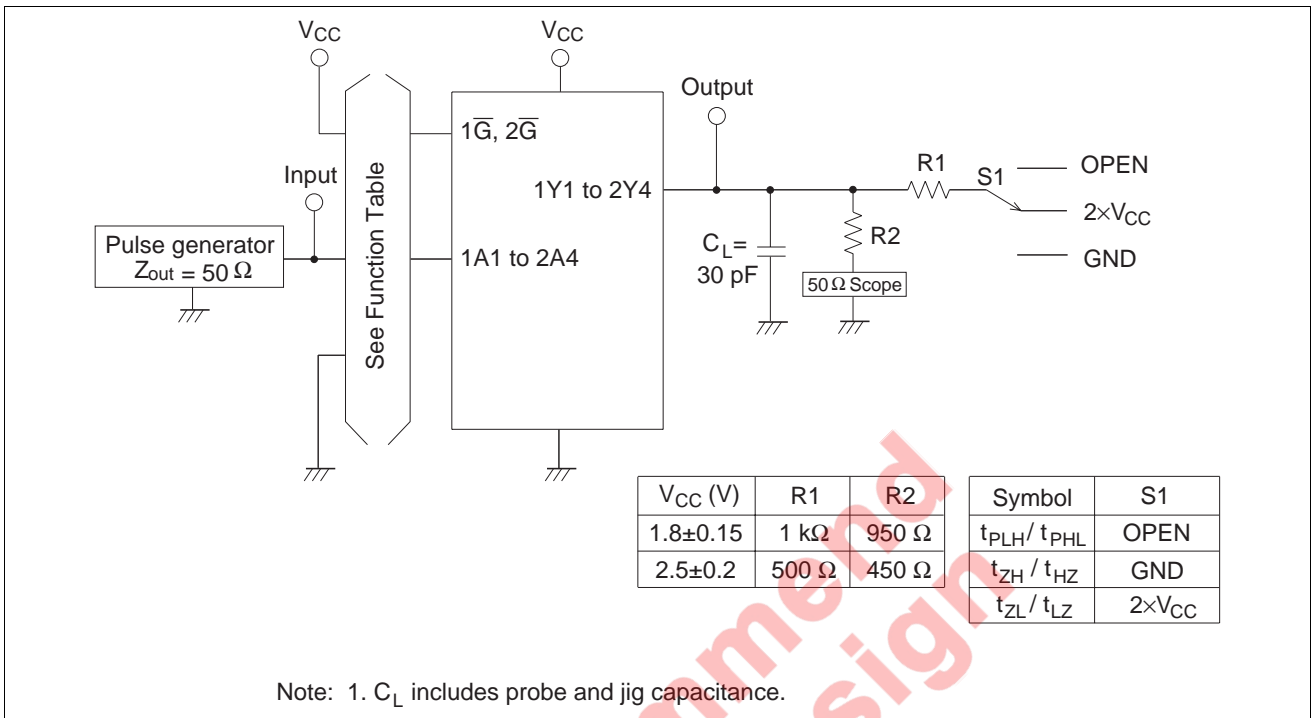

( $V_{CC} = 2.7 \text{ V}$ ,  $V_{CC} = 3.3 \pm 0.3 \text{ V}$ ,  $V_{CC} = 5.0 \pm 0.5 \text{ V}$ )

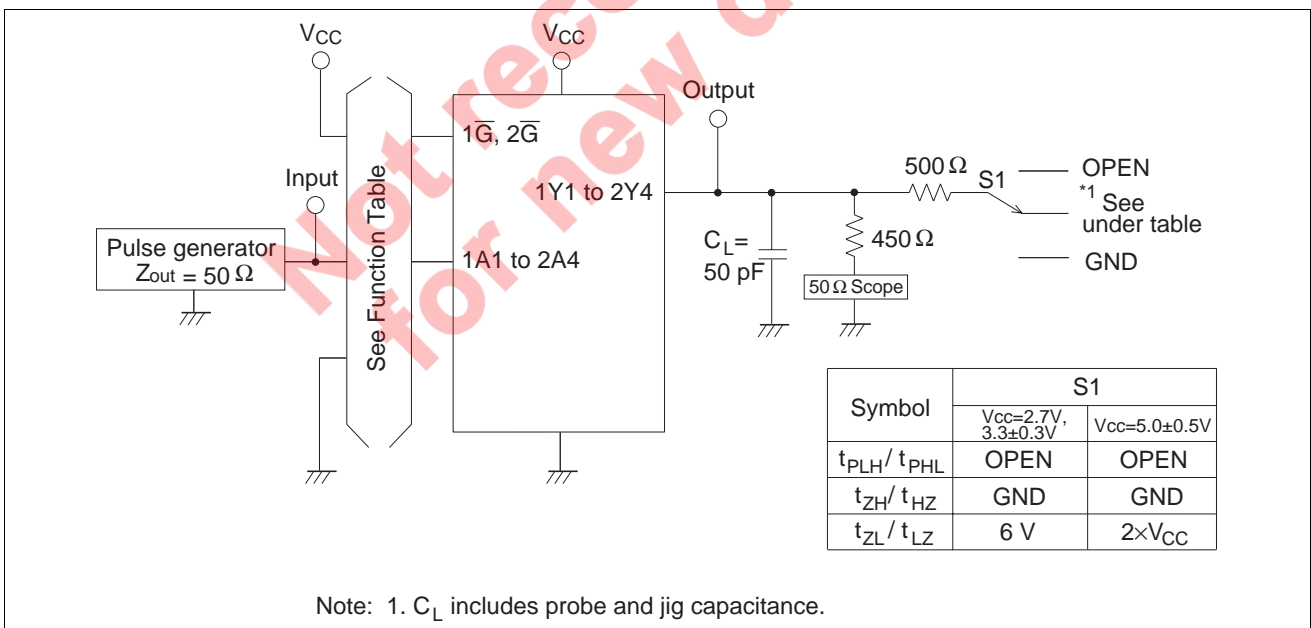

Waveforms

( $V_{CC} = 1.8 \pm 0.15 \text{ V}$ ,  $V_{CC} = 2.5 \pm 0.2 \text{ V}$ )

• Waveforms – 1

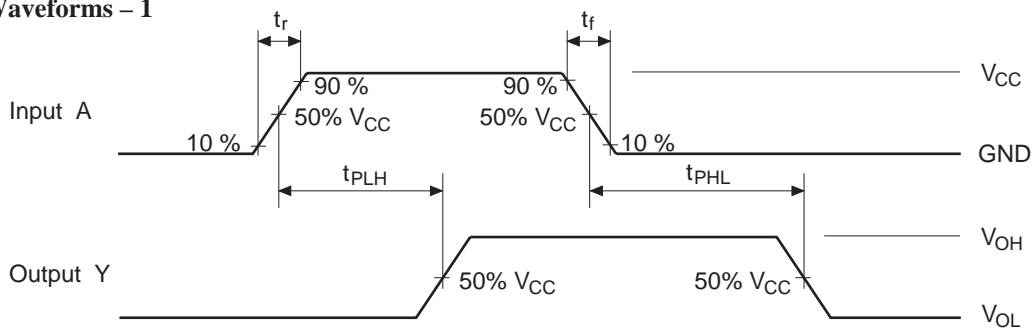

• Waveforms – 2

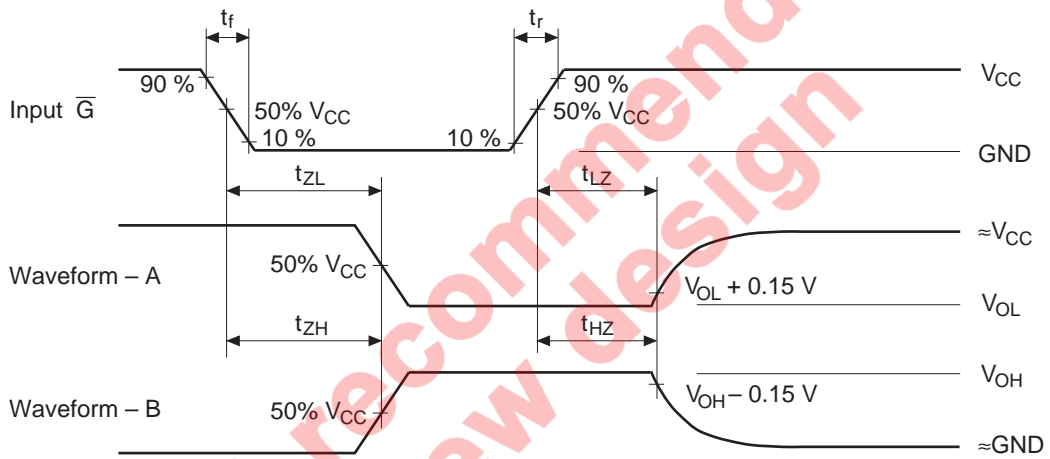

- Notes:
1. Input waveform : PRR = 10 MHz, duty cycle 50%,  $t_r = 2.0 \text{ ns}$ ,  $t_f = 2.0 \text{ ns}$
  2. Waveform – A shows input conditions such that the output is "L" level when enabled by the output control.
  3. Waveform – B shows input conditions such that the output is "H" level when enabled by the output control.

• Waveforms – 1

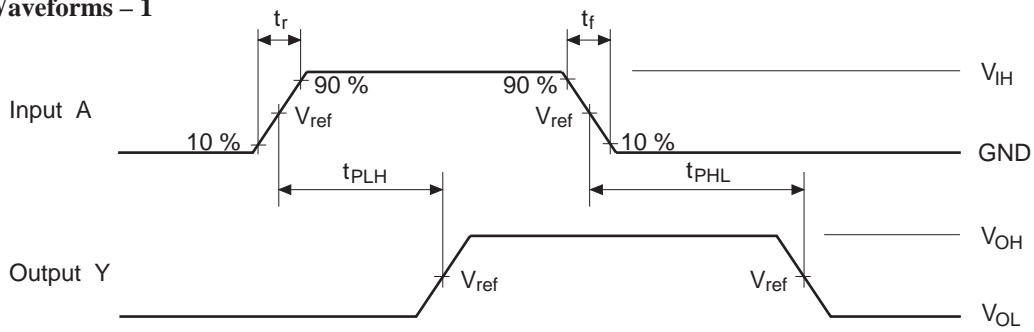

• Waveforms – 2

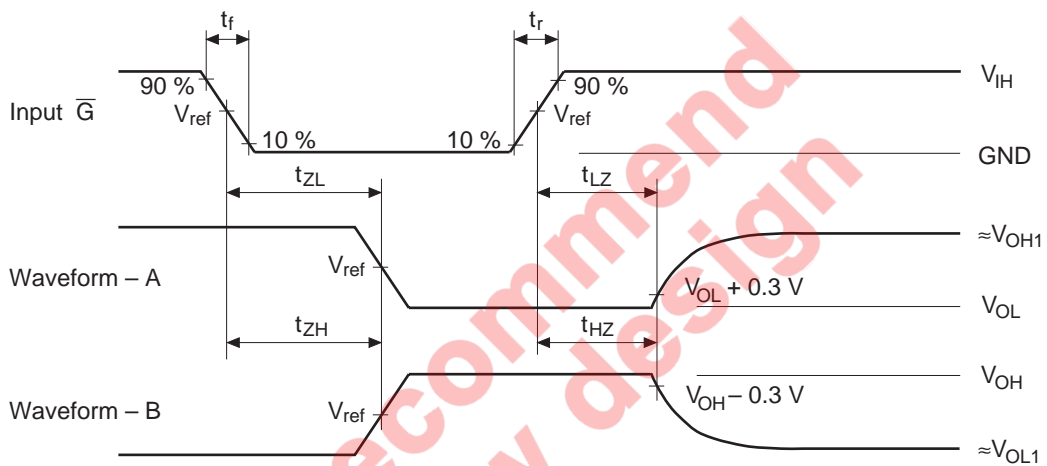

TEST	$V_{CC}=2.7\text{V}, 3.3 \pm 0.3\text{V}$	$V_{CC}=5.0 \pm 0.5\text{V}$
$V_{IH}$	2.7 V	$V_{CC}$
$V_{ref}$	1.5 V	$50\%V_{CC}$
$V_{OH1}$	3 V	$V_{CC}$
$V_{OL1}$	GND	GND

- Notes: 1. Input waveform : PRR = 10 MHz, duty cycle 50%,  $t_r = 2.5\text{ ns}$ ,  $t_f = 2.5\text{ ns}$   
 2. Waveform – A shows input conditions such that the output is "L" level when enabled by the output control.  
 3. Waveform – B shows input conditions such that the output is "H" level when enabled by the output control.



Package Dimensions

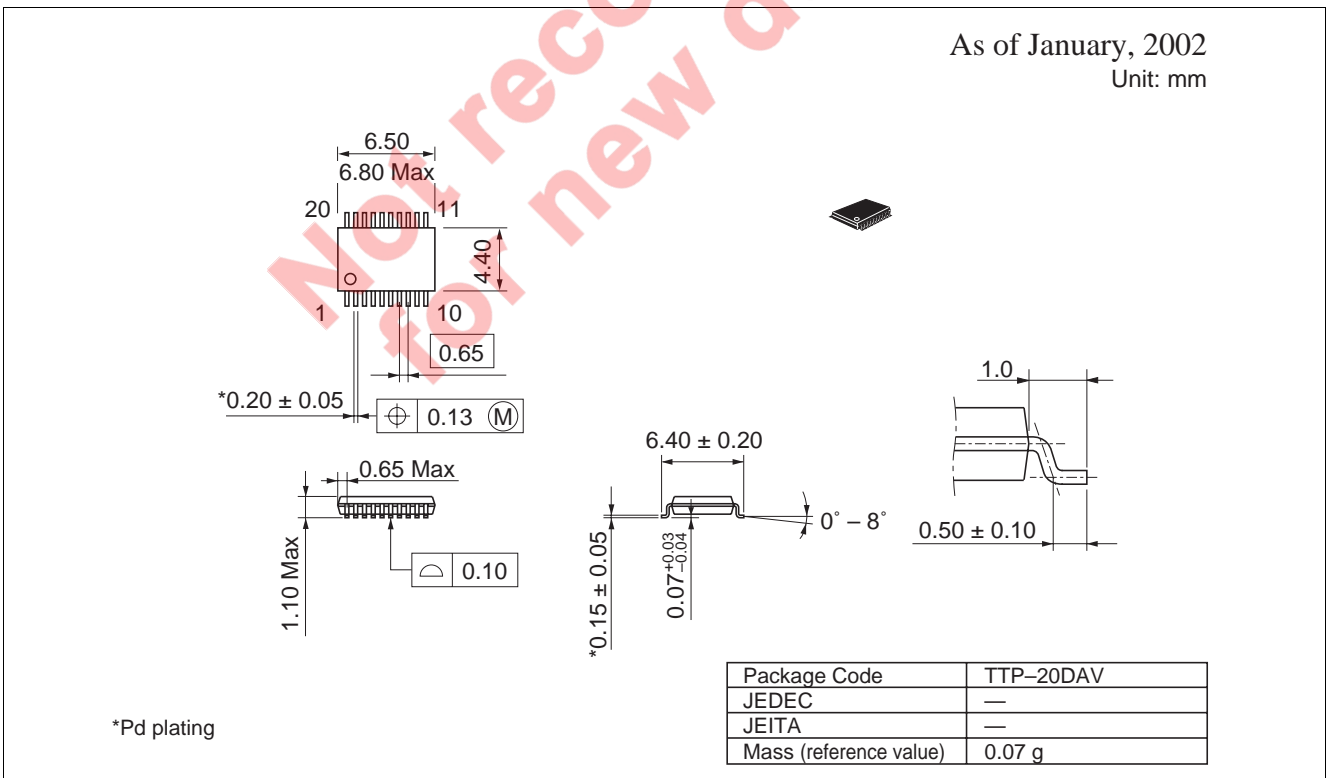
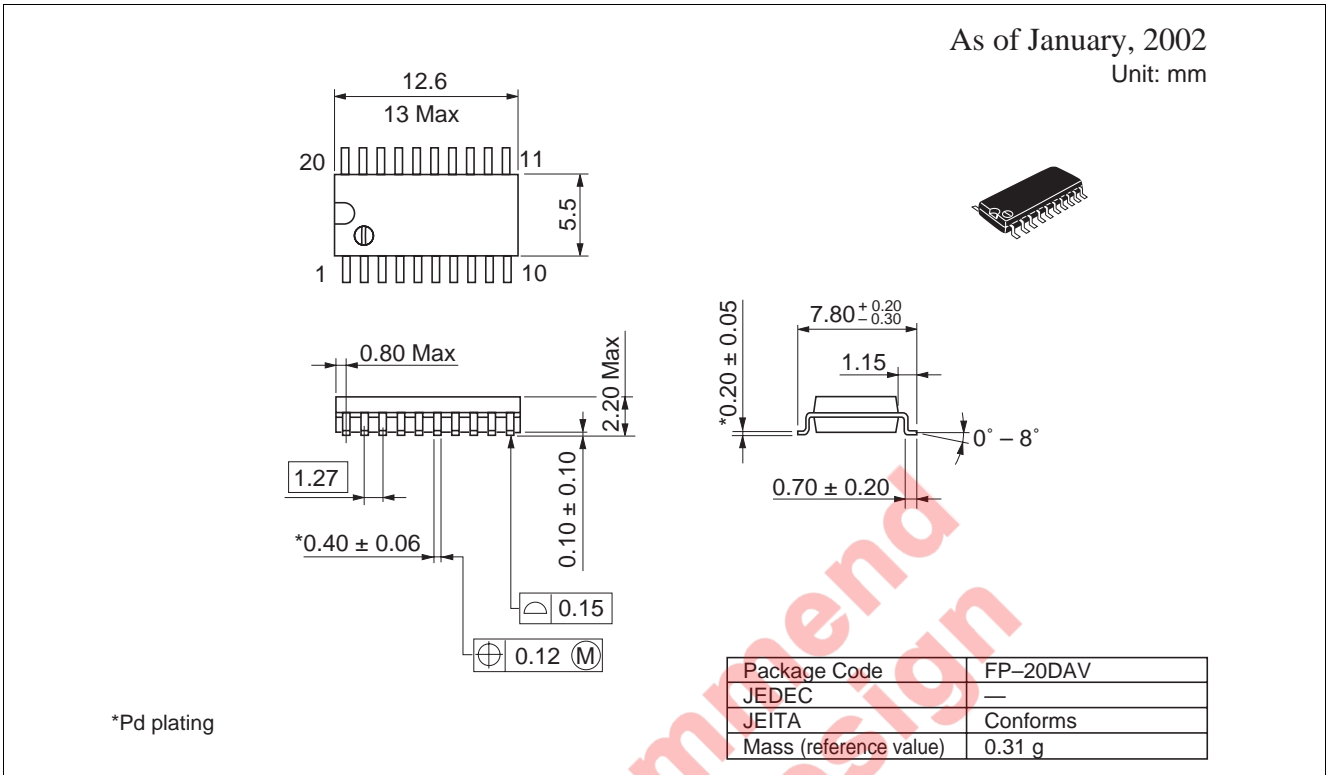

Keep safety first in your circuit designs!

1. Renesas Technology Corp. puts the maximum effort into making semiconductor products better and more reliable, but there is always the possibility that trouble may occur with them. Trouble with semiconductors may lead to personal injury, fire or property damage. Remember to give due consideration to safety when making your circuit designs, with appropriate measures such as (i) placement of substitutive, auxiliary circuits, (ii) use of nonflammable material or (iii) prevention against any malfunction or mishap.

Notes regarding these materials

1. These materials are intended as a reference to assist our customers in the selection of the Renesas Technology Corp. product best suited to the customer's application; they do not convey any license under any intellectual property rights, or any other rights, belonging to Renesas Technology Corp. or a third party.
  2. Renesas Technology Corp. assumes no responsibility for any damage, or infringement of any third-party's rights, originating in the use of any product data, diagrams, charts, programs, algorithms, or circuit application examples contained in these materials.
  3. All information contained in these materials, including product data, diagrams, charts, programs and algorithms represents information on products at the time of publication of these materials, and are subject to change by Renesas Technology Corp. without notice due to product improvements or other reasons. It is therefore recommended that customers contact Renesas Technology Corp. or an authorized Renesas Technology Corp. product distributor for the latest product information before purchasing a product listed herein.  
The information described here may contain technical inaccuracies or typographical errors.  
Renesas Technology Corp. assumes no responsibility for any damage, liability, or other loss rising from these inaccuracies or errors.  
Please also pay attention to information published by Renesas Technology Corp. by various means, including the Renesas Technology Corp. Semiconductor home page (<http://www.renesas.com>).
  4. When using any or all of the information contained in these materials, including product data, diagrams, charts, programs, and algorithms, please be sure to evaluate all information as a total system before making a final decision on the applicability of the information and products. Renesas Technology Corp. assumes no responsibility for any damage, liability or other loss resulting from the information contained herein.
  5. Renesas Technology Corp. semiconductors are not designed or manufactured for use in a device or system that is used under circumstances in which human life is potentially at stake. Please contact Renesas Technology Corp. or an authorized Renesas Technology Corp. product distributor when considering the use of a product contained herein for any specific purposes, such as apparatus or systems for transportation, vehicular, medical, aerospace, nuclear, or undersea repeater use.
  6. The prior written approval of Renesas Technology Corp. is necessary to reprint or reproduce in whole or in part these materials.
  7. If these products or technologies are subject to the Japanese export control restrictions, they must be exported under a license from the Japanese government and cannot be imported into a country other than the approved destination.  
Any diversion or reexport contrary to the export control laws and regulations of Japan and/or the country of destination is prohibited.
  8. Please contact Renesas Technology Corp. for further details on these materials or the products contained therein.
- 



## RENESAS SALES OFFICES

<http://www.renesas.com>

### **Renesas Technology America, Inc.**

450 Holger Way, San Jose, CA 95134-1368, U.S.A  
Tel: <1> (408) 382-7500 Fax: <1> (408) 382-7501

### **Renesas Technology Europe Limited.**

Dukes Meadow, Millboard Road, Bourne End, Buckinghamshire, SL8 5FH, United Kingdom  
Tel: <44> (1628) 585 100, Fax: <44> (1628) 585 900

### **Renesas Technology Europe GmbH**

Dornacher Str. 3, D-85622 Feldkirchen, Germany  
Tel: <49> (89) 380 70 0, Fax: <49> (89) 929 30 11

### **Renesas Technology Hong Kong Ltd.**

7/F., North Tower, World Finance Centre, Harbour City, Canton Road, Hong Kong  
Tel: <852> 2265-6688, Fax: <852> 2375-6836

### **Renesas Technology Taiwan Co., Ltd.**

FL 10, #99, Fu-Hsing N. Rd., Taipei, Taiwan  
Tel: <886> (2) 2715-2888, Fax: <886> (2) 2713-2999

### **Renesas Technology (Shanghai) Co., Ltd.**

26/F., Ruijin Building, No.205 Maoming Road (S), Shanghai 200020, China  
Tel: <86> (21) 6472-1001, Fax: <86> (21) 6415-2952

### **Renesas Technology Singapore Pte. Ltd.**

1, Harbour Front Avenue, #06-10, Keppel Bay Tower, Singapore 098632  
Tel: <65> 6213-0200, Fax: <65> 6278-8001