



## 19N10

Preliminary

Power MOSFET

### 100V N-Channel MOSFET

#### DESCRIPTION

The UTC 100V N-Channel enhancement mode power field effect transistors (MOSFET) are produced by UTC's planar stripe, DMOS technology which has been tailored especially in the avalanche and commutation mode to minimize on-state resistance, provide superior switching performance, and withstand high energy pulse. They are suited for low voltage applications such as audio amplifier, high efficiency switching DC/DC converters, and DC motor control.

#### FEATURES

- \*  $R_{DS(ON)} = 0.1\Omega @ V_{GS} = 10V$
- \* Ultra low gate charge ( typical 19nC )
- \* Low reverse transfer Capacitance (  $C_{RSS} =$  typical 32pF )
- \* Fast switching capability
- \* Avalanche energy Specified
- \* Improved dv/dt capability, high ruggedness

#### SYMBOL

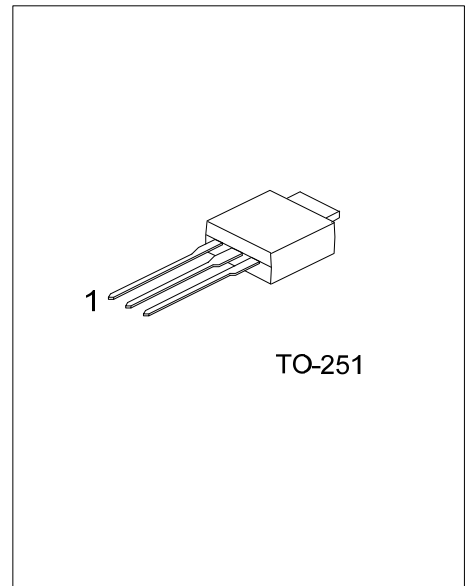
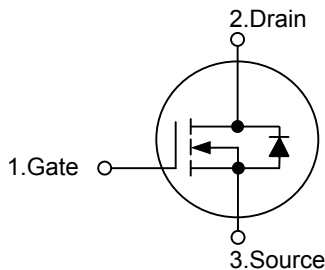

Lead-free: 19N10L  
 Halogen-free: 19N10G

#### ORDERING INFORMATION

Ordering Number			Package	Pin Assignment			Packing
Normal	Lead Free	Halogen Free		1	2	3	
19N10-TM3-T	19N10L-TM3-T	19N10G-TM3-T	TO-251	G	D	S	Tube

<p>19N10L-TM3-T</p>	<p>(1) T: Tube</p> <p>(2) TM3: TO-251</p> <p>(3) G: Halogen Free, L: Lead Free, Blank: Pb/Sn</p>
---------------------	--

■ ABSOLUTE MAXIMUM RATINGS ( $T_C=25^\circ\text{C}$ , unless otherwise specified)

PARAMETER	SYMBOL	RATINGS	UNIT
Drain-Source Voltage	$V_{DSS}$	100	V
Gate-Source Voltage	$V_{GSS}$	$\pm 25$	V
Continuous Drain Current	$I_D$	15.6	A
Pulsed Drain Current (Note 2)	$I_{DM}$	62.4	A
Avalanche Current (Note 2)	$I_{AR}$	15.6	A
Single Pulsed Avalanche Energy (Note 3)	$E_{AS}$	220	mJ
Repetitive Avalanche Energy (Note 2)	$E_{AR}$	5.0	mJ
Peak Diode Recovery dv/dt (Note 4)	dv/dt	6.0	V/ns
Power Dissipation	$P_D$	50	W
Derate above $25^\circ\text{C}$		0.4	W/ $^\circ\text{C}$
Junction Temperature	$T_J$	+150	$^\circ\text{C}$
Storage Temperature	$T_{STG}$	-55 ~ +150	$^\circ\text{C}$

Note: 1. Absolute maximum ratings are those values beyond which the device could be permanently damaged.

Absolute maximum ratings are stress ratings only and functional device operation is not implied.

- Pulse width limited by  $T_{J(MAX)}$
- $L=1.35\text{mH}$ ,  $I_{AS}=15.6\text{A}$ ,  $V_{DD}=25\text{V}$ ,  $R_G=25\ \Omega$ , Starting  $T_J=25^\circ\text{C}$
- $I_{SD}\leq 19\text{A}$ ,  $di/dt \leq 300\text{A}/\mu\text{s}$ ,  $V_{DD}\leq BV_{DSS}$ , Starting  $T_J=25^\circ\text{C}$

■ THERMAL DATA

PARAMETER	SYMBOL	RATINGS	UNIT
Junction-to-Ambient	$\theta_{JA}$	110	$^\circ\text{C}/\text{W}$
Junction-to-Case	$\theta_{JC}$	2.5	$^\circ\text{C}/\text{W}$

■ ELECTRICAL CHARACTERISTICS ( $T_J=25^\circ\text{C}$ , unless otherwise specified)

PARAMETER	SYMBOL	TEST CONDITIONS	MIN	TYP	MAX	UNIT
<b>OFF CHARACTERISTICS</b>						
Drain-Source Breakdown Voltage	$BV_{DSS}$	$V_{GS}=0\text{V}$ , $I_D=250\mu\text{A}$	100			V
Breakdown Voltage Temperature Coefficient	$\frac{\Delta BV_{DSS}}{\Delta T_J}$	$I_D=250\mu\text{A}$ , Referenced to $25^\circ\text{C}$		0.1		V/ $^\circ\text{C}$
Drain-Source Leakage Current	$I_{DSS}$	$V_{DS}=100\text{V}$ , $V_{GS}=0\text{V}$			1	$\mu\text{A}$
Gate-Source Leakage Current	Forward Reverse	$I_{GSS}$	$V_{GS}=25\text{V}$ , $V_{DS}=0\text{V}$		100	nA
			$V_{GS}=-25\text{V}$ , $V_{DS}=0\text{V}$		-100	
<b>ON CHARACTERISTICS</b>						
Gate Threshold Voltage	$V_{GS(TH)}$	$V_{DS}=V_{GS}$ , $I_D=250\mu\text{A}$	2.0		4.0	V
Static Drain-Source On-Resistance	$R_{DS(ON)}$	$V_{GS}=10\text{V}$ , $I_D=7.8\text{A}$		0.078	0.1	$\Omega$
Forward Transconductance	$g_{FS}$	$V_{DS}=40\text{V}$ , $I_D=7.8\text{A}$ (Note 1)		11		S
<b>DYNAMIC PARAMETERS</b>						
Input Capacitance	$C_{ISS}$	$V_{DS}=25\text{V}$ , $V_{GS}=0\text{V}$ , $f=1.0\text{MHz}$		600	780	pF
Output Capacitance	$C_{OSS}$			165	215	pF
Reverse Transfer Capacitance	$C_{RSS}$			32	40	pF
<b>SWITCHING PARAMETERS</b>						
Total Gate Charge	$Q_G$	$V_{DS}=80\text{V}$ , $I_D=19\text{A}$ , $V_{GS}=10\text{V}$ (Note 1, 2)		19	25	nC
Gate Source Charge	$Q_{GS}$			3.9		nC
Gate Drain Charge	$Q_{GD}$			9.0		nC
Turn-ON Delay Time	$t_{D(ON)}$	$V_{DD}=50\text{V}$ , $I_D=19\text{A}$ , $R_G=25\Omega$ (Note 1, 2)		7.5	25	ns
Turn-ON Rise Time	$t_R$			150	310	ns
Turn-OFF Delay Time	$t_{D(OFF)}$			20	50	ns
Turn-OFF Fall-Time	$t_F$			65	140	ns

■ ELECTRICAL CHARACTERISTICS (Cont.)

PARAMETER	SYMBOL	TEST CONDITIONS	MIN	TYP	MAX	UNIT
<b>SOURCE- DRAIN DIODE RATINGS AND CHARACTERISTICS</b>						
Diode Forward Voltage	$V_{SD}$	$V_{GS}=0V, I_S=15.6A$			1.5	V
Maximum Body-Diode Continuous Current	$I_S$				15.6	A
Maximum Pulsed Drain-Source Diode Forward Current	$I_{SM}$				62.4	A
Body Diode Reverse Recovery Time	$t_{RR}$	$V_{GS}=0V, I_S=19A,$		78		ns
Body Diode Reverse Recovery Charge	$Q_{RR}$	$dI_F/dt=100A/\mu s$ (Note 1)		200		nC

Note: 1. Pulse Test : Pulse width  $\leq 300\mu s$ , Duty cycle  $\leq 2\%$

2. Essentially independent of operating temperature

■ TEST CIRCUITS AND WAVEFORMS

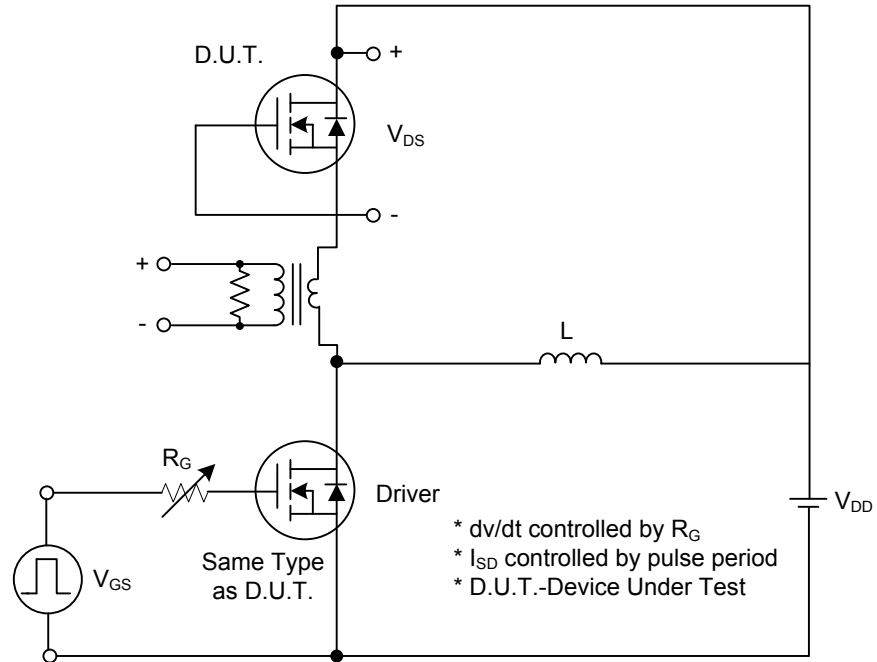

Fig. 1A Peak Diode Recovery dv/dt Test Circuit

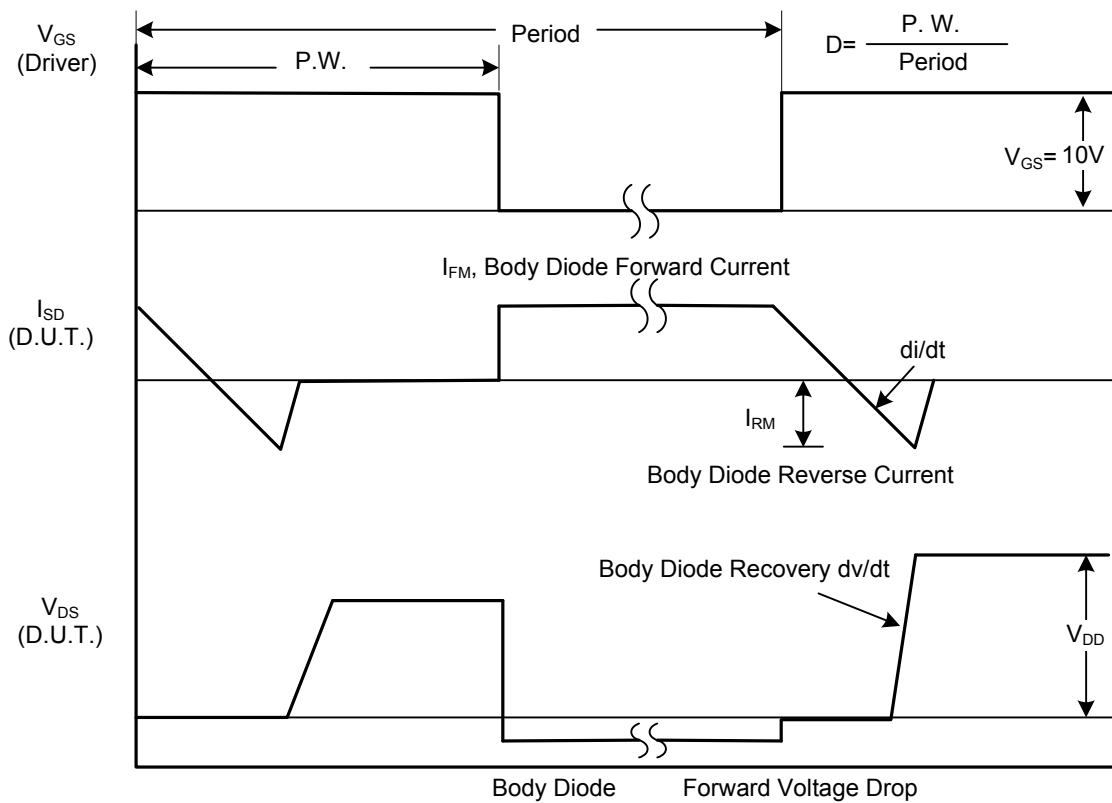

Fig. 1B Peak Diode Recovery dv/dt Waveforms

■ TEST CIRCUITS AND WAVEFORMS (Cont.)

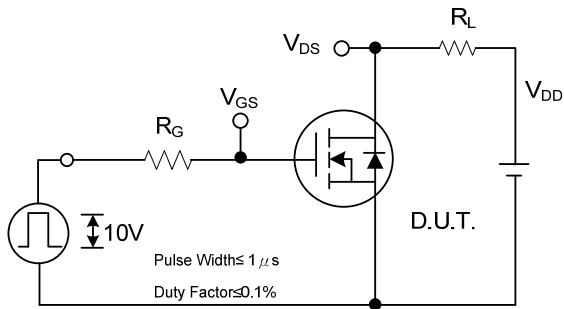

Fig. 2A Switching Test Circuit

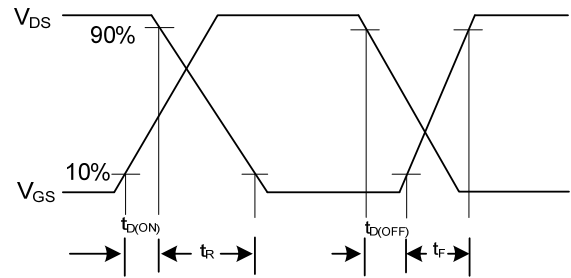

Fig. 2B Switching Waveforms

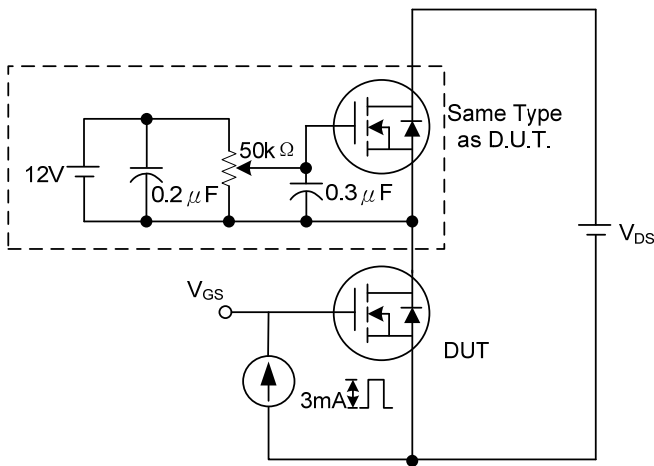

Fig. 3A Gate Charge Test Circuit

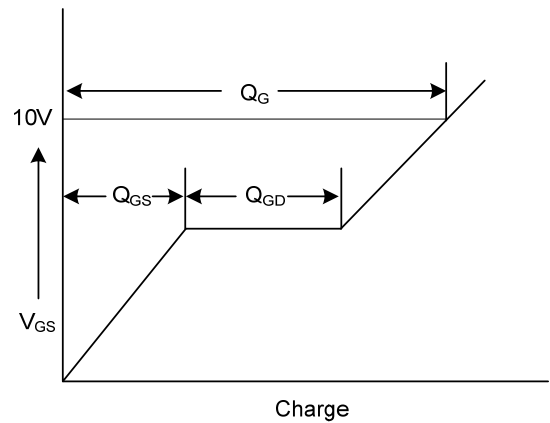

Fig. 3B Gate Charge Waveform

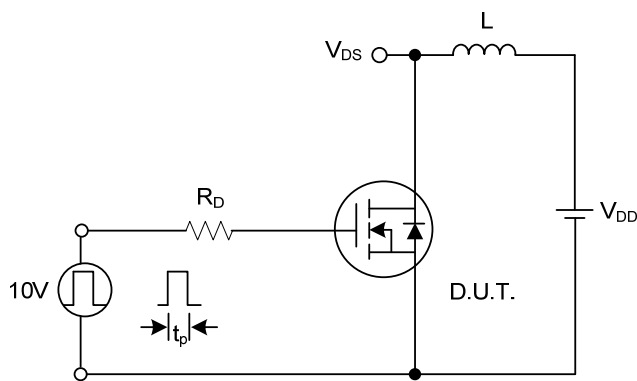

Fig. 4A Unclamped Inductive Switching Test Circuit

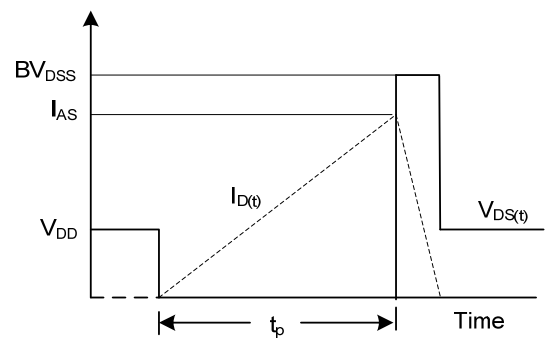

Fig. 4B Unclamped Inductive Switching Waveforms

UTC assumes no responsibility for equipment failures that result from using products at values that exceed, even momentarily, rated values (such as maximum ratings, operating condition ranges, or other parameters) listed in products specifications of any and all UTC products described or contained herein. UTC products are not designed for use in life support appliances, devices or systems where malfunction of these products can be reasonably expected to result in personal injury. Reproduction in whole or in part is prohibited without the prior written consent of the copyright owner. The information presented in this document does not form part of any quotation or contract, is believed to be accurate and reliable and may be changed without notice.