

Photo IC diode assembly S10108, S10109

For flame eye/using photo IC diode (RoHS compliance) instead of CdS cell



S10108 and S10109 sensors are designed specifically for flame detection (flame eye) in oil-fired hot water boilers and heaters. These sensors incorporate a photo IC diode instead of conventional CdS cells and are available with 2 types of incident light direction (head-on type S10108; and side-on type: S10109). Each sensor is assembled in an easy-to-install package along with the cable.

Features

- Spectral response suitable for detecting oil burner
- Easy-to-install assembly with cable
- Little variation in output current and good linearity (in comparison with conventional types using phototransistors and CdS cells)
- RoHS compliant products

Applications

- Flame detection in oil boilers and heaters
- Safety devices and alarms for heat generating devices
- Photorelay control devices

■ Absolute maximum ratings (Ta=25 °C)

Parameter	Symbol	Value	Unit
Maximum reverse voltage	VR Max.	-0.5 to +16	V
Photocurrent	IL	10	mA
Forward current	IF	10	mA
Power dissipation *1	P	250	mW
Operating temperature	Topr	-30 to +80	°C
Storage temperature	Tstg	-40 to +85	°C

*1: Derate power dissipation at a rate of -3.3 mW/°C above Ta=25 °C

■ Electrical and optical characteristics (Ta=25 °C)

Parameter	Symbol	Condition	Min.	Typ.	Max.	Unit
Spectral response range	λ		-	300 to 820	-	nm
Peak sensitivity wavelength	λ_p		-	560	-	nm
Dark current	ID	VR=5 V	-	1.0	50	nA
Photocurrent	IL	VR=5 V, 100 lx	0.19	0.31	0.48	mA
Rise time *2	tr	10 to 90 %, VR=7.5 V RL=10 k Ω , λ =560 nm	-	6.0	-	ms
Fall time *2	tf	90 to 10 %, VR=7.5 V RL=10 k Ω , λ =560 nm	-	2.5	-	ms

*2: Rise/fall time measurement method

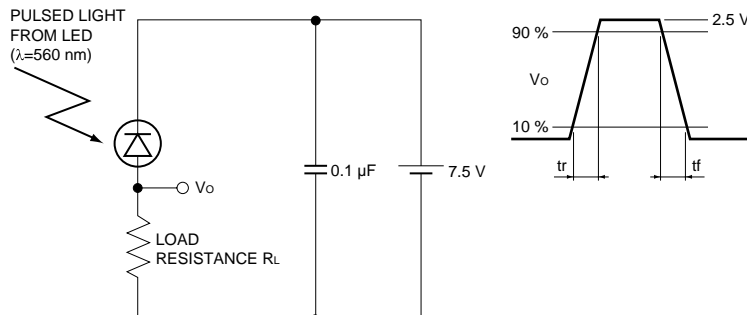

KPIC0041EA

■ Spectral response

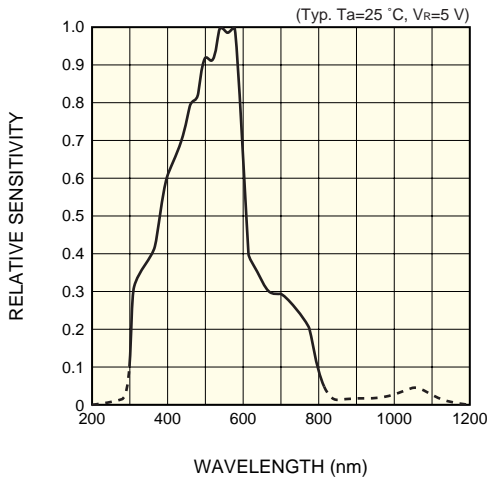

KPICB0101EA

■ Linearity

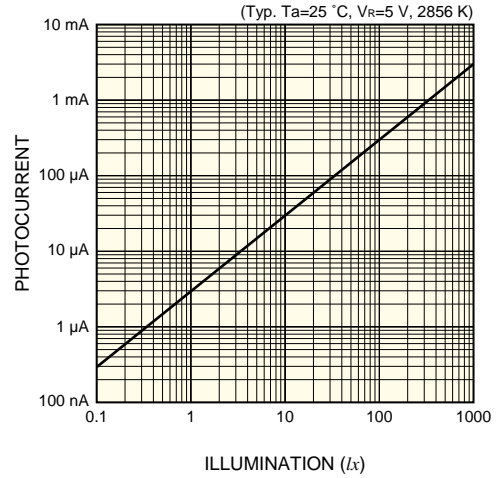

KPICB0102EA

■ Rise/fall times vs. load resistance

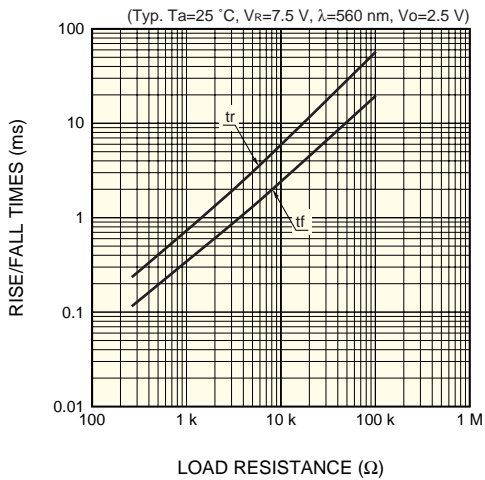

KPICB0077EA

■ Operating circuit examples

Example ①

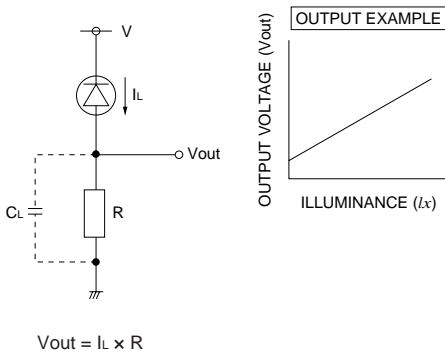

KPICC0125EA

Example ②

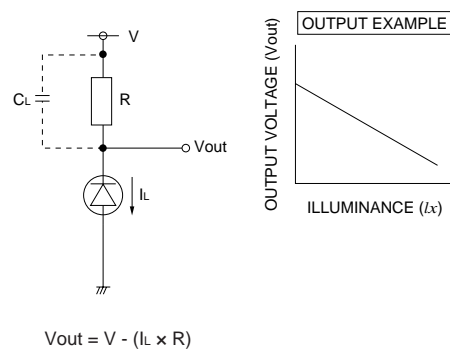

KPICC0126EA

Note)

- The photo IC diode has a specific polarity (anode/cathode). Be careful to make the correct connection.
- The photo IC diode must be reverse-biased so that a positive potential is applied to the cathode.
- Set load resistance R by taking the latter circuit into account.
- To eliminate high-frequency components, we recommend placing a load capacitance CL in parallel with load resistance RL as a low-pass filter.

$$\text{Cut-off frequency } f_c \cong \frac{1}{2\pi C_L R_L}$$

- Before using, check whether noise is present in the location where this product is used. Take measures to prevent noise as needed, for example, by shielding the cable or adding a capacitor (about 0.1 μF between the anode and cathode of the photo IC diode).

■ Dimensional outlines (unit: mm)

S10108 (head-on type)

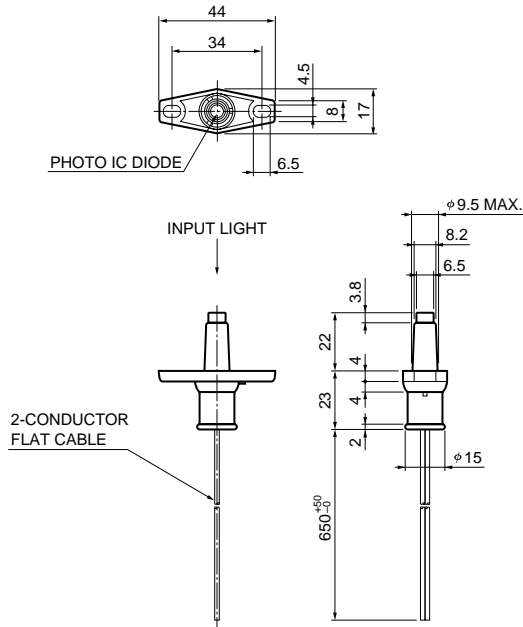

KPICA0068EA

S10109 (side-on type)

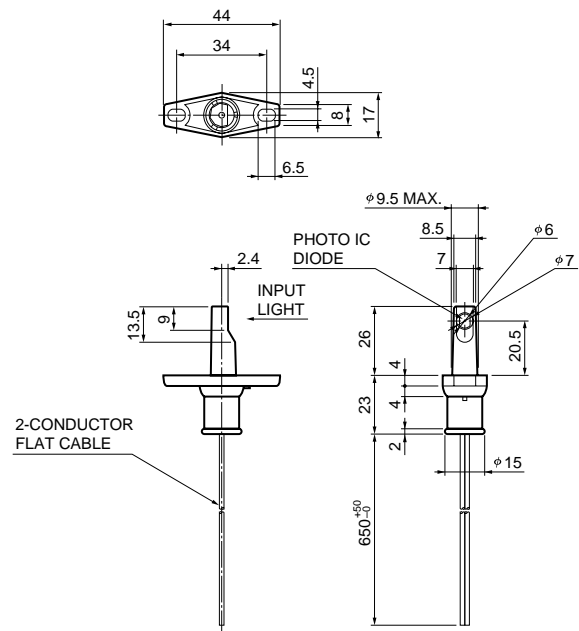

KPICA0069EA

2-conductor flat cable

Color	Conductor cross-section area	Dimension	Pin connection
White	0.3 mm ²	φ1.6 mm	Anode
With red line	0.3 mm ²	φ1.6 mm	Cathode

These products have a shape designed for specific use in flame detection applications. Before using, however, please test these products in actual equipment to ensure their characteristics and reliability.