

MF1511-03

S1D15714 Series

NOTICE

No part of this material may be reproduced or duplicated in any form or by any means without the written permission of Seiko Epson. Seiko Epson reserves the right to make changes to this material without notices. Seiko Epson does not assume any liability of any kind arising out of any inaccuracies contained in this material or due to its application or use in any product or circuit and, further, there is no representation that this material is applicable to products requiring high level reliability, such as, medical products. Moreover, no license to any intellectual property rights is granted by implication or otherwise, and there is no representation or warranty that anything made in accordance with this material will be free from any patent or copyright infringement of a third party. This material or portions thereof may contain technology or the subject relating to strategic products under the control of the Foreign Exchange and Foreign Trade Law of Japan and may require an export license from the Ministry of International Trade and Industry or other approval from another government agency.

All other product names mentioned herein are trademarks and/or registered trademarks of their respective companies.

Contents

1. DESCRIPTION	1
2. FEATURES	1
3. BLOCK DIAGRAM	2
4. PIN ASSIGNMENT	3
5. PIN DESCRIPTION	7
6. FUNCTIONAL DESCRIPTION	11
7. COMMAND	26
8. ABSOLUTE MAXIMUM RATINGS	45
9. DC CHARACTERISTICS	46
10. TIMING CHARACTERISTICS	53
11. MPU INTERFACE	58
12. CONNECTION BETWEEN LCD DRIVERS	59
13. LCD PANEL WIRING	60
14. CAUTIONS	61

1. DESCRIPTION

The S1D15714 Series is a single chip MLS driver for dot matrix liquid crystal displays which can be directly connected to the microcomputer bus. It accepts the 8-bit parallel or serial display data from the microcomputer to store the data in the on-chip display data RAM, and issues liquid crystal drive signals independently of the microcomputer.

The S1D15714 Series incorporates a display data RAM (65 × 168 bits), 1 bit of the on-chip RAM respond to one-dot pixels.

The S1D15714 Series features 65 common output circuits and 168 segment output circuits. A single chip provides a display of 10 characters by 4 lines with 65 × 168 dots (16 × 16 dots) and display of 14 characters by 5 lines by the 12 × 12 dot-character font.

The S1D15714 Series incorporates the analog temperature sensor circuit that changes output voltage depending on ambient temperature and can be used to constitute a system to provide optimum LCD contrast throughout a wide temperature range without need for use of supplementary parts such as the thermistor, under controls of a micro computer.

Display data RAM read/write operations do not require operation clock from outside, thereby ensuring operation with the minimum current consumption. Furthermore, it incorporates a LCD-drive power supply characterized by low power consumption and a CR oscillator circuit for display clock; therefore, the display system of a handy and high-performance instrument can be realized by use of the minimum current consumption and minimum chip configuration.

2. FEATURES

- Direct RAM data display by display data RAM
Normally white display is in normal mode
RAM bit data
“1” : On and black
“0” : Off and white
- RAM capacity
65 × 168 = 10,920 bits
- Liquid crystal drive circuit
65 common outputs and 168 segment outputs
- High-speed 8-bit MPU interface (directly connectable to the MPUs of both 80/68 series) /serial interface possible
- A variety of command functions
n-line reversal, display data RAM address control, display ON/OFF, display normal/reverse rotation, display all lighting ON/OFF, liquid crystal drive power supply circuit control, display clock built-in oscillator circuit control
- MLS drive technology
Built-in high precision voltage regulation function
- High precision CR oscillator circuit incorporated
- Low power consumption
- Built-in temperature sensor circuit
- Power supply
Logic power supply 1: VDI – VSS = 2.7 V to 3.3 V
Logic power supply 2: VDD – VSS = 2.7 V to 5.5 V
Liquid crystal drive power supply: V3 – VSS = 5.6 to 16.2 V
Boosting power supply: VDD2 – VSS = VDD to 5.5 V
- Wide operation temperature range: –40 to 85°C
- CMOS process
- Shipping form : Bare chips
- Light and radiation proof measures are not taken in designing.

Series specifications

Product name	Form of shipping	Chip thickness
S1D15714D00B000	Bare chip	0.625mm

3. BLOCK DIAGRAM

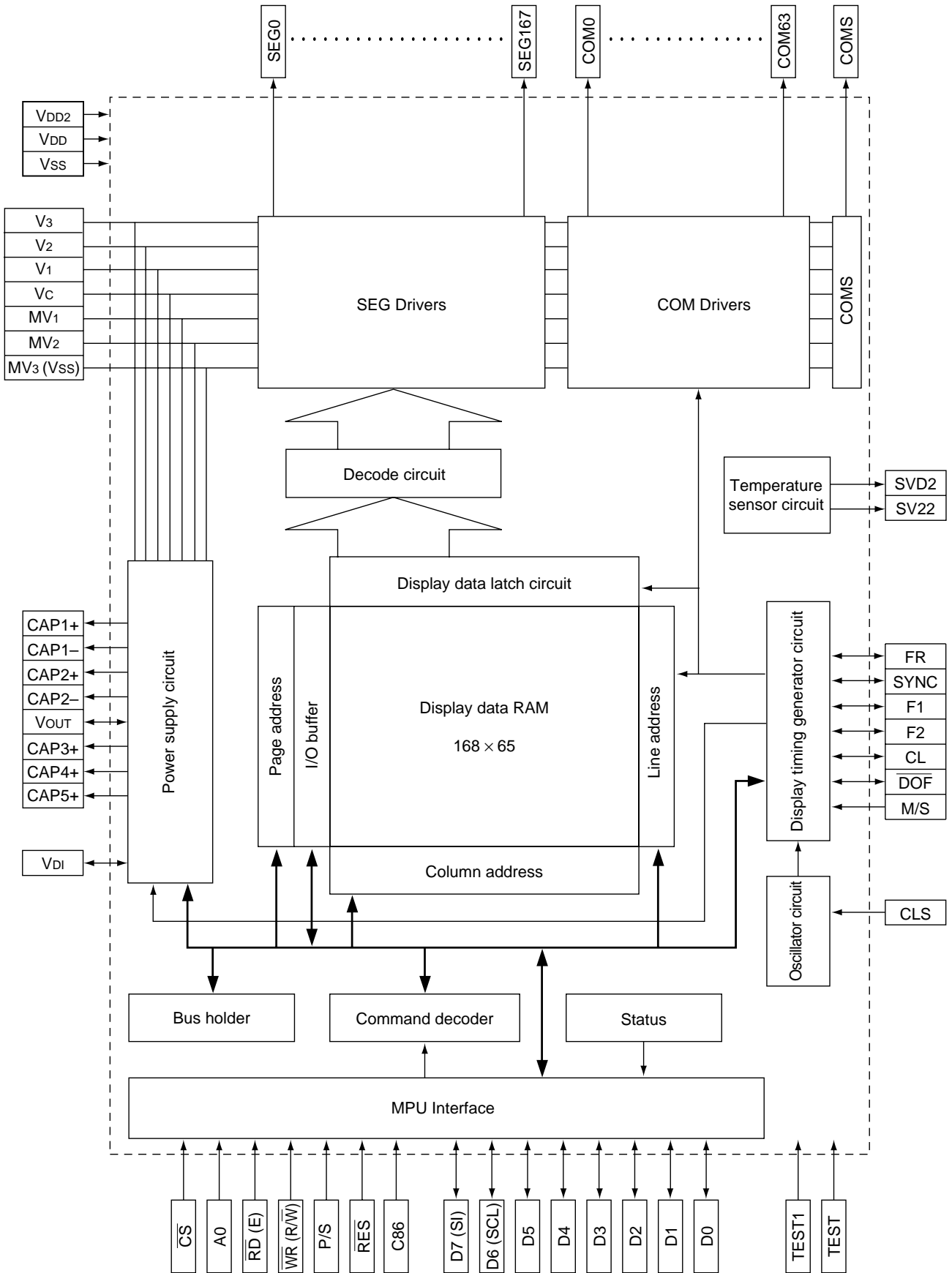

4. PIN ASSIGNMENT

4.1 Chip Assignment

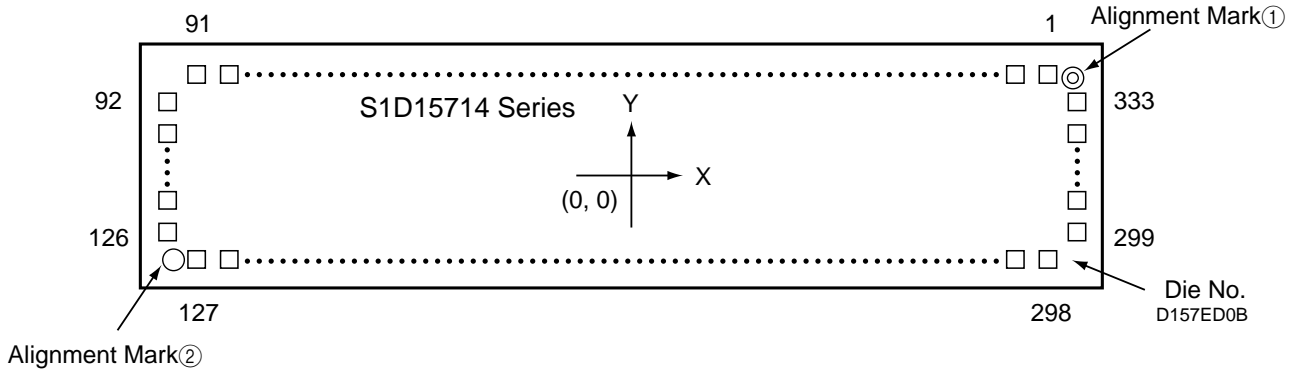

Item	Size		Unit
	X	Y	
Chip size	11.20 × 2.27		mm
Chip thickness	0.625		mm
Bump pitch	51 (Min.)		μm
Bump size	PAD No.1, 2, 13, 16, 29, 91	36 × 84	μm
	PAD No.3 to 12, 14, 15, 17 to 28, 30 to 90	81 × 84	μm
	PAD No.92 to 126, 299 to 333	85 × 34	μm
	PAD No.127 to 298	42 × 85	μm
Bump height	17 (Typ.)		μm

4.2 Alignment mark

Alignment coordinate

① (5364, 975) μm

② (-5415, -942) μm

Mark size

a = 70.5 μm

b = 20.3 μm

c = 79.5 μm

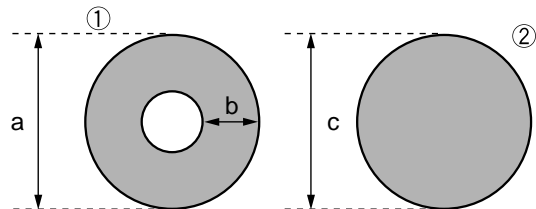

4.3 Pad Center Coordinates

Unit: μm

PAD No.	Pin Name	X	Y	PAD No.	Pin Name	X	Y	PAD No.	Pin Name	X	Y
1	NC	4986	982	51	CAP1+	-728	982	101	COM23	-5449	463
2	VDD	4935		52	CAP1+	-835		102	COM22		412
3	TEST1	4856		53	CAP1-	-941		103	COM21		361
4	SYNC	4750		54	CAP1-	-1048		104	COM20		310
5	FR	4643		55	CAP1-	-1154		105	COM19		259
6	CL	4537		56	CAP3+	-1261		106	COM18		208
7	DOF	4430		57	CAP3+	-1367		107	COM17		157
8	F1	4324		58	CAP3+	-1474		108	COM16		106
9	F2	4217		59	CAP5+	-1580		109	COM15		55
10	CS	4111		60	CAP5+	-1687		110	COM14		4
11	RES	4004		61	CAP5+	-1793		111	COM13		-47
12	A0	3898		62	VOUT	-1900		112	COM12		-98
13	Vss	3819		63	CAP4+	-2006		113	COM11		-149
14	WR,R/W	3740		64	CAP4+	-2113		114	COM10		-200
15	RD,E	3634		65	CAP4+	-2219		115	COM9		-251
16	VDD	3555		66	CAP2-	-2326		116	COM8		-302
17	D0	3476		67	CAP2-	-2432		117	COM7		-353
18	D1	3370		68	CAP2-	-2539		118	COM6		-404
19	D2	3263		69	CAP2+	-2645		119	COM5		-455
20	D3	3157		70	CAP2+	-2752		120	COM4		-506
21	D4	3050		71	CAP2+	-2858		121	COM3		-557
22	D5	2944		72	V3	-2965		122	COM2		-608
23	D6, SCL	2837		73	V3	-3071		123	COM1		-659
24	D6, SCL	2731		74	V2	-3178		124	COM0		-710
25	D7, SI	2624		75	V2	-3284		125	COMS		-761
26	D7, SI	2518		76	V1	-3391		126	NC		-812
27	VDI	2411		77	V1	-3497		127	NC	-5130	-982
28	VDI	2305		78	Vc	-3604		128	NC	-5070	
29	VDD	2226		79	Vc	-3710		129	SEG0	-5010	
30	M/S	2147		80	MV1	-3817		130	SEG1	-4950	
31	CLS	2041		81	MV1	-3923		131	SEG2	-4890	
32	Vss	1934		82	MV2	-4030		132	SEG3	-4830	
33	Vss	1828		83	MV2	-4136		133	SEG4	-4770	
34	Vss	1721		84	Vss	-4243		134	SEG5	-4710	
35	Vss	1615		85	Vss	-4349		135	SEG6	-4650	
36	TEST	1508		86	Vss	-4456		136	SEG7	-4590	
37	C86	1402		87	VDD	-4562		137	SEG8	-4530	
38	P/S	1295		88	NC	-4669		138	SEG9	-4470	
39	VDD	1189		89	SVD2	-4775		139	SEG10	-4410	
40	VDD	1082		90	SV22	-4882		140	SEG11	-4350	
41	VDD	976		91	NC	-4961		141	SEG12	-4290	
42	VDD	869		92	NC	-5449	922	142	SEG13	-4230	
43	VDD2	763		93	COM31		871	143	SEG14	-4170	
44	VDD2	656		94	COM30		820	144	SEG15	-4110	
45	VDD2	550		95	COM29		769	145	SEG16	-4050	
46	VDD2	443		96	COM28		718	146	SEG17	-3990	
47	VOUT	-302		97	COM27		667	147	SEG18	-3930	
48	VOUT	-409		98	COM26		616	148	SEG19	-3870	
49	VOUT	-515		99	COM25		565	149	SEG20	-3810	
50	CAP1+	-622		100	COM24		514	150	SEG21	-3750	

Unit: μm

PAD No.	Pin Name	X	Y	PAD No.	Pin Name	X	Y	PAD No.	Pin Name	X	Y
151	SEG22	-3690	-982	201	SEG72	-690	-982	251	SEG122	2310	-982
152	SEG23	-3630		202	SEG73	-630		252	SEG123	2370	
153	SEG24	-3570		203	SEG74	-570		253	SEG124	2430	
154	SEG25	-3510		204	SEG75	-510		254	SEG125	2490	
155	SEG26	-3450		205	SEG76	-450		255	SEG126	2550	
156	SEG27	-3390		206	SEG77	-390		256	SEG127	2610	
157	SEG28	-3330		207	SEG78	-330		257	SEG128	2670	
158	SEG29	-3270		208	SEG79	-270		258	SEG129	2730	
159	SEG30	-3210		209	SEG80	-210		259	SEG130	2790	
160	SEG31	-3150		210	SEG81	-150		260	SEG131	2850	
161	SEG32	-3090		211	SEG82	-90		261	SEG132	2910	
162	SEG33	-3030		212	SEG83	-30		262	SEG133	2970	
163	SEG34	-2970		213	SEG84	30		263	SEG134	3030	
164	SEG35	-2910		214	SEG85	90		264	SEG135	3090	
165	SEG36	-2850		215	SEG86	150		265	SEG136	3150	
166	SEG37	-2790		216	SEG87	210		266	SEG137	3210	
167	SEG38	-2730		217	SEG88	270		267	SEG138	3270	
168	SEG39	-2670		218	SEG89	330		268	SEG139	3330	
169	SEG40	-2610		219	SEG90	390		269	SEG140	3390	
170	SEG41	-2550		220	SEG91	450		270	SEG141	3450	
171	SEG42	-2490		221	SEG92	510		271	SEG142	3510	
172	SEG43	-2430		222	SEG93	570		272	SEG143	3570	
173	SEG44	-2370		223	SEG94	630		273	SEG144	3630	
174	SEG45	-2310		224	SEG95	690		274	SEG145	3690	
175	SEG46	-2250		225	SEG96	750		275	SEG146	3750	
176	SEG47	-2190		226	SEG97	810		276	SEG147	3810	
177	SEG48	-2130		227	SEG98	870		277	SEG148	3870	
178	SEG49	-2070		228	SEG99	930		278	SEG149	3930	
179	SEG50	-2010		229	SEG100	990		279	SEG150	3990	
180	SEG51	-1950		230	SEG101	1050		280	SEG151	4050	
181	SEG52	-1890		231	SEG102	1110		281	SEG152	4110	
182	SEG53	-1830		232	SEG103	1170		282	SEG153	4170	
183	SEG54	-1770		233	SEG104	1230		283	SEG154	4230	
184	SEG55	-1710		234	SEG105	1290		284	SEG155	4290	
185	SEG56	-1650		235	SEG106	1350		285	SEG156	4350	
186	SEG57	-1590		236	SEG107	1410		286	SEG157	4410	
187	SEG58	-1530		237	SEG108	1470		287	SEG158	4470	
188	SEG59	-1470		238	SEG109	1530		288	SEG159	4530	
189	SEG60	-1410		239	SEG110	1590		289	SEG160	4590	
190	SEG61	-1350		240	SEG111	1650		290	SEG161	4650	
191	SEG62	-1290		241	SEG112	1710		291	SEG162	4710	
192	SEG63	-1230		242	SEG113	1770		292	SEG163	4770	
193	SEG64	-1170		243	SEG114	1830		293	SEG164	4830	
194	SEG65	-1110		244	SEG115	1890		294	SEG165	4890	
195	SEG66	-1050		245	SEG116	1950		295	SEG166	4950	
196	SEG67	-990		246	SEG117	2010		296	SEG167	5010	
197	SEG68	-930		247	SEG118	2070		297	NC	5070	
198	SEG69	-870		248	SEG119	2130		298	NC	5130	
199	SEG70	-810		249	SEG120	2190		299	NC	5449	-812
200	SEG71	-750		250	SEG121	2250		300	COM32		-761

S1D15714 Series

Unit: μm

PAD No.	Pin Name	X	Y
301	COM33	5449	-710
302	COM34		-659
303	COM35		-608
304	COM36		-557
305	COM37		-506
306	COM38		-455
307	COM39		-404
308	COM40		-353
309	COM41		-302
310	COM42		-251
311	COM43		-200
312	COM44		-149
313	COM45		-98
314	COM46		-47
315	COM47		4
316	COM48		55
317	COM49		106
318	COM50		157
319	COM51		208
320	COM52		259
321	COM53		310
322	COM54		361
323	COM55		412
324	COM56		463
325	COM57		514
326	COM58		565
327	COM59		616
328	COM60		667
329	COM61		718
330	COM62		769
331	COM63		820
332	COMS		871
333	NC		922

5. PIN DESCRIPTION

5.1 Power Pin

Pin name	I/O	Description	Number of pins																				
VDD	Power supply	Connect to system MPU power supply pin Vcc.	8																				
VSS	Power supply	Connect to the system GND. MV3 is short circuited with MV3 inside the IC chip.	8																				
VDD2	Power supply	Boosting power supply circuit. It is necessary to maintain the co-relation between the VDD2 and VDD as: $VDD2 \geq VDD$.	4																				
VDI	Power supply	This is the power supply pin for operating internal circuits that are generated from VDD. Connect a capacitor for stabilizing voltage between VDI and VSS. VDI can be used for external inputs as well. In case of external input, make TEST1 = LOW and use this pin in the ranges of $3.3V \geq VDI \geq 2.7V$ and $VDD \geq VDI$. When using it in the range of $VDD = 2.7$ to $3.3V$, make TEST1 = LOW and short-circuit this pin to VDD.	2																				
V3, V2, V1, Vc, MV1, MV2	Power supply	A liquid crystal drive multi-level power supply. The voltages determined by the liquid crystal cell are impedance-converted by resistive divider and operational amplifier for application. The following order must be maintained: $V3 \geq V2 \geq V1 \geq Vc \geq MV1 \geq MV2 \geq MV3 (=Vss)$ MV3 is short circuited with MV3 inside the IC chip. Master operation: When power supply is turned on, the following voltage is applied to each pin by the built-in power supply circuit. The voltage is selected by Bias Change Command. <table border="1" style="margin-left: auto; margin-right: auto;"> <tbody> <tr> <td>V2</td> <td>$6/8 \cdot V3$</td> <td>$16/20 \cdot V3$</td> <td>$14/16 \cdot V3$</td> </tr> <tr> <td>V1</td> <td>$5/8 \cdot V3$</td> <td>$13/20 \cdot V3$</td> <td>$11/16 \cdot V3$</td> </tr> <tr> <td>Vc</td> <td>$4/8 \cdot V3$</td> <td>$10/20 \cdot V3$</td> <td>$8/16 \cdot V3$</td> </tr> <tr> <td>MV1</td> <td>$3/8 \cdot V3$</td> <td>$7/20 \cdot V3$</td> <td>$5/16 \cdot V3$</td> </tr> <tr> <td>MV2</td> <td>$2/8 \cdot V3$</td> <td>$4/20 \cdot V3$</td> <td>$2/16 \cdot V3$</td> </tr> </tbody> </table>	V2	$6/8 \cdot V3$	$16/20 \cdot V3$	$14/16 \cdot V3$	V1	$5/8 \cdot V3$	$13/20 \cdot V3$	$11/16 \cdot V3$	Vc	$4/8 \cdot V3$	$10/20 \cdot V3$	$8/16 \cdot V3$	MV1	$3/8 \cdot V3$	$7/20 \cdot V3$	$5/16 \cdot V3$	MV2	$2/8 \cdot V3$	$4/20 \cdot V3$	$2/16 \cdot V3$	12 (2 each)
V2	$6/8 \cdot V3$	$16/20 \cdot V3$	$14/16 \cdot V3$																				
V1	$5/8 \cdot V3$	$13/20 \cdot V3$	$11/16 \cdot V3$																				
Vc	$4/8 \cdot V3$	$10/20 \cdot V3$	$8/16 \cdot V3$																				
MV1	$3/8 \cdot V3$	$7/20 \cdot V3$	$5/16 \cdot V3$																				
MV2	$2/8 \cdot V3$	$4/20 \cdot V3$	$2/16 \cdot V3$																				

5.2 LCD Power Supply Circuit Pin

Pin name	I/O	Description	Number of pins
CAP1+	O	Pin connected to the positive side of the step-up capacitor. Connect the capacitor between this pin and CAP1- pin.	3
CAP1-	O	Pin connected to the negative side of the step-up capacitor. Connect the capacitor between this pin and CAP1+ pin.	3
CAP2+	O	Pin connected to the positive side of the step-up capacitor. Connect the capacitor between this pin and CAP2- pin.	3
CAP2-	O	Pin connected to the negative side of the step-up capacitor. Connect the capacitor between this pin and CAP2+ pin.	3
VOUT	I/O	Output pin for step-up. Connect the capacitor between this pin and VDD or VDD2. When VOUT is used with external voltage, this pin can be a input terminal.	4
CAP3+	O	Pin connected to the positive side of the step-up capacitor. Connect the capacitor between this pin and CAP2- pin.	3
CAP4+	O	Pin connected to the positive side of the step-up capacitor. Connect the capacitor between this pin and CAP1- pin.	3
CAP5+	O	Pin short circuited with VOUT terminal. When VOUT is used with external voltage, this pin can be left OPEN.	3

5.3 System Bus Connection Pin

Pin name	I/O	Description	Number of pins																		
D7 to D0 (SI) (SCL)	I/O	Connects to the 8-bit or 16-bit MPU data bus via the 8-bit bi-directional data bus. When the serial interface is selected (P/S = LOW and C86 = LOW), D7 serves as the serial data input (SI) and D6 serves as the serial clock input (SCL), In this case, D0 through D5 go to a high impedance state. When the Chip select is inactive, D0 through D7 go to a high impedance state.	10																		
A0	I	Normally, the least significant bit MPU address bus is connected to distinguish between data and command. A0 = HIGH : indicates that D0 to D7 are display data or command parameters. A0 = LOW : indicates that D0 to D7 are control commands.	1																		
\overline{RES}	I	When the \overline{RES} is LOW, initialization is achieved. Resetting operation is done on the level of the RES signal.	1																		
\overline{CS}	I	A chip select signal. When \overline{CS} = LOW, signals are active, and data/command input/output are enabled.	1																		
\overline{RD} (E)	I	<ul style="list-style-type: none"> When the 80 series MPU is connected. "Active" "LOW" A pin for connection of the \overline{RD} signal of the 80 series MPU. When this signal is LOW, the data bus of the S1D15714 Series is in the output state. When the 68 series MPU is connected. "Active" "HIGH" Serves as a 68 series MPU enable clock input pin. 	1																		
\overline{WR} (R/W)	I	<ul style="list-style-type: none"> When the 80 series MPU is connected. "Active" "LOW" A pin for connection of the \overline{WR} signal of the 80 series MPU. Signals on the data bus are latched at the leading edge of the \overline{WR} signal. Serves as a read/write control signal input pin when the 68 series MPU is connected. R/W = HIGH : Read R/W = LOW : Write 	1																		
C86	I	A MPU interface switching pin. C86 = HIGH : 68 series MPU interface C86 = LOW : 80 series MPU interface (Serial Interface)	1																		
P/S	I	<p>Parallel data input/serial data input select pin P/S = HIGH : Parallel data input P/S = LOW : Serial data input P/S = LOW and C86 = LOW : Serial interface spec P/S = LOW and C86 = HIGH : Please do not set up The following Table shows the summary:</p> <table border="1" style="width: 100%; border-collapse: collapse;"> <thead> <tr> <th>P/S</th> <th>C86</th> <th>Data/Command</th> <th>Data</th> <th>Read/Write clock</th> <th>Serial</th> </tr> </thead> <tbody> <tr> <td>HIGH</td> <td>LOW</td> <td>A0</td> <td>D0 to D7</td> <td>\overline{RD}, \overline{WR}</td> <td></td> </tr> <tr> <td>LOW</td> <td>LOW</td> <td>A0</td> <td>SI (D7)</td> <td>Write only</td> <td>SCL (D6)</td> </tr> </tbody> </table> <p>When P/S = LOW, D0 to D5 are high impedance. D0 to D5 can be HIGH, LOW or open. \overline{RD}(E) and \overline{WR}(R/W) are locked to HIGH or LOW. The serial data input does not allow the RAM display data to be read.</p>	P/S	C86	Data/Command	Data	Read/Write clock	Serial	HIGH	LOW	A0	D0 to D7	\overline{RD} , \overline{WR}		LOW	LOW	A0	SI (D7)	Write only	SCL (D6)	1
P/S	C86	Data/Command	Data	Read/Write clock	Serial																
HIGH	LOW	A0	D0 to D7	\overline{RD} , \overline{WR}																	
LOW	LOW	A0	SI (D7)	Write only	SCL (D6)																

Pin name	I/O	Description	Number of pins																		
CLS	I	<p>A pin used to select Enable/Disable state of the built-in oscillator circuit for display clock.</p> <p>CLS = HIGH : Built-in oscillator circuit Enabled CLS = LOW : Built-in oscillator circuit Disabled (External input)</p> <p>When CLS is LOW, display clock is input from the CL pin. When the S1D15714 Series is used in the master/slave mode, each CLS pins must be set to the same level.</p> <table border="1"> <thead> <tr> <th>Display clock</th> <th>Master</th> <th>Slave</th> </tr> </thead> <tbody> <tr> <td>Built-in oscillator circuit used</td> <td>HIGH</td> <td>HIGH</td> </tr> <tr> <td>External input</td> <td>LOW</td> <td>LOW</td> </tr> </tbody> </table>	Display clock	Master	Slave	Built-in oscillator circuit used	HIGH	HIGH	External input	LOW	LOW	1									
Display clock	Master	Slave																			
Built-in oscillator circuit used	HIGH	HIGH																			
External input	LOW	LOW																			
M/S	I	<p>A pin used to select the master/slave operation for S1D15714 Series.</p> <p>Liquid crystal display system is synchronized when the master operation outputs the timing signal required for liquid crystal display, while the slave operation inputs the timing signal required for liquid crystal display.</p> <p>M/S = HIGH : Master operation M/S = LOW : Slave operation</p> <p>The following Table shows the relation in conformance to the M/S and CLS:</p> <table border="1"> <thead> <tr> <th>M/S</th> <th>CLS</th> <th>Oscillation circuit</th> <th>Power circuit</th> <th>CL</th> <th>FR, $\overline{\text{DOF}}$, F1, F2, SYNC</th> </tr> </thead> <tbody> <tr> <td>HIGH</td> <td>HIGH LOW</td> <td>Enabled Disabled</td> <td>Enabled Enabled</td> <td>Output Input</td> <td>Output Output</td> </tr> <tr> <td>LOW</td> <td>HIGH LOW</td> <td>Disabled Disabled</td> <td>Disabled Disabled</td> <td>Input Input</td> <td>Input Input</td> </tr> </tbody> </table>	M/S	CLS	Oscillation circuit	Power circuit	CL	FR, $\overline{\text{DOF}}$, F1, F2, SYNC	HIGH	HIGH LOW	Enabled Disabled	Enabled Enabled	Output Input	Output Output	LOW	HIGH LOW	Disabled Disabled	Disabled Disabled	Input Input	Input Input	1
M/S	CLS	Oscillation circuit	Power circuit	CL	FR, $\overline{\text{DOF}}$, F1, F2, SYNC																
HIGH	HIGH LOW	Enabled Disabled	Enabled Enabled	Output Input	Output Output																
LOW	HIGH LOW	Disabled Disabled	Disabled Disabled	Input Input	Input Input																
CL	I/O	<p>Display clock input/output pin.</p> <p>The following Table shows the relation in conformance to the M/S and CLS state:</p> <table border="1"> <thead> <tr> <th>M/S</th> <th>CLS</th> <th>CL</th> </tr> </thead> <tbody> <tr> <td>HIGH</td> <td>HIGH LOW</td> <td>Output Input</td> </tr> <tr> <td>LOW</td> <td>HIGH LOW</td> <td>Input Input</td> </tr> </tbody> </table> <p>When you want to use the S1D15714 Series in the master/slave mode, connect each CL pin.</p>	M/S	CLS	CL	HIGH	HIGH LOW	Output Input	LOW	HIGH LOW	Input Input	1									
M/S	CLS	CL																			
HIGH	HIGH LOW	Output Input																			
LOW	HIGH LOW	Input Input																			
FR	I/O	<p>A liquid crystal alternating current input/output pin.</p> <p>M/S = HIGH : Output M/S = LOW : Input</p> <p>When you want to use the S1D15714 Series in the master/slave mode, connect each FR pin.</p>	1																		
F1, F2, SYNC	I/O	<p>A liquid crystal sync signal input/output pin.</p> <p>M/S = HIGH : Output M/S = LOW : Input</p> <p>When you want to use the S1D15714 Series in the master/slave mode, connect each F1, F2 and SYNC pins.</p>	3 (1 each)																		
$\overline{\text{DOF}}$	I/O	<p>A liquid crystal blanking control pin.</p> <p>M/S = HIGH : Output M/S = LOW : Input</p> <p>When you want to use the S1D15714 Series in the master/slave mode, connect each $\overline{\text{DOF}}$ pin.</p>	1																		

5.4 Liquid crystal drive pin

Pin name	I/O	Description	Number of pins
SEG0 to SEG167	O	Liquid crystal segment drive output pins. One of the V ₂ , V ₁ , V _C , MV ₁ , and MV ₂ levels is selected by a combination of the display RAM content and FR/F1/F2 signals.	168
COM0 to COM63	O	Liquid crystal common drive output pins. One of the V ₃ , V _C , MV ₃ (V _{SS}) levels is selected by a combination of the scan data and FR/F1/F2 signals.	64
COMS	O	COM output pins for indicator. These pins outputted the same signal. Set to OPEN not used. When COMS is used for the master/ slave configuration, the same signal is output to both the master and slave.	2

5.5 Temperature Sensor Pins

Pin name	I/O	Description	Number of pins
SVD2	O	This is analog voltage output pin for the temperature sensor.	1
SV22	O	This is test pin for the temperature sensor. Fix the pin OPEN.	1

5.6 Test pins

Pin name	I/O	Description	Number of pins
TEST	I	IC chip test pin. Fix the pin LOW.	1
TEST1	I	<p>V_{DI} generation circuit control pin. When using this pin in the range of V_{DD} = 3.3 to 5.5V, fix this pin to HIGH. When using this pin in the range of V_{DD} = 2.7 to 3.3V, fix this to LOW and short-circuit V_{DD} to V_{DI}.</p> <p>When this pin is used after TEST1 is switched from LOW to HIGH, the initialization to make Reset RES = LOW is required after TEST1 is switched to HIGH.</p> <p>The V_{DI} generation circuit operates independently from power saving. To reduce the current consumption close to the static current with the power saving function while this pin is used in the range of V_{DD} = 3.3 to 5.5V, make it possible to switch TEST1 to LOW during power saving.</p>	1

6. FUNCTIONAL DESCRIPTION

6.1 MPU Interface

6.1.1 Selection of Interface Type

S1D15714 Series allows data to be sent via the 8-bit bi-directional data buses (D7 to D0) or serial data input (SI). By setting the polarity of the P/S pin and C86 pin to HIGH or LOW, you can select either 8-bit parallel data input or serial data input, as shown in Table 6.1.

Table 6.1

P/S	C86		$\overline{\text{CS}}$	A0	$\overline{\text{RD}}$	$\overline{\text{WR}}$	D7	D6	D5 to D0
HIGH	—	Parallel input	$\overline{\text{CS}}$	A0	$\overline{\text{RD}}$	$\overline{\text{WR}}$	D7	D6	D5 to D0
LOW	LOW	Serial input	$\overline{\text{CS}}$	A0	—	—	SI	SCL	(HZ)

—: Fixed to HIGH or LOW HZ: High impedance state

6.1.2 Parallel interface

When the parallel interface is selected (P/S = HIGH), direction connection to the MPU bus of either 80 series MPU or 68 series MPU is performed by setting the 86 pin to either HIGH or LOW, as shown in Table 6.2.

Table 6.2

P/S	$\overline{\text{CS}}$	A0	$\overline{\text{RD}}$	$\overline{\text{WR}}$	D7 to D0
HIGH : 68 series MPU bus	$\overline{\text{CS}}$	A0	E	R/ $\overline{\text{W}}$	D7 to D0
LOW : 80 series MPU bus	$\overline{\text{CS}}$	A0	$\overline{\text{RD}}$	$\overline{\text{WR}}$	D7 to D0

The data bus signals are identified by a combination of A0, $\overline{\text{RD}}$ (E), and $\overline{\text{WR}}$ (R/ $\overline{\text{W}}$) signals as shown in Table 6.3.

Table 6.3

Common	68 series	80 series		Function
	R/ $\overline{\text{W}}$	$\overline{\text{RD}}$	$\overline{\text{WR}}$	
A0				
1	1	0	1	Display data read, status read
1	0	1	0	Display data write, Command parameter write
0	0	1	0	Command write

6.1.3 Serial interface

When the serial interface is selected (P/S = LOW and C86 = LOW), the chip is active ($\overline{\text{CS}}$ = LOW and C86 = LOW), and reception of serial data input (SI) and serial clock input (SCL) is enabled. Serial interface comprises a 8-bit shift register and 3-bit counter. The serial data are latched by the rising edge of serial clock signals in the order of D7, D6, ... and D0 starting from the serial data input pin. On the rising edge of 8th serial clock signal, they are converted into 8-bit parallel data to be processed.

Whether serial data input is a display data or command is identified by A0 input. A0 = HIGH indicates display data, while A0 = LOW shows command data. The A0 input is read and identified at every $8 \times n$ -th rising edge of the serial clock after the chip has turned active.

Fig. 6.1 shows the serial interface signal chart.

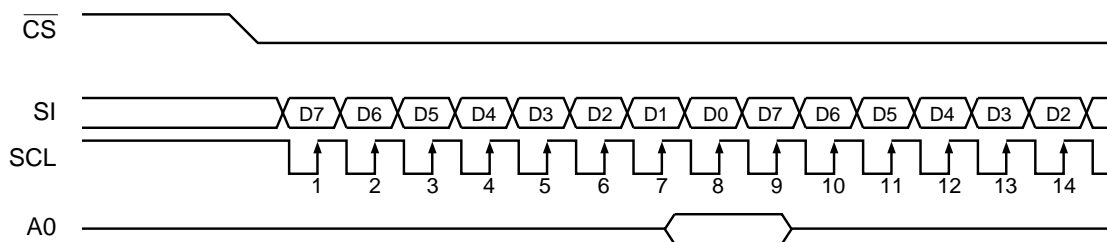

Fig. 6.1

- * When the chip is inactive, the counter is reset to the initials state.
- * Reading is not performed in the case of serial interface.
- * For the SCL signal, a sufficient care must be taken against terminal reflection of the wiring and external noise. Recommend to use an actual equipment to verify the operation.

6.1.4 Chip Selection

The S1D15714 Series has chip select pin. MPU interface or serial interface is enabled only when $\overline{CS} = \text{LOW}$. When the chip select pin is inactive, D0 to D5 are in the state of high impedance, while A0, RD and WR inputs are disabled. When serial interface is selected, the shift register and counter are reset.

6.1.5 Access to display data RAM and internal register

Access to S1D15714 Series series viewed from the MPU side is enabled only if the cycle time requirements are kept. This does not required waiting time; hence, high-speed data transfer is allowed. Furthermore, at the time of data transfer with the MPU, S1D15714 Series provides a kind of inter-LSI pipe line processing via the bus holder accompanying the internal data bus. For example, when data is written to the display data RAM by the MPU, the data is once held by the bus holder. It is written to the display data RAM before the next data write cycle comes. On the other hand, when the MPU reads the content of the display data RAM, it is read in the first data read cycle (dummy), and the data is held in the bus holder. Then it is read onto on the system bus from the bus holder in the next data read cycle. Restrictions are imposed on the display data RAM read sequence. When the address has been set, specified address data is not output to the Read command immediately after that. The specified address data is output in the second data reading. This must be carefully noted. Therefore, one dummy read operation is mandatory subsequent to address setting or write cycle. Fig. 6.2 illustrates this relationship.

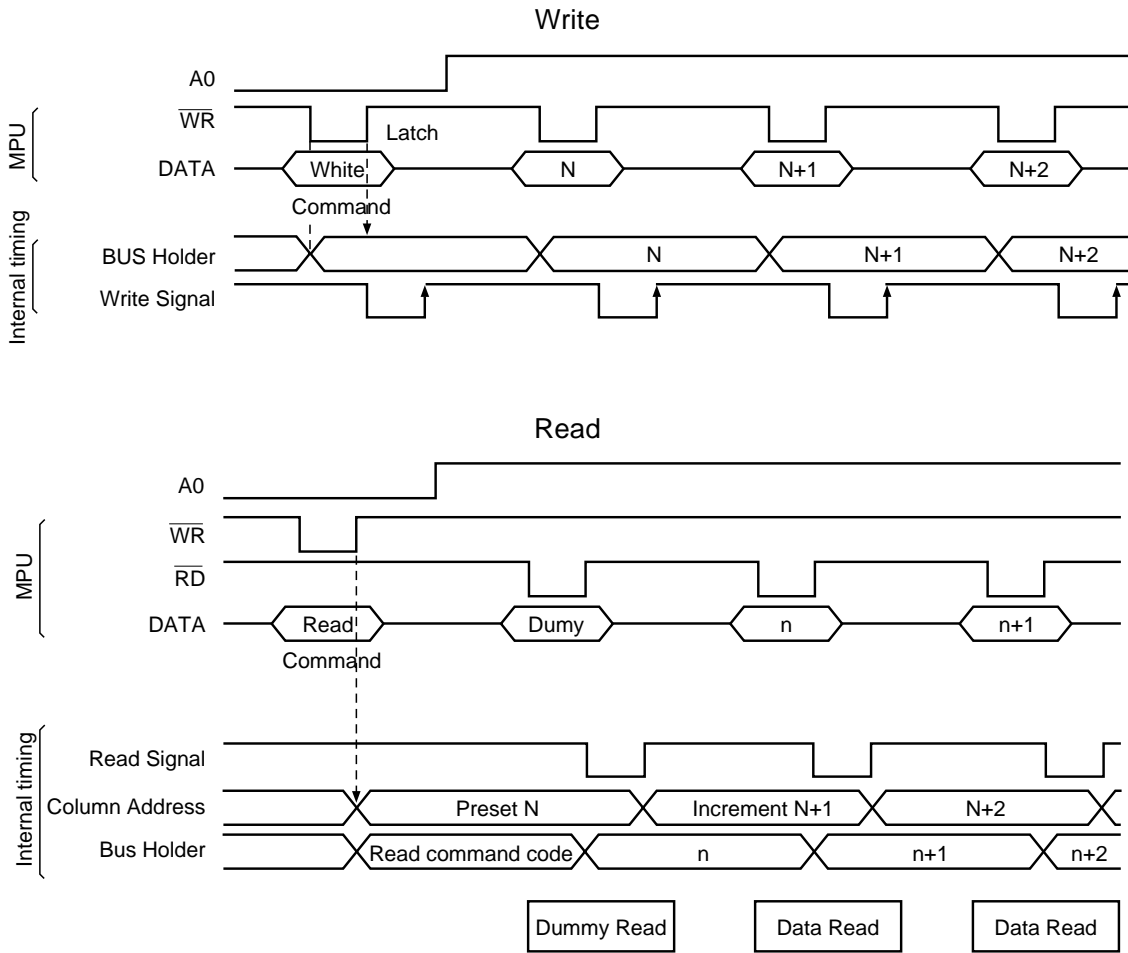

Fig. 6.2

6.2 Display data RAM

6.2.1 Display Data RAM

This is a RAM to store the display dot data, and comprises 65×168 bits. Access to the desired bit is enabled by specifying the page address and column address.

The RAM 1 bit built in the one-dot pixel responds to it. When the RAM bit data is "1", the display is black. If it is "0", the display is given in white.

RAM bit data

- "1" : Light On Black (when display is in normal mode)
- "0" : Light Off White (when display is in normal mode)

Display data D7 to D0 from the MPU correspond to LCD common direction, as shown in Fig. 6.3 and 6.4. Therefore, less restrictions when multi-chip usage.

Furthermore, read/write operations from the MPU to the RAM are carried out via the input/output buffer. The read operation from Display data RAM is designed as an independent operation. Accordingly, even if the MPU accesses the RAM asynchronously during LCD display, no adverse effect is given to display.

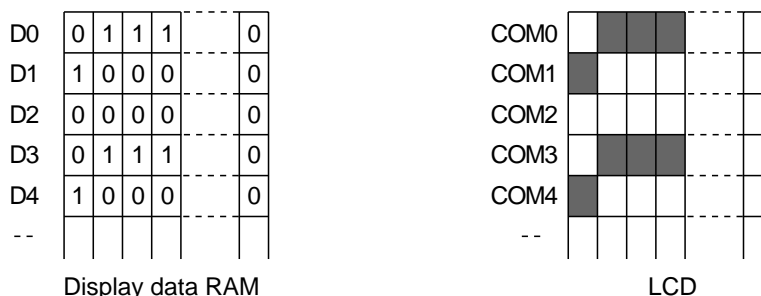

Fig. 6.3 Binary

6.2.2 Page address circuit/column address circuit

The address of the display data RAM to be accessed is specified by the Page Address Set command and Column Address Set command, as shown in Fig. 6.4.

For Address incremental direction, either the column direction or page direction can be selected by the Address Direction command. Whichever direction is chosen, increment is carried out by positive one (+1) after write or read operation.

When the column direction is selected for address increment, the column address is increased by +1 for every write or read operation. After the column address has accessed up to A7H, the page address is incremented by +1 and the column address shifts to 0H.

When the page direction is selected for address increment, the page address is increased with the column address locked in position. When the page address has accessed up to Page 8, the column address is incremented by +1, and the page address goes to Page 0.

Whichever direction is selected for address increment, the page address goes back to Page 0 and the column address to 0H after access up to the column address A7H of page address Page 8.

As shown in Fig. 6.4, relationship between the display data RAM column address and segment output can be reversed by the Column Address Set Direction command. This will reduce restrictions on IC layout during LCD module assembling.

Page 8 is a RAM domain only for indicators, only D0 of its display data is effective.

Table 6.4

SEG output	SEG0	SEG167
ADC "0"	0(H)→	Column Address →A7(H)
(D0) "1"	A7(H)←	Column Address ←0(H)

6.2.3 Line address circuit

The line address circuit specifies the line address corresponding to COM output when the contents of the display data RAM is displayed, as shown in Fig. 6.4. Normally, the top line of the display (COM0 output in the case of normal rotation of the common output status and COM63 output in the case of reverse rotation) is specified by the Display Start Line Address Set command. The display area starts from the specified display start line address to cover the area corresponding to the lines specified by the DUTY Set command in the direction where the line address increments. If the display start line address set command is used for dynamic modification of the line address, screen scroll and page change are enabled.

6.2.4 Display data latch circuit

The display data latch circuit is a latch to temporarily latch the display data output from then display data RAM to the liquid crystal drive circuit. Display normal/reverse, display ON/OFF, and display all lighting ON/OFF commands control the data in this latch, without the data in the display data RAM being controlled.

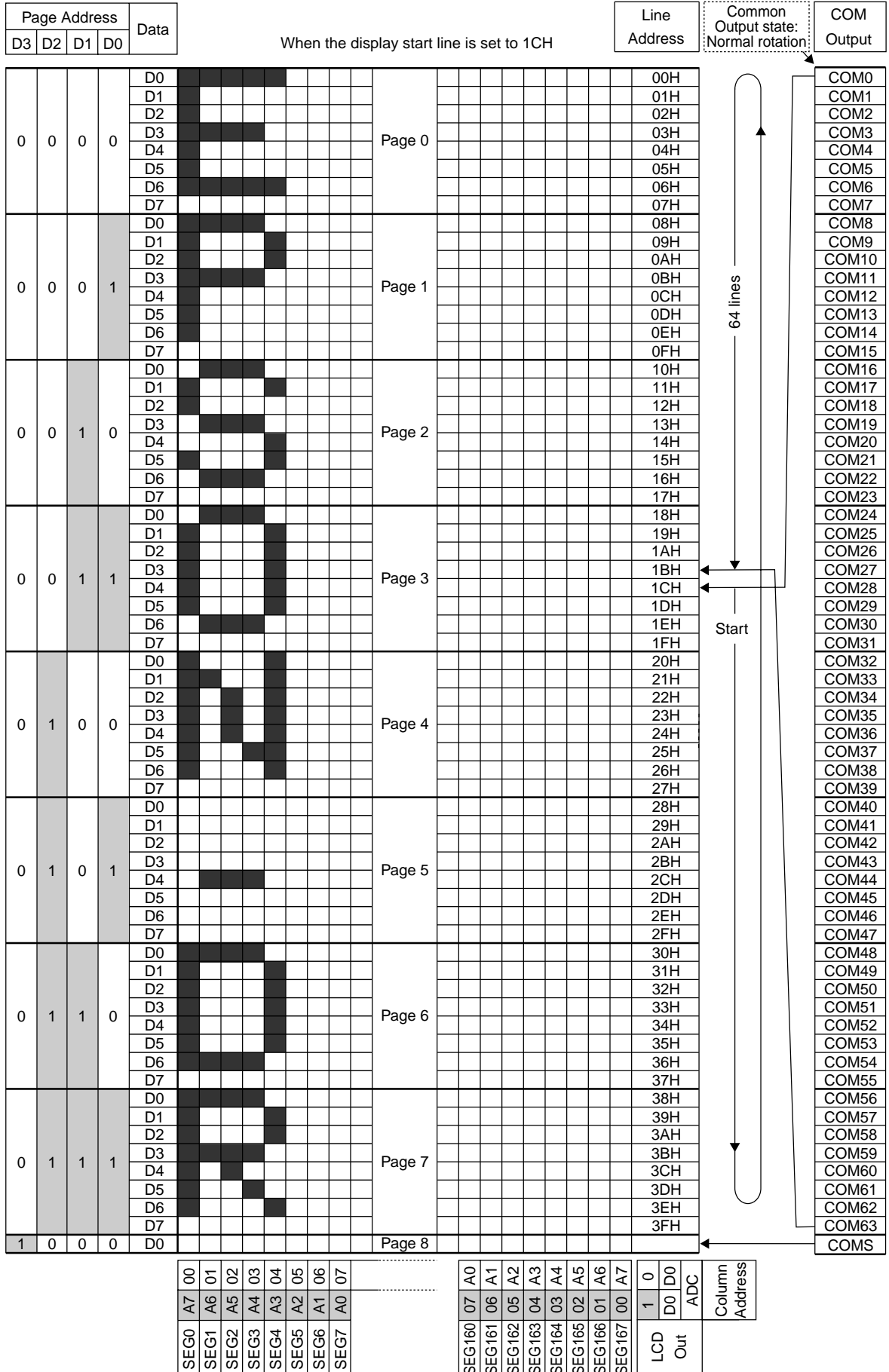

Fig. 6.4 Binary display

6.3 Oscillator circuit

A display clock is generated by the CR oscillator. The oscillator circuit is enabled only when M/S = HIGH and CLS = HIGH. Oscillation starts after input of the built-in oscillator circuit ON command input. When CLS = LOW, oscillation stops, and display clock is input from the CL pin.

6.4 Display timing generation circuit

Timing signals are generated from the display clock to the line address circuit and display data latch circuit. Synchronized with display clock, display data is latched in display data latch circuit, and is output to the segment drive output pin. Reading of the display data into the LCD drive circuit is completely independent of access from the MPU to the display data RAM. Accordingly, asynchronous access to the display data RAM during LCD display does not give any adverse effect; like as flicker.

Furthermore, the display clock generates internal common timing, liquid crystal alternating signal(FR), field start signal (SYNC) and drive pattern signal (F1 and F2).

The FR normally generates 2-frame alternating drive system drive waveform to the liquid crystal drive circuit. The n-line reverse alternating drive waveform is generated for each $4 \times (a+1)$ line by setting data on the n-line reverse drive register. When there is a display quality problem including crosstalk, the problem may be solved using the n-line reverse alternating drive.

Execute liquid crystal display to determine the number of lines “n” for alternation.

When you want to use the S1D15714 Series in multi-chip configuration, supply display timing signal (FR, SYNC, F1, F2, CL, DOF) to the slave side from the master side. Table 6.5 shows the statuses of FR, SYNC, F1, F2, CL, DOF.

Table 6.5

Operating mode		CL	FR, SYNC, F1, F2, DOF
Master (M/S = HIGH)	Built-in oscillator circuit enabled (CLS = HIGH)	Output	Output
	Built-in oscillator circuit disabled (CLS = LOW)	Input	Output
Slave (M/S = LOW)	Built-in oscillator circuit enabled (CLS = HIGH)	Input	Input
	Built-in oscillator circuit disabled (CLS = LOW)	Input	Input

6.5 Liquid crystal drive circuit

6.5.1 SEG Drivers

This is a SEG output circuit. It selects the five values of V2, V1, VC, MV1 and MV2 using the driver control signal determined by the decoder, and output them.

6.5.2 COM Drivers

This is a COM output circuit. It selects three values of V3, VC and MV3(VSS) using the driver control signal determined by the decoder, and output them.

S1D15714 Series allows the COM output scanning direction to be set by the common output status select command. (See Table 6.6). This will reduce restrictions on IC layout during LCD module assembling.

Table 6.6

Status	Direction of COM scanning		
Normal	COM 0	→	COM63
Reverse	COM63	→	COM 0

6.6 Power supply circuit

This is a power supply circuit to generate voltage required for liquid crystal drive, and is characterized by a low power consumption. It consists of a step-up circuit, voltage regulating circuit and liquid crystal drive voltage generating circuit, and is enabled only during master operation. The power supply circuit uses the power control set command to provide an on/off control of step-up circuit, voltage regulating circuit and liquid crystal drive potential generating circuit. This allows a combined use of the external power supply and part of built-in power supply functions. Table 6.7 shows functions controlled by the 3-bit data of the control set command, and Table 6.8 shows reference combinations. Also, by use of the magnification of amplification changing over command, it is possible to select the amplifying magnification from five different steps. The power supply circuit is enabled only during master operation.

Table 6.7 Respective Bit Control Contents by Power Control Set Command

Item	State	
	"1"	"0"
D2 Boosting circuit control bit	ON	OFF
D1 Voltage regulator circuit (V ₃ regulator circuit) control bit	ON	OFF
D0 LCD driving potential generating circuit (LCDV circuit) control bit	ON	OFF

Table 6.8 Reference combination

Circuits used	D2	D1	D0	Boosting circuit	Vc regulator circuit	LCDV circuit	Eternal input power supply
① Use of all built-in power supplies	1	1	1	○ "1"	○ "1"	○ "1"	—
② V ₃ regulating circuit and LCDV circuit only	0	1	1	× "0"	○ "1"	○ "1"	V _{OUT}
③ LCDV circuit only	0	0	1	× "0"	× "0"	○ "1"	V ₃
④ External power supply only	0	0	0	× "0"	× "0"	× "0"	V ₃ , V ₂ , V ₁ , V _C , MV ₁ , MV ₂

* Any combinations other than the above are not available.

The V₃ voltage is generated from V_{OUT}. To use the circuit as shown in ② in the above table, input the voltage, which makes $V_{OUT} \geq V_3 + 0.2V$, from the V_{OUT} pin.

6.6.1 Amplification circuit

By use of the amplification circuit being built into the S1D15714 Series, it is possible to make amplification of the electric potential between VDD2-VSS onto quintuple amplification, quadruple amplification, triple amplification or double amplification. Also, by use of the relevant command, it is possible to select either one from the quintuple amplification, quadruple amplification, triple amplification, double amplification and equal amplification.

- ① When using the quintuple-boosting, connect the capacitor C1 between CAP1+ <-> CAP1-, between CAP2+ <-> CAP2-, between CAP3+ <-> CAP1-, between CAP4+ <-> CAP2-, between VDD2 <-> VOUT and short-circuit the CAP5+, CAP4+ and VOUT pin before use.
- ② When using the quadruple-boosting, connect the capacitor C1 between CAP1+ <-> CAP1-, between CAP2+ <-> CAP2-, between CAP3+ <-> CAP1- and between VDD2 <-> VOUT and short-circuit the CAP5+, CAP4+ pin and the VOUT pin before use.
- ③ When using the triple-boosting, connect the capacitor C1 between CAP1+ <-> CAP1-, between CAP2+ <-> CAP2- and between VDD2 <-> VOUT and short-circuit the CAP5+, CAP4+ pin, CAP3+ pin and the VOUT pin before use.
- ④ When using the double-boosting, connect the capacitor C1 between CAP1+ <-> CAP1- and between VDD2 <-> VOUT, open the CAP2- pin and short-circuit the CAP5+, CAP4+ pin, CAP3+ pin, CAP2+ pin and the VOUT pin before use.

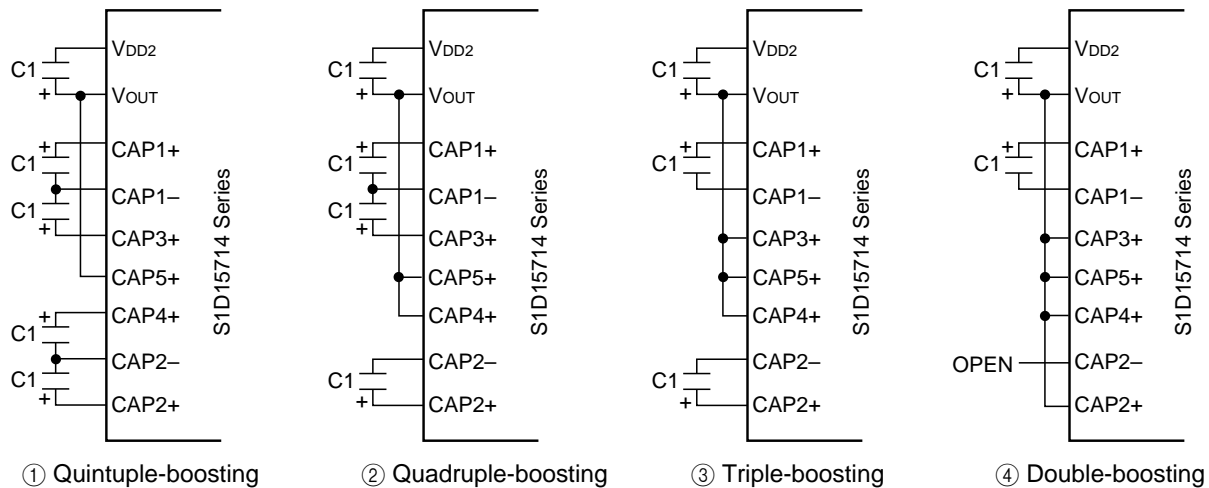

Fig. 6.5 below shows the electric potential relations when making respective amplifications.

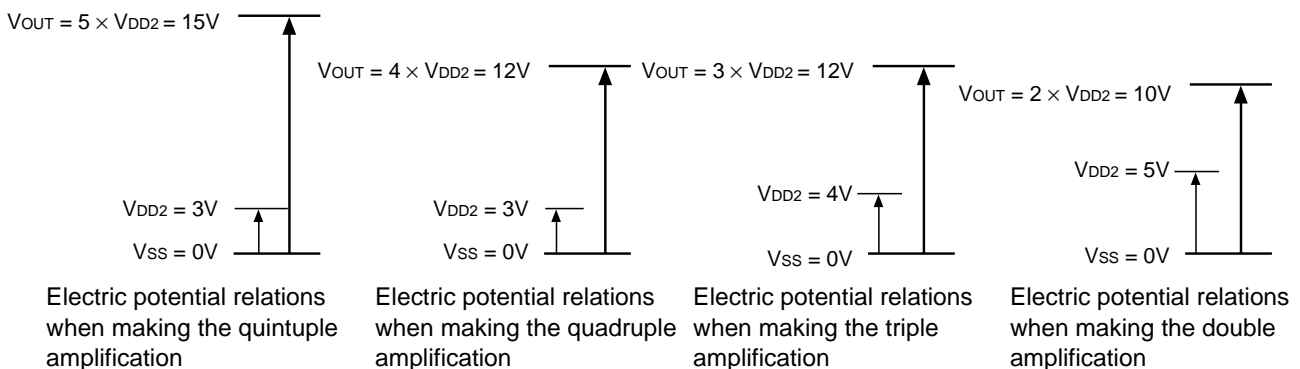

Fig. 6.5

* Set the voltage range of the VDD2 so that the voltage of the VOUT pin may not exceed the absolute maximum rating.

6.6.2 Voltage Regulating Circuit

V_{OUT} generated from the step-up circuit or V_{OUT} input from the outside produces liquid crystal drive voltage V_C via the voltage regulating circuit. The voltage regulating circuit is controlled by liquid crystal drive voltage change command and electronic volume.

The S1D15714 Series has a high precision constant voltage source, and incorporates 8-step liquid crystal drive voltage change command and 128-step electronic volume functions. This makes it possible to provide a high precision liquid crystal drive voltage regulation only by the command without adding any external parts.

- Electronic volume

α of Table 6.10 indicates an electronic volume command value. It takes one of 128 states when the data is set in the 7-bit electronic volume register.

Table 6.9 shows the value of α by setting the data in the electronic volume register.

Table 6.9

D6	D5	D4	D3	D2	D1	D0	α	V ₃ Voltage
0	0	0	0	0	0	0	0	Small ↑
0	0	0	0	0	0	1	1	
0	0	0	0	0	1	0	2	
1	1	1	1	1	0	1	125	↓ Large
1	1	1	1	1	1	0	126	
1	1	1	1	1	1	1	127	

- Liquid crystal drive voltage selection

The liquid drive voltage range can be selected from 8 states by the liquid crystal drive voltage select command using the 3-bit crystal drive voltage select command register. Table 6.10 shows V₃ voltage output ranges at 25°C.

Table 6.10

D2	D1	D0	V ₃ voltage output range
0	0	0	5.6 to 7.0V
0	0	1	6.3 to 7.8V
0	1	0	7.1 to 8.9V
0	1	1	8.0 to 10.0V
1	0	0	9.2 to 11.4V
1	0	1	10.3 to 12.8V
1	1	0	11.7 to 14.5V
1	1	1	12.8 to 16.0V

•V3 Output Voltage Value

Table 6.11 and Fig. 6.6 show logical values of V3 at 25°C. Regard the dispersion to logical values as ±3%.

Table 6.11

Unit [V]

LCD voltage selection			V3[V] ($\alpha = 0$ to 127)
D2	D1	D0	
0	0	0	$5.576+0.0109 \times \alpha$
0	0	1	$6.256+0.0122 \times \alpha$
0	1	0	$7.125+0.0139 \times \alpha$
0	1	1	$8.016+0.0156 \times \alpha$
1	0	0	$9.161+0.0178 \times \alpha$
1	0	1	$10.26+0.0200 \times \alpha$
1	1	0	$11.659+0.0227 \times \alpha$
1	1	1	$12.825+0.0250 \times \alpha$

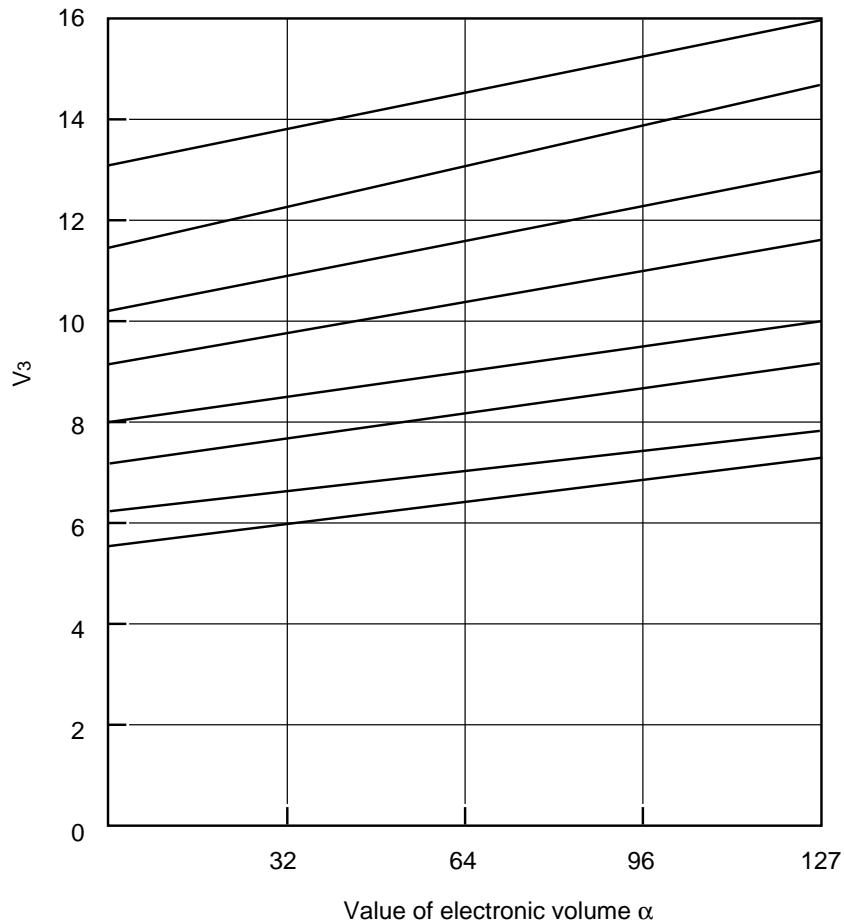

Fig. 6.6

6.6.3 Liquid crystal drive voltage generation circuit

Voltages V_3 is converted by resistive divider to produce V_2 , V_1 , V_C , MV_1 and MV_2 voltages. V_2 , V_1 , V_C , MV_1 and MV_2 voltages are impedance-converted by the voltage follower, and is supplied to the liquid crystal drive circuit. A bias ratio is chosen by the bias set command.

Table 6.12 LCD bias set command register contents

	Bias change command register value (D1, D0)		
	1/8 bias (0, 0)	1/6, 7 bias (0, 1)	1/5, 3 bias (1, 0)
V_2	$6/8 \cdot V_3$	$16/20 \cdot V_3$	$14/16 \cdot V_3$
V_1	$5/8 \cdot V_3$	$13/20 \cdot V_3$	$11/16 \cdot V_3$
V_C	$4/8 \cdot V_3$	$10/20 \cdot V_3$	$8/16 \cdot V_3$
MV_1	$3/8 \cdot V_3$	$7/20 \cdot V_3$	$5/16 \cdot V_3$
MV_2	$2/8 \cdot V_3$	$4/20 \cdot V_3$	$2/16 \cdot V_3$

6.6.4 Examples of the peripheral circuits of the power circuit

① When using all the built-in power supply
 When using the quintuple-boosting
 (C: 12 units VDD = VDI = 3.0 V)

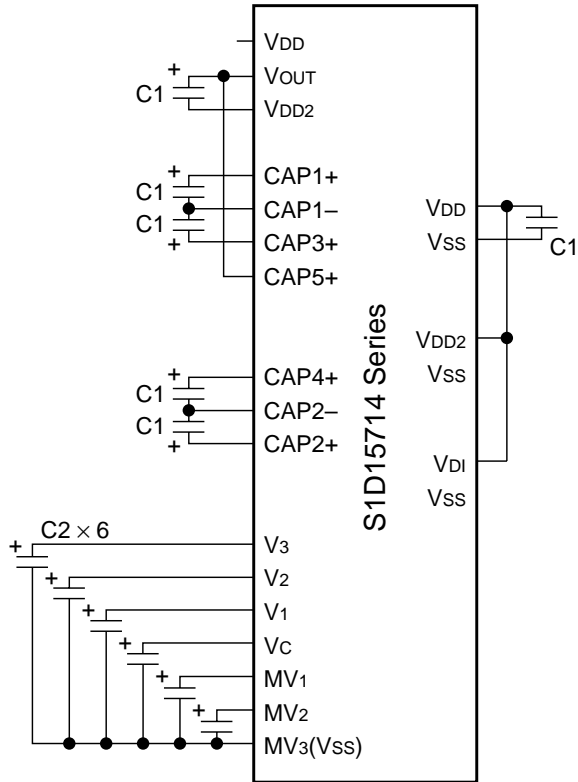

When using the quadruple-boosting (C: 13 units)

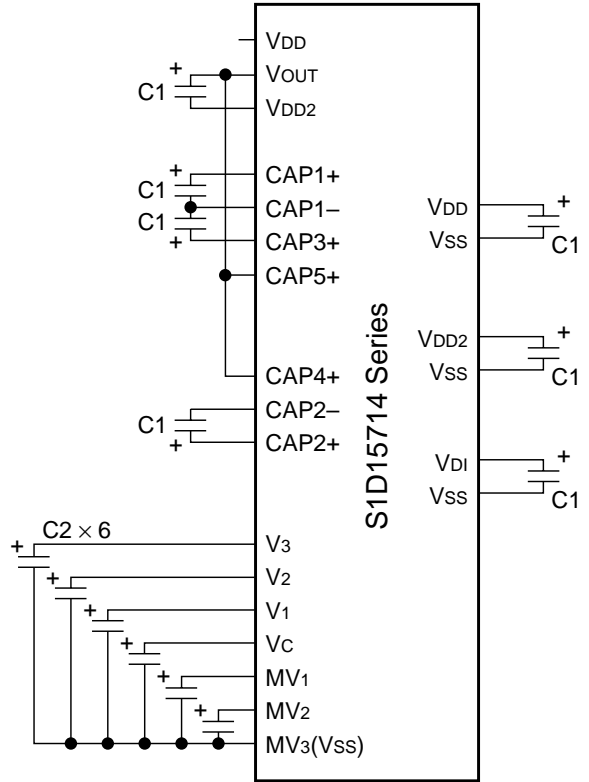

When using the triple-boosting (C: 12 units)

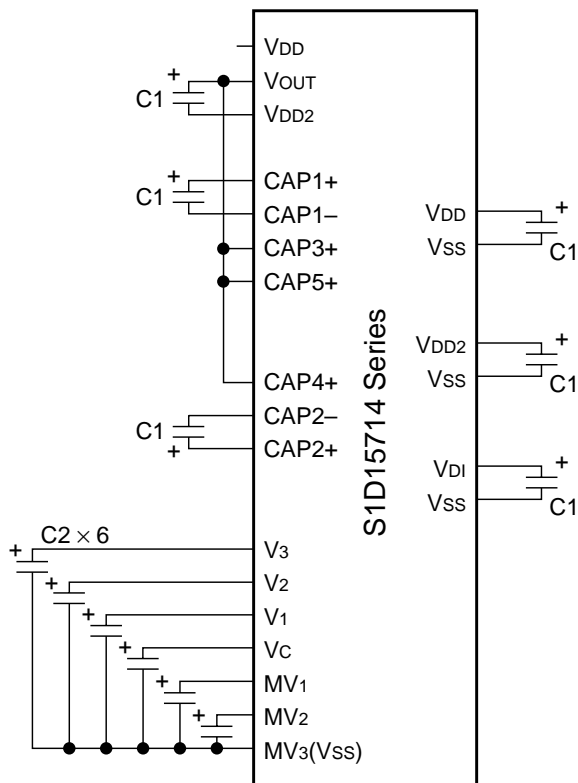

When using the double-boosting (C: 11 units)

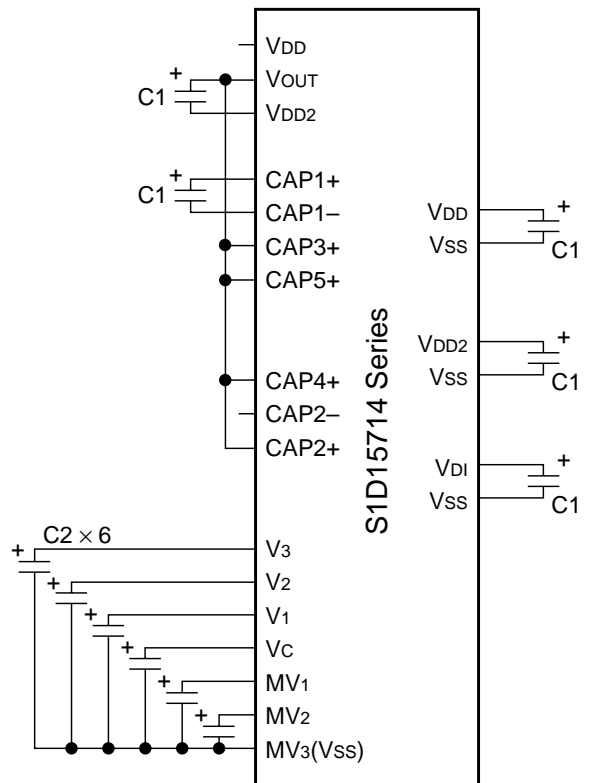

- ② V3 adjusting circuit and LCDV circuit
VOUT external input (C: 9 units)

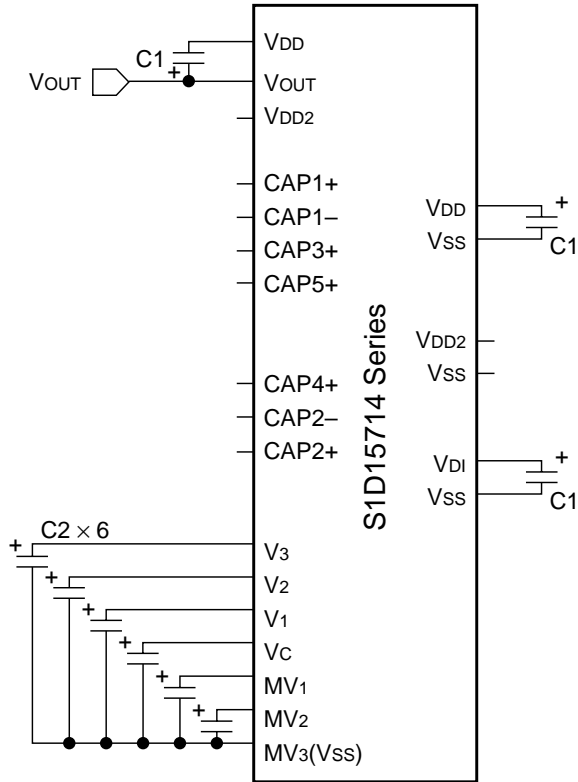

- ③ LCDV circuit only
V3 external input (C: 8 units)

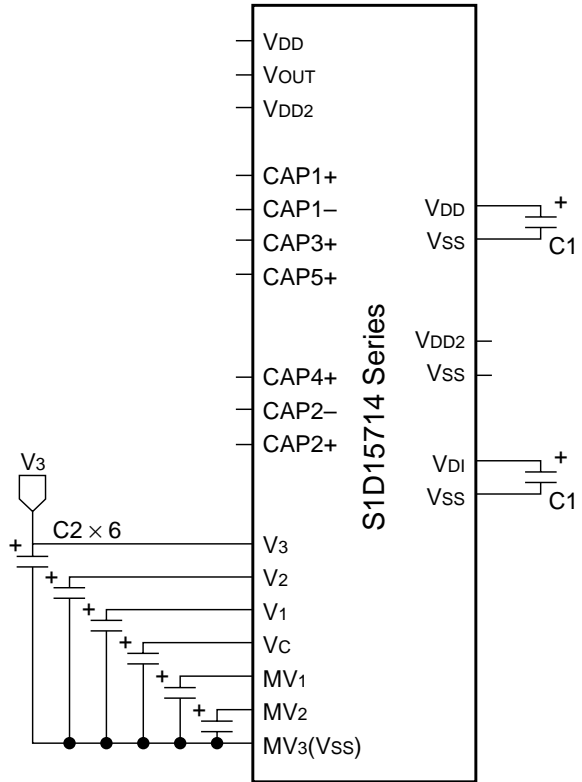

- ④ External power supply only
External input (C: 2 unit)

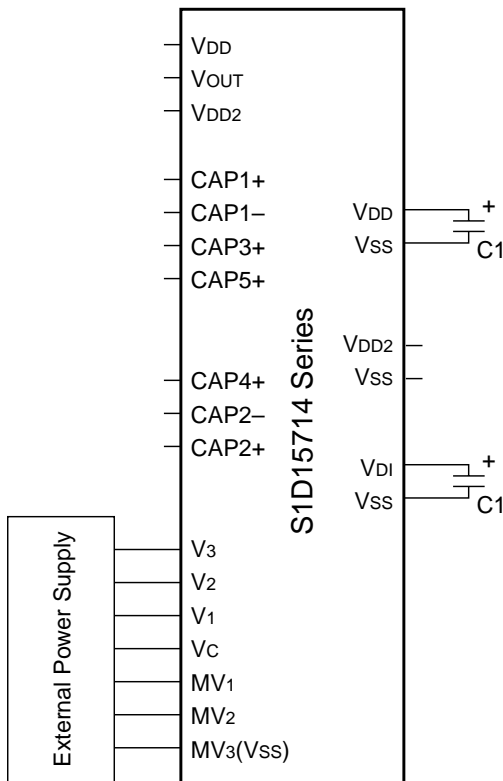

- ⑤ Connection Example of Smoothing Capacitor for Liquid Crystal Drive Voltage
In addition to the connections shown in the above ① to ③, the following connection is also possible.

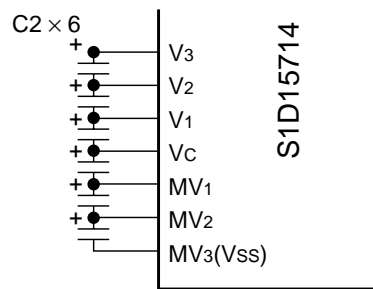

Examples of common reference settings		
Item	Settings	Unit
C1	1.0 to 4.7	μF
C2	0.1 to 1.0	

- *1 Optimum values of C1 and C2 above vary depending on the LCD panel to be driver. Above values should be referenced as information only. It is recommended to check how patterns with high-load are displayed before finalizing the values.
- *2 When the display panel is large and sufficient display dignity is not available by driving the built-in power supply circuit only, do not use the built-in power supply circuit and supply the voltage for driving the LC from outside.

6.6.5 Precautions at Mounting COG

When mounting the COG, there are resistance components caused by ITO wiring between the IC or external connecting parts (capacitor, resistor) and the power supply. These resistance components may degrade liquid crystal display dignity or may malfunction the IC. When designing modules, take the following three points into account and evaluate them under the practical prerequisites:

- (1) Minimize the resistance between the IC pin and the external connecting parts.
 This IC's boosting circuit is switched with a transistor with very low ON resistance. In mounting the COG, ITO's wiring resistance gets into the switching transistor in series and controls the boosting capacity. Try to make the ITO wiring as thick as possible considering proper wiring to each boosting capacitor.
- (2) Minimize the resistance to the IC power supply pin.
 When current flow changes momentarily as in case of display clock switching, the supply voltage may drop momentarily sometimes. When the ITO's wiring resistance to the power supply pin is high, the supply voltage fluctuates greatly inside the IC and may malfunction the IC. Consider proper wiring of the power line so that stable supply voltage can be supplied to the IC.
 In addition, the power supply VDD2 is provided to this IC separately from the power supply VDD for the logical circuit. When the logical circuit is influenced by noises generated to the power supply circuit if VDD and VDD2 are short-circuited, provide this IC with a power supply independent from VDD and VDD2 or supply a liquid crystal drive voltage from outside without using the built-in power supply.

[Current Load Characteristics of Built-in Boosting Circuit (Reference Value)]

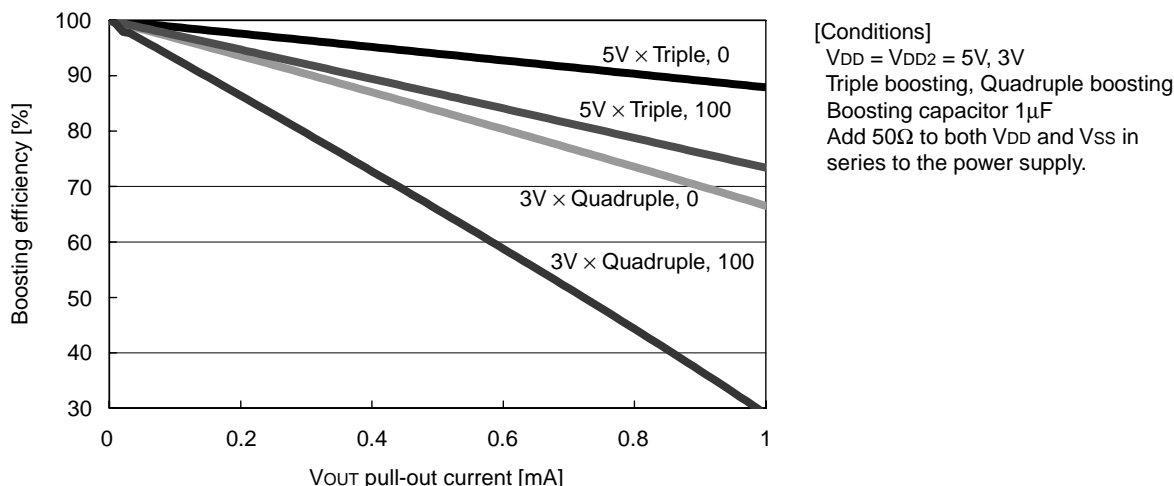

Fig. 6.9

Current load characteristics of built-in boosting circuit without resistance between each CAP pin and capacitor but with /100Ω.

This figure shows changes of the boosting efficiency when the current is pulled out from the VOUT pin and when the VOUT voltage is made 100% at the time of OUT=0mA.

- (3) Prepare a COG module sample by changing the sheet resistance.
 Evaluate the sample after changing the resistance value of the ITO wiring and select the one with sheet resistance as well as some operation margin.

6.6.6 Temperature gradient select circuit

This is a circuit to select the temperature gradient characteristics of the liquid crystal drive power supply voltage. Temperature gradient characteristics can be selected from eight states by the Temperature Gradient command. Selection of temperature gradient characteristics conforming to the temperature characteristics of the liquid crystal to be used makes it possible to configure a system without providing an external element for temperature characteristics compensation.

6.7 Temperature sensor circuit

The S1D15714 Series incorporate a temperature sensor circuit with an analog voltage output pin of the temperature gradient $-4.70 \text{ mV}/^\circ\text{C}$ (Typ.). Input a proper electronic volume resistor value corresponding to the temperature sensor output value from the MPU to control the liquid crystal drive voltage V3, and liquid crystal displays of proper tint will become possible in a wide temperature range.

In order to control liquid crystal drive voltage more precisely, construct a system that feeds back values sampled output voltages at a certain temperature to the MPU and saves them as reference voltages to absorb dispersions of output voltages.

When a large current load is caused to the IC due to high-speed writing in the display RAM, the internal power supply of the IC will be vibrated and correct values may not be output at certain temperature sometimes. So, read temperature sensor outputs only when a large current load is not caused to the IC.

For pins related to the temperature sensor, see 5. Pin Description and 5.5 Temperature Sensor Pin, and for electric characteristics, see 9. DC Characteristics and 9.2 Characteristics of Temperature Sensor.

6.8 Reset circuit

When the $\overline{\text{RES}}$ input becomes LOW, this LSI is set to the initialized state.

The following shows the initially set state:

- | | |
|---------------------------------------------------------------------------------------|----------------------------------------------------------------------------------------------|
| 1. Display : OFF | 20. Discharge : ON (only for when $\overline{\text{RES}} = \text{LOW}$) |
| 2. Display : normal mode | 21. Power save : OFF |
| 3. Display all lighting : OFF | 22. Temperature gradient resistor : (D2, D1, D0) = (0, 0, 0) ($-0.06/^\circ\text{C}$) |
| 4. Common output status : normal | 23. Register data in the serial interface : Clear |
| 5. Display start line : Set to 1st line | 24. MLS drive select register: (D4, D3, D2, D1, D0) = (0, 1, 0, 1, 1) (Non-dispersion drive) |
| 6. Page address : Set to 0 page | 25. Temperature sensor |
| 7. Column address : Set to 0 address | |
| 8. Display data input direction : Column direction | |
| 9. Column address direction : forward | |
| 10. n-line a.c. reverse drive : OFF (reverse drive for each frame) | |
| 11. n-line reverse drive register : (D3, D2, D1, D0) = (1, 1, 0, 0) | |
| 12. DUTY register : (D3, D2, D1, D0) = (0, 0, 1, 1) (1/64 duty) | |
| Start spot (block) register : (D3, D2, D1, D0) = (0, 0, 0, 0) (COM0) | |
| 13. Read modify write : OFF | |
| 14. Built-in oscillation circuit : stop | |
| 15. Oscillation frequency register : (D3, D2, D1, D0) = (0, 0, 0, 0) (60kHz (TBD)) | |
| 16. Power control register : (D2, D1, D0) = (0, 0, 0) | |
| 17. LCD drive voltage selection resistor : (D2, D1, D0) = (0, 0, 0) | |
| 18. LCD bias change register : (D1, D0) = (0, 0) | |
| 19. Electronic volume register : (D6, D5, D4, D3, D2, D1, D0) = (0, 0, 0, 0, 0, 0, 0) | |

When the Reset command is used, only the above-mentioned initialized items 7, 8 and 13 are executed.

When power is turned on, initialization by the $\overline{\text{RES}}$ pin is necessary. After initialization by the $\overline{\text{RES}}$ pin, each input pin must be controlled correctly.

Furthermore, when control signals from the MPU have a high impedance, the excessive current may flow to the IC.

After VDD is applied, measures should be taken to ensure that the input pin does not have a high impedance. The S1D15714 Series discharges the electric charge of VOUT and liquid crystal drive voltage (V3, V2, V1, Vc, MV1, MV2) at the level of $\overline{\text{RES}}$ pin = LOW. When liquid crystal drive external power supply is used, external power supply should not be supplied during the period of $\overline{\text{RES}} = \text{LOW}$ to prevent external power supply and VDD and VSS from being short circuited.

7. COMMAND

The S1D15714 Series identifies data bus signals by a combination of A0, $\overline{RD}(E)$ and $\overline{WR}(R/\overline{W})$. Interpretation and execution of the command are executed by the internal timing alone which is independent of the external clock. This allows high-speed processing.

The 80 series MPU interface allows the command to be started by entering the low pulse in the \overline{RD} pin during reading and by entering the low pulse in the \overline{WR} pin during writing.

The 68 series MPU interface allows a read state to occur by entering HIGH in the R/\overline{W} pin, and permits a write state to occur by entering LOW. It also allows the command to be started by entering the high pulse in the pin E. (For timing, see the description of “10. Timing characteristics”).

Accordingly, the 68 series MPU interface is different from 80 series MPU interface in that $\overline{RD}(E)$ is “1(H)” in the case of display data/read shown in the Command Description and Command Table. The following describes the commands, based on the example of the 80 series MPU interface:

When the serial interface is selected, enter data sequentially starting from D7.

Command Description

(1) Display ON/OFF

This command sets the display ON/OFF.

When Display OFF is specified, the driver common to segments outputs the VC level.

A0	\overline{E} \overline{RD}	$\overline{R/\overline{W}}$ \overline{WR}	D7	D6	D5	D4	D3	D2	D1	D0	Output level
0	1	0	1	0	1	0	1	1	1	0	Display OFF
										1	Display ON

(2) Display Normal/Reverse

This command allows the display ON/OFF state to be reversed, without having to rewrite the contents of the display data RAM. In this case, contents of the display data RAM are maintained.

A0	\overline{E} \overline{RD}	$\overline{R/\overline{W}}$ \overline{WR}	D7	D6	D5	D4	D3	D2	D1	D0	Setting
0	1	0	1	0	1	0	0	1	1	0	RAM data = HIGH LCD ON Voltage (normal)
										1	RAM data = LOW LCD ON Voltage (reverse)

(3) Display All Lighting ON/OFF

This command forces all the displays to be turned on independently of the contents of the display data RAM. In this case, the contents of the display data RAM are maintained. Fully white display can also be made by a combination of the Display Reverse command.

A0	\overline{E} \overline{RD}	$\overline{R/\overline{W}}$ \overline{WR}	D7	D6	D5	D4	D3	D2	D1	D0	Setting
0	1	0	1	0	1	0	0	1	0	0	Normal display status
										1	Display all lighting

(4) Common Output Status Select

This command allows the scanning direction of the COM output pin to be selected. For details, see the description of “6.5.2 COM Drivers” in the Function Description.

A0	\overline{E} RD	$\overline{R/W}$ WR	D7	D6	D5	D4	D3	D2	D1	D0	Selected state	
0	1	0	1	1	0	0	0	1	0	0	Normal	COM0 → COM63 → COMS
										1	Reverse	COM63 → COM0 → COMS

(5) Display Start Line set (2-byte command)

The parameter following this command specifies the display start line address of the display data RAM shown in Fig. 6.4.

The display area is indicated in the direction where line address numbers are incremented, starting from the specified line address. If a dynamic change of the line address is made by this command, smooth scrolling in the longitudinal direction and page breaking are enabled. For details, see the description of “6.2.3 Line address circuit” in the Function Description.

A0	\overline{E} RD	$\overline{R/W}$ WR	D7	D6	D5	D4	D3	D2	D1	D0	
0	1	0	1	0	0	0	1	0	1	0	Mode setting
1	1	0	L7	L6	L5	L4	L3	L2	L1	L0	Register setting

• Display Start Line Set command parameter

L7	L6	L5	L4	L3	L2	L1	L0	Line address
*	*	0	0	0	0	0	0	00H
*	*	0	0	0	0	0	1	01H
*	*	0	0	0	0	1	0	02H
			↓					↓
*	*	1	1	1	1	1	0	3EH
*	*	1	1	1	1	1	1	3FH

Set to line address 000H at the time of resetting.
* : denote invalid bits.

• Line address setting sequence

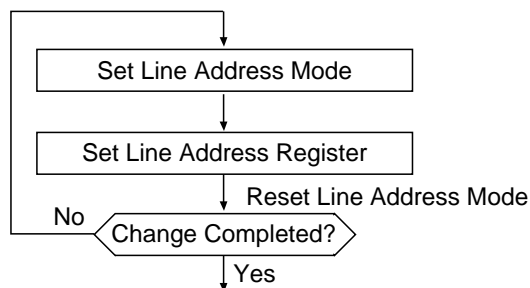

Fig. 7.1

(6) Page Address Set

This command specifies the page address corresponding to row address when MPU access to the display data RAM shown in Fig. 6.4. The column address is split into two sections (higher 4 bits and lower 4 bits) when it is set. Each time the display data RAM is accessed, the column address automatically increments (+1), making it possible for the MPU to continuously read and write the display data. For details, see the description of “6.2.2 Page address circuit” in the Function Description.

A0	\overline{E} RD	$\overline{R/W}$ WR	D7	D6	D5	D4	D3	D2	D1	D0	Page address
0	1	0	1	0	1	1	P3	P2	P1	P0	Page address set

*: denote invalid bits.

P3	P2	P1	P0	Page address
0	0	0	0	Page 0
0	0	0	1	Page 1
		↓		↓
0	1	1	1	Page 7
1	0	0	0	Page 8

(7) Column Address Set

This command specifies the column address of the display data RAM shown in Fig. 6.4. A column address should be set separately, higher 4 bits and lower 4 bits. Since the increment (+1) of the column address is carried out automatically everytime a display data RAM is accessed MPU can Read/Write display data continuously. Please refer to 6.2.2 column address circuits of functional explanation for more details.

A0	\overline{E} RD	$\overline{R/W}$ WR	D7	D6	D5	D4	D3	D2	D1	D0	
0	1	0	0	0	0	1	C7	C6	C5	C4	Column address higher set
0	1	0	0	0	0	0	C3	C2	C1	C0	Column address lower set

C7	C6	C5	C4	C3	C2	C1	C0	Column address
0	0	0	0	0	0	0	0	00H
0	0	0	0	0	0	0	1	01H
0	0	0	0	0	0	1	0	02H
			↓					↓
1	0	1	0	0	1	1	0	A6H
1	0	1	0	0	1	1	1	A7H

(8) Display Data Write

This command allows the 8-bit data to be written to the address specified by the display data RAM. After writing, column address or page address is automatically incremented +1 by the Display Data Input Direction Select command. This enables the MPU to write the display data continuously.

A0	\overline{E} RD	$\overline{R/W}$ WR	D7	D6	D5	D4	D3	D2	D1	D0
1	1	0	Write Data							

(9) Display Data Read

This command allows the 8-bit data to be read from the address specified by the display data RAM. After reading, column address or page address is automatically incremented +1 by the Display Data Input Direction select command. This enables the MPU to read multiple word data continuously.

It should be noted that one dummy reading is essential immediately after the column address or page address has been set. For details, see the description of “6.1.5 Access to display data RAM and internal register” in the Function Description. When the serial interface is used, display data cannot be read.

A0	$\overline{\text{E}}$ RD	$\overline{\text{R/W}}$ WR	D7	D6	D5	D4	D3	D2	D1	D0
1	0	1	Read Data							

(10) Display Data Input Direction Select

This command sets the direction where the display RAM address number is automatically incremented. For details, see the description of “6.2.3 Column address circuit” in the Function Description.

A0	$\overline{\text{E}}$ RD	$\overline{\text{R/W}}$ WR	D7	D6	D5	D4	D3	D2	D1	D0	Direction
0	1	0	1	0	0	0	0	1	0	0	Column
										1	Page

(11) Column Address Set Direction

This command can reverse the relationship between the display RAM data column address and segment driver output shown in Fig. 6.4. So you can reverse the sequence of segment driver output pins using this command. When the display data is written or read, the column address is incremented by (+1) according to the column address given in Fig. 6.4. For details, see the description of “6.2.2 Column address circuit” in the Function Description.

A0	$\overline{\text{E}}$ RD	$\overline{\text{R/W}}$ WR	D7	D6	D5	D4	D3	D2	D1	D0	Setting
0	1	0	1	0	1	0	0	0	0	0	Normal
										1	Reverse

(12) n-line Inversion Drive Register Set

This command sets the liquid crystal alternating drive reverse line count in the register to start line reverse driving operation. The line count to be set is 4 to 60 (15 states for each 4 lines). For details, see the description of “6.4 Display timing generation circuit” in the Function Description.

A0	$\overline{\text{E}}$ RD	$\overline{\text{R/W}}$ WR	D7	D6	D5	D4	D3	D2	D1	D0	Reverse line count
0	1	0	0	0	1	1	N3	N2	N1	N0	Reverse line count

N3	N2	N1	N0	Reverse line count
0	0	0	0	4 (1 × 4)
0	0	0	1	8 (2 × 4)
		↓		↓
1	1	0	1	56 (14 × 4)
1	1	1	0	60 (15 × 4)

(13) n-line Inversion Drive ON/OFF

This command provides ON/OFF control of n-line inverting drive.

A0	\overline{E} RD	$\overline{R/W}$ WR	D7	D6	D5	D4	D3	D2	D1	D0	n-line
0	1	0	1	1	1	0	0	1	0	0	OFF
										1	ON

(14) Duty Set Command

Liquid crystal drive at a lower power consumption is ensured by using this command to change the duty. Use of this command also allows display at a desired position on the panel (continuous CON pins + COM on a 4-line basis). This command is used with a pair of the duty set parameter and start point (block) parameter, so be sure to set both parameters so that one of them will immediately follow the other.

A0	\overline{E} RD	$\overline{R/W}$ WR	D7	D6	D5	D4	D3	D2	D1	D0	Selected state
0	1	0	0	1	1	0	1	1	0	1	Duty set command
0	1	0	U3	U2	U1	U0	S3	S2	S1	S0	Duty set, Start point set

*: denote invalid bits.

• Duty set

Duty can be set in the range from 1/5 duty to 1/65 duty by 4 steps. It should be set in higher 4 bits (D7, D6, D5, D4). Set to 1/65 duty after resetting.

U3	U2	U1	U0	Display duty
0	0	0	0	1/5
0	0	0	1	1/9
0	0	1	0	1/13
0	0	1	1	1/17
0	1	0	0	1/21
0	1	0	1	1/25
0	1	1	0	1/29
0	1	1	1	1/33
1	0	0	0	1/37
1	0	0	1	1/41
1	0	1	0	1/45
1	0	1	1	1/49
1	1	0	0	1/53
1	1	0	1	1/57
1	1	1	0	1/61
1	1	1	1	1/65

• Start point (block) register set parameter

Use this parameter to set 4-bit data in the start point (block) register. Then one of 16 start point blocks will be determined. It should be set in lower 4 bits (D3, D2, D1, D0).

S3	S2	S1	S0	Start piont setting
0	0	0	0	0 (COM0 to 3)
0	0	0	1	1 (COM4 to 7)
0	0	1	0	2 (COM8 to 11)
		↓		↓
1	1	1	0	14 (COM56 to 59)
1	1	1	1	15 (COM60 to 63)

Set to 0 block at the time of resetting

- *1 Voltage optimum to liquid crystal drive is changed when the duty is changed. Use the electronic volume and set the voltage to get the optimum display.
- *2 For display scroll, use (5) Display Start Line Set Command, and do not scroll displays by using this command.

• Duty command setup example

1. Duty 1/49 When 1 (COM4 to COM7) is specified as the start point (block)
Display area COM4 to COM51, COMS
2. Duty 1/33 When 10 (COM44 to COM47) is specified as the start point (block)
Display area COM44 to COM63 and COM0 to COM11, COMS

* When the COM pin is not commonly used for the master and the slave in a master/slave two-chip operation (SEG 168 pieces are made common and two screens of 168×120dots are driven up and down with COM 60 pieces + COM 60 pieces), the display thick will become different between the master-side display area and the slave-slave display area unless the master and the salve a re of the same duty. Set a same duty to both the master and the slave. When either the master side or the slave side is not displayed, input the Display OFF Command to the side, which you do not want to display, so that the VC level is output.

(15) Read Modify Write

This command is paired with end command for use. If this command is entered, the column address is not changed by the Display Data Read command. It can be incremented +1 by the Display Data Read command alone. This state s retained until the End command is input. If the End command is input, the column address goes back to the address when the Read Modify Write command is input. This function reduces the MPU loads when changing the data repeated in the specific display area such as blinking cursor.

A0	$\overline{\text{E}}$ RD	$\overline{\text{R/W}}$ WR	D7	D6	D5	D4	D3	D2	D1	D0
0	1	0	1	1	1	0	0	0	0	0

* A command other than display data Read/Write command can be used in the Read Modify Write mode. However, you cannot use the column address set command.

• Sequence for cursor display

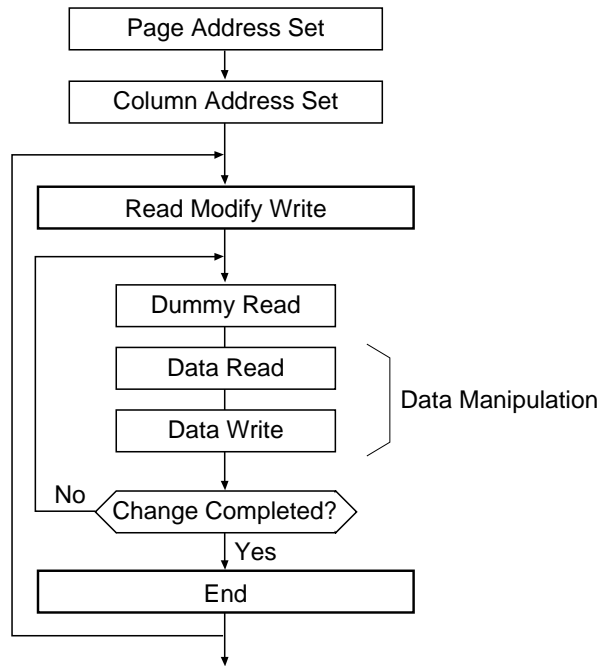

Fig. 7.2

(16) End

This command releases the read modify write mode and gets column address back to the initial address of the mode.

A0	\overline{E} RD	$\overline{R/W}$ WR	D7	D6	D5	D4	D3	D2	D1	D0
0	1	0	1	1	1	0	1	1	1	0

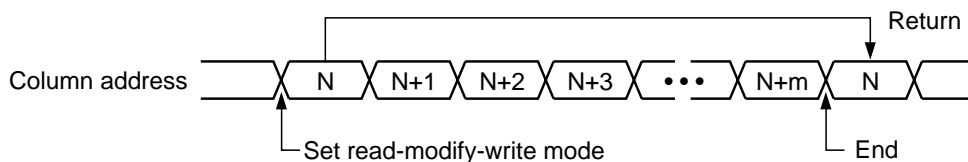

Fig. 7.3

(17) Built-in Oscillator Circuit ON/OFF

This command starts the built-in oscillator circuit operation. It is enabled only in the master operation mode (M/S = HIGH) when built-in oscillator circuit is valid (CLS = HIGH).

When the built-in power supply is used, the Oscillator Circuit ON command must be executed before the Power Control Set command. (See the description of “(21) power control command”). If the built-in oscillator circuit is turned off when the built-in power supply is used, display failure may occur.

A0	\overline{E} RD	$\overline{R/W}$ WR	D7	D6	D5	D4	D3	D2	D1	D0	Built-in oscillator circuit
0	1	0	1	0	1	0	1	0	1	0	OFF
										1	ON

(18) Built-in Oscillator Circuit Frequency Select

This command sets the built-in oscillator circuit frequency. The frequency can be selected whether the built-in oscillator circuit is turned on or off.

A0	$\frac{E}{RD}$	$\frac{R/\overline{W}}{WR}$	D7	D6	D5	D4	D3	D2	D1	D0	f _{CL} kHz
0	1	0	0	1	1	1	F3	F2	F1	F0	Frequency Set

F3	F2	F1	F0	CL Frequency f _{CL} [kHz]	Frame frequency, f _{FR} [Hz]		
					1/65Duty	1/49Duty	1/33Duty
0	0	0	0	100	92	120	174
0	0	0	1	86.8	80	104	151
0	0	1	0	78.0	72	94	135
0	0	1	1	69.8	64	84	121
0	1	0	0	65.1	60	78	113
0	1	0	1	59.4	55	71	103
0	1	1	0	55.3	51	66	96
0	1	1	1	51.3	47	62	89
1	0	0	0	49.0	45	59	85
1	0	0	1	45.8	42	55	80
1	0	1	0	43.5	40	52	75
1	0	1	1	41.0	38	49	71
1	1	0	0	39.4	36	47	68
1	1	0	1	37.4	34	45	65
1	1	1	0	35.8	33	43	62
1	1	1	1	34.1	31	41	59

(F3, F2, F1, F0) = (0, 0, 0, 0) is set after resetting.

* The values in the above table are representative values at 25°C. Consider that there are dispersions of ±8% at 25°C. f_{FR} means the cycle to rewrite a screen (frame frequency) and is calculated from the following equation:

$$f_{FR} = \frac{f_{CL}}{(n+3) \times 16} \quad (n = 1/Duty)$$

This does not indicate the frequency of the f_{FR} signal.

(19) Power Control Set

This command sets the built-in power supply circuit function. For details, see the description of “6.6 Power supply circuit” in the Function Description.

A0	$\overline{\text{RD}}$	$\overline{\text{WR}}$	D7	D6	D5	D4	D3	D2	D1	D0	Selected state
0	1	0	0	0	1	0	0	1	0	1	Command
1	1	0	0	0	0	0	0	P2	P1	P0	Register set

P2	P1	P0	Selected state
0			Step-up: OFF
1			Step-up: ON
	0		V3: OFF
	1		V3: ON
		0	LCD voltage: OFF
		1	LCD voltage: ON

V3 : Voltage adjustment circuit (V3 adjustment circuit)
 LCDV : Liquid crystal rive potential (V2, V1, VC, NV1, NV2) generation circuit

An internal clock is required to operate the built-in power supply circuit. During the operation of the built-in power supply circuit, be sure that the internal clock is present inside.

If the built-in oscillator circuit is used, execute the built-in oscillator circuit ON command before the power control set command. If an external oscillator circuit is used, operate the external oscillator circuit before the power control set command.

If the internal clock is cut off during the operation of the built-in power supply circuit, display failure may occur. To avoid this, do not cut it off.

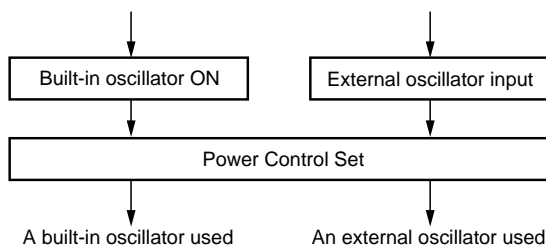

Fig. 7.4

(20) Liquid Crystal Drive Voltage Select

The liquid crystal drive voltage range issued from the liquid crystal drive voltage regulating circuit is selected from 3 states by this command.

A0	$\overline{\text{E}}_{\text{RD}}$	$\overline{\text{R/W}}_{\text{WR}}$	D7	D6	D5	D4	D3	D2	D1	D0	V3 voltage output range
0	1	0	0	0	1	0	0	V2	V1	V0	V3 voltage range set

V2	V1	V0	V3 voltage output range
0	0	0	5.6 to 7.0V
0	0	1	6.3 to 7.8V
0	1	0	7.1 to 8.9V
0	1	1	8.0 to 10.0V
1	0	0	9.2 to 11.4V
1	0	1	10.3 to 12.8V
1	1	0	11.7 to 14.5V
1	1	1	12.8 to 16.0V

(V2, V1, V0) = (0, 0, 0) is set after resetting.

(21) LCD Bias Change

With this command, the bias ratio of liquid crystal drive voltage should be chosen from 4 states.

A0	$\overline{\text{E}}_{\text{RD}}$	$\overline{\text{R/W}}_{\text{WR}}$	D7	D6	D5	D4	D3	D2	D1	D0	Bias ratio
0	1	0	0	1	0	1	0	0	B1	B0	Bias ratio set

B1	B0	Bias ratio
0	0	1/8
0	1	1/6.7
1	0	1/5.3

(22) Electronic Volume

This command controls liquid crystal drive voltage V₃ issued from the built-in liquid crystal power supply voltage regulating circuit, and adjusts the liquid crystal display density. For details, see the description of “6.6.2 Voltage Regulating Circuit” in the Function Description.

A0	E RD	R/W WR	D7	D6	D5	D4	D3	D2	D1	D0	
0	1	0	1	0	0	0	0	0	0	1	Mode set
0	1	0	R7	R6	R5	R4	R3	R2	R1	R0	Register

• Electronic Volume Mode Set

Inputting this command makes the Electronic Volume Register Set Command valid. Once the Electronic Volume Mode Set Command is input, any command other than the Electronic Volume Register Set Command cannot be used. After data are saved in the register by the Electronic Volume Register Set Command, this command is released.

• Electronic Volume Register Set

When a 7-bit data to the electronic volume register is set by this command, liquid crystal drive voltage V₃ assumes one state out of voltage values in 128 states. After this command is input, and the electronic volume register is set, the electronic volume mode is reset.

R7	R6	R5	R4	R3	R2	R1	R0	V _c
*	0	0	0	0	0	0	0	Smaller
*	0	0	0	0	0	0	1	
*	0	0	0	0	0	1	0	
			↓					↓
*	1	1	1	1	1	1	0	
*	1	1	1	1	1	1	1	Larger

*: denote invalid bits.

• Electronic volume register set sequence

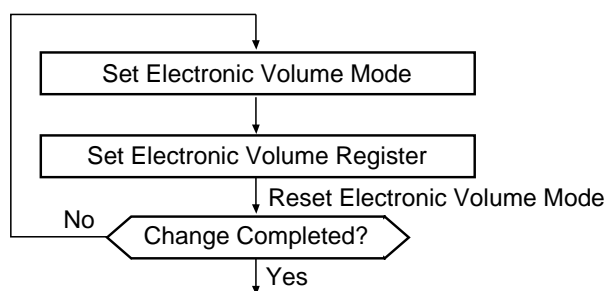

Fig. 7.5

(23) Discharge ON/OFF

This command discharges the capacitors connected to the power supply circuit. This command is used when the system power of this IC (S1D15714 Series) is turned off, and the duty is changed. See the description of (3) Power Supply OFF and (4) Changing the Duty in the Instruction Setup: Reference.

A0	$\overline{\text{E}}$ RD	$\overline{\text{R/W}}$ WR	D7	D6	D5	D4	D3	D2	D1	D0	Setting
0	1	0	1	1	1	0	1	0	1	0	Discharge OFF
										1	Discharge ON

* If this command is executed when the external power supply is used, a large current may flow to damage the IC. If external power supply is used to drive liquid crystal, be sure to turn off the external power supply before executing this command.

(24) Power Saving

This command establishes the power save mode, thereby ensuring a substantial reduction of current consumption.

A0	$\overline{\text{E}}$ RD	$\overline{\text{R/W}}$ WR	D7	D6	D5	D4	D3	D2	D1	D0	Power save mode
0	1	0	1	0	1	0	1	0	0	0	OFF
										1	ON

In the power save mode, display data and operation before power saving are maintained. Access to the display data RAM from the MPU is also possible. The current consumption is reduced to the value close to static current if all operations of the LCD display system are stopped and there is no access from the MPU.

In the power save mode, the following occurs:

- Stop of oscillator circuit
- Stop of LCD power supply circuit
- Stop of all liquid crystal drive circuit (Vss level output is issued as the segment and common driver output).

When the temperature sensor is set to ON, the sensor circuit operates even under the power saving status. To reduce current consumption, use the Temperature Sensor ON/OFF Command to control current as the need arises.

When the Power Save OFF Command is input, the power saving status will be released, and the system will return to the status before the power save mode started.

• Power Save Sequence

Fig. 7.6

* When the external power supply is used, it is recommended to stop the external power supply circuit function when the power save mode is started. For example, when each level of the liquid crystal drive voltage is given from the external resistive divider circuit, it is recommended to add a circuit to cut off the current flowing to the resistive divider circuit when power save function is started. The S1D15714 Series has a liquid crystal display blanking control pin DOF, and the level goes LOW when power save function is started. You can use the DOF output to stop the external power supply circuit function.

(25) Temperature Gradient Set

The 3-bit data of this command is used to set the temperature gradient characteristics of the liquid crystal drive voltage output from the built-in power supply circuit from eight states to one state. The temperature gradient of the liquid crystal drive voltage can be set according to the liquid crystal temperature gradient to be used. This eliminates the need of a temperature characteristics regulating circuit to be installed outside this IC (S1D15714 Series).

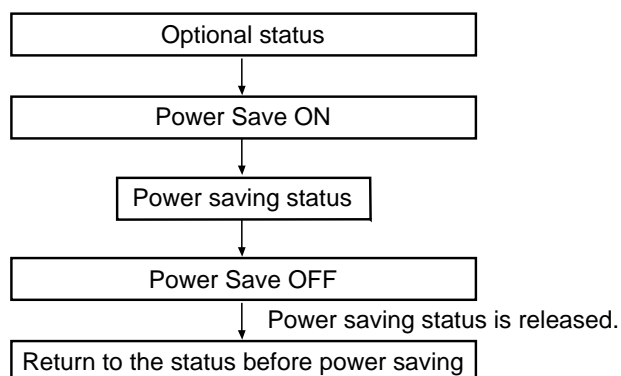
A0	\overline{E} RD	$\overline{R/W}$ WR	D7	D6	D5	D4	D3	D2	D1	D0	Temperature gradient [%/°C]
0	1	0	0	1	0	0	1	T2	T1	T0	Temperature gradient set

T2	T1	T0	Temperature gradient [%/°C]
0	0	0	-0.06
0	0	1	-0.08
0	1	0	-0.10
0	1	1	-0.11
1	0	0	-0.13
1	0	1	-0.15
1	1	0	-0.17
1	1	1	-0.18

(T2, T1, T0) = (0, 0, 0) is set after resetting. *: denote invalid bits.

(26) Status Read

This command reads out the temperature gradient select bit set on the register. After inputting the Status Read Mode Set Command, continue reading. After the status reading ends, the Status Read Mode will be released.

A0	\overline{E} RD	$\overline{R/W}$ WR	D7	D6	D5	D4	D3	D2	D1	D0	Temperature gradient [%/°C]
0	1	0	1	0	0	0	1	1	1	0	Mode Set
0	0	1	*	*	*	*	*	T2	T1	T0	Register

*: denote invalid bits.

T2	T1	T0	Temperature gradient [%/°C]
0	0	0	-0.06
0	0	1	-0.08
0	1	0	-0.10
0	1	1	-0.11
1	0	0	-0.13
1	0	1	-0.15
1	1	0	-0.17
1	1	1	-0.18

(27) Reset

This command resets the column address and the page address to 0 and releases the read modify write mode and test mode without giving adverse effect to the display data RAM. For details, see the description of “6.7 Reset” in Function Description. Resetting is carried out after the reset command has been input.

A0	\overline{E} RD	$\overline{R/W}$ WR	D7	D6	D5	D4	D3	D2	D1	D0
0	1	0	1	1	1	0	0	0	1	0

Initialization upon application of power supply is carried out by the reset signal to the \overline{RES} pin. The reset command cannot be used for this purpose.

(28) Temperature Sensor ON/OFF

ON/OFF of a temperature sensor is specified with this command.

A0	\overline{E} RD	$\overline{R/W}$ WR	D7	D6	D5	D4	D3	D2	D1	D0	Set up
0	1	0	0	1	1	0	1	0	0	0	Temperature sensor OFF
										1	Temperature sensor ON

The temperature sensor off is set up after reset.

When using a built-in temperature sensor, the temperature sensor should be ON by using this command. Although there is no problem setting a temperature sensor ON even if it is not used, 10 μ A grade current is consumed. The temperature sensor circuit is independently controlled from the Power Save Command.

(29) MLS Drive Select (2-byte Command)

This command is for selecting MLS drives and switches the dispersion drive and the non-dispersion drive. This command is a 2-byte command and is used together with the MLS Drive Select Mode Set Command and the MLS Drive Select Pattern Set Command. Be sure to input the both command in succession.

A0	\overline{E} RD	$\overline{R/W}$ WR	D7	D6	D5	D4	D3	D2	D1	D0	
0	1	0	1	1	1	0	0	1	1	1	Mode Set
0	1	0	*	*	*	0	M3	0	1	1	Pattern Set

* denotes invalid bit.

M3	M2	M1	M0	Pattern Set
0	0	1	1	Dispersion Drive
1	0	1	1	Non-dispersion Drive

The non-dispersion drive is set after resetting.

* The dispersion drive and the non-dispersion drive are liquid crystal driving methods unique to the MLS drive. The SID15714 Series adopt 4-line MLS drive. Selected voltages are output for the period (the period of $4/(65+3)$ of one frame for 65-line display) of about quadruple the selection period for the normal drive mode in which one line is selected and scanned each time (the period of $1/65$ of one frame for 65-line display). In the non-dispersion drive, selection signals of 4-line data are output 4 times in succession. We recommend this drive when displays are frequently changed. In case of the dispersion drive, selection signals are divided into and output 4 times in one frame period. This driving method allows reducing the frame frequency. To reduce consumption current, we recommend this drive. In this case, however, displays may blink, and this drive is not suitable for movie display.

(30) NOP

This is a Non-Operation command.

A0	$\overline{\text{E}}$ RD	$\overline{\text{R/W}}$ WR	D7	D6	D5	D4	D3	D2	D1	D0
0	1	0	1	1	1	0	0	0	1	1

Note: S1D15714 Series maintains the operation status due to the command. However, when exposed to excessive external noise, internal status may be changed. This makes it necessary to take some measures which reduces noise generation in terms of installation or system configuration, or which protects the system against adverse effect of noise. To cope with sudden noise, it is recommended to refresh the operation status on a periodic basis.

Table 7.1 Table of commands in S1D15714 Series series

Command	Command code										Function	
	A0	RD	WR	D7	D6	D5	D4	D3	D2	D1		D0
(1) Display ON/OFF	0	1	0	1	0	1	0	1	1	1	0	LCD display ON/OFF control. 0: OFF, 1: ON
(2) Display Normal /Reverse	0	1	0	1	0	1	0	0	1	1	0	LCD display normal/reverse 0: Normal, 1: Reverse
(3) Display All Lighting ON/OFF	0	1	0	1	0	1	0	0	1	0	0	Display All Lighting 0: Normal display, 1: All ON
(4) Common Output Status Select	0	1	0	1	1	0	0	0	1	0	0	Selects COM output scan direction. 0: Normal, 1: Reverse
(5) Display Start Line Set	0	1	0	1	0	0	0	1	0	1	0	Sets display start line.
(6) Page Address Set	0	1	0	1	0	1	1	0	0	0	1	Sets the display RAM page address.
(7) Column Address Set Higher bits	0	1	0	0	0	0	1	Higher column address			Higher 4 bits of column address in Display RAM are set. Lower 4 bits of column address in Display RAM are set.	
Column Address Set Lower bits	0	1	0	0	0	0	0	Lower column address				
(8) Display Data Write	1	1	0	Writes data							Writes data to the display RAM.	
(9) Display Data Read	1	0	1	Reads data							Reads data to the display RAM.	
(10) Display Data Input Direction Select	0	1	0	1	0	0	0	0	1	0	0	Display RAM data input direction 0: Column direction 1: Page direction
(11) Column Address Set Direction	0	1	0	1	0	1	0	0	0	0	0	Compatible with display RAM address SEG output 0: Normal 1: Reverse
(12) n-line inversion Drive Register Set	0	1	0	0	0	1	1	Invert line count			Line invert drive. Sets the line count.	
(13) n-line ON/OFF	0	1	0	1	1	1	0	0	1	0	0	Resets the line invert drive. 0: n-line OFF 1: n-line ON
(14) Duty Set Command	0	1	0	0	1	1	0	1	1	0	1	2 byte command
Duty Set Static spot set	0	1	0	*	*	Static spot (block)						
(15) Read Modify Write	0	1	0	1	1	1	0	0	0	0	0	Increases the column address. Increases +1 in the write mode. Does not increment in the read mode.
(16) End	0	1	0	1	1	1	0	1	1	1	0	Resets read modify write functions.
(17) Built-in Oscillator Circuit ON/OFF	0	1	0	1	0	1	0	1	0	1	0	Built-in oscillator circuit operation 0: OFF, 1: ON
(18) Built-in Oscillator Circuit Frequency Select	0	1	0	0	1	1	1	Frequency				
(19) Power Control Set	0	1	0	0	0	1	0	1	Operation state		Selects built-in power supply operation state.	
(20) Liquid Crystal Drive Voltage Select	0	1	0	0	0	1	0	0	V ₃ range			
(21) LCD bias change	0	1	0	1	0	1	0	0	0	bias		Bias ratio select
(22) Electronic Volume Mode Set	0	1	0	1	0	0	0	0	0	0	1	V ₃ output voltage is set to the electronic volume register. 128 states
Electronic Volume Register Set	0	1	0	*	Electronic volume							
(23) Discharge ON/OFF	0	1	0	1	1	1	0	1	0	1	0	Discharges Power supply circuit connection capacitor. 0: OFF (normal), 1: ON
(24) Power Save ON/OFF	0	1	0	1	0	1	0	1	0	0	0	Power Save 0: OFF, 1: ON
(25) Temperature Gradient Select	0	1	0	0	1	0	0	1	Temperature gradient		Sets to 8 steps.	
(26) Stator Read	0	1	0	1	0	0	0	1	1	1	0	Issues the temperature gradient select bit. * : denote invalid bits.
	0	0	1	*	*	*	*	*Temperature gradient				
(27) Reset	0	1	0	1	1	1	0	0	0	1	0	Resets the column, page and address registers. Resets the read modify write function.
(28) Temperature Sensor ON/OFF	0	1	0	0	1	1	0	1	0	0	0	Temperature sensor 0 : OFF (normal), 1 : ON
(29) MLS Drive Select (2-byte command)	0	1	0	1	1	1	0	0	1	1	1	Mode Set MLS 0 : Dispersion, 1: Non-dispersion
(30) NOP	0	1	0	1	1	1	0	0	0	1	1	Non-operation command

Instruction Setup Example (Reference)

(1) Initial setup

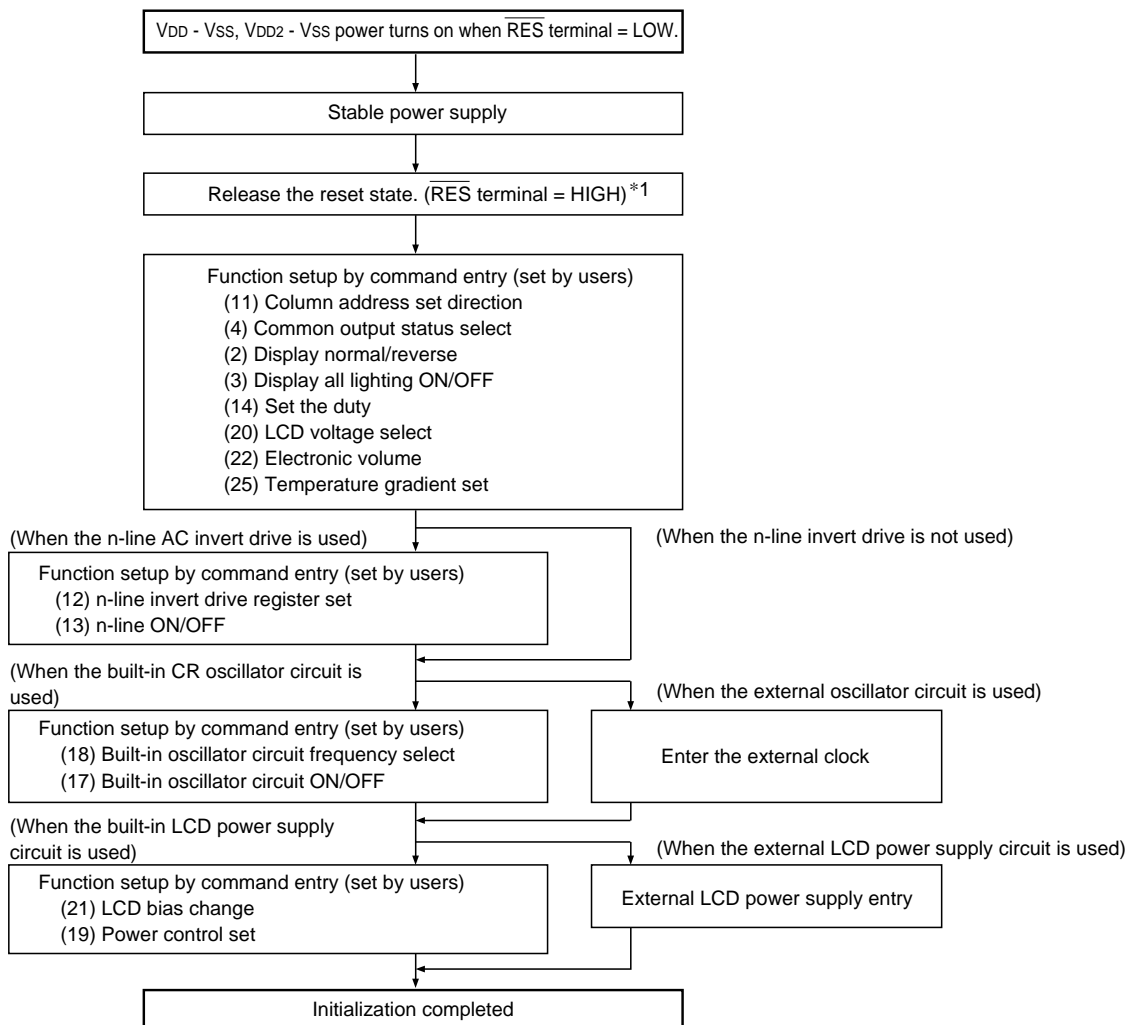

Note: *1 DDRAM contents are not determined even in the initialized state after resetting. See “6.7 Reset Circuit” in the “6. Function Description”.

* Numerals in the command parenthesis correspond to the numerals of the items in Command Description.

(2) Data display

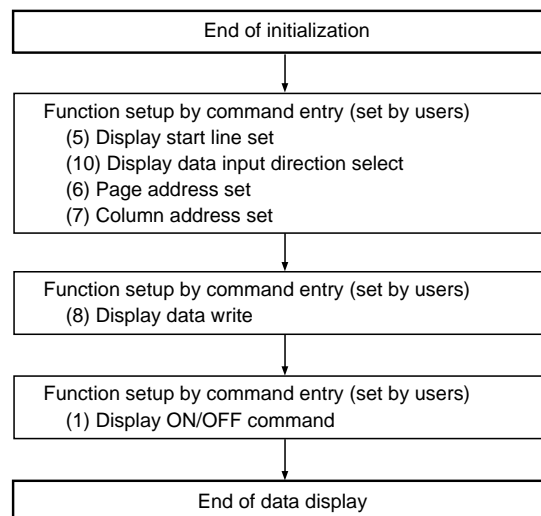

Note: * DDRAM contents are not determined after end of initialization. Write data to all the DDRAM used for display. See “9. Display data write” in the “7. Command Description”.

(3) Power OFF

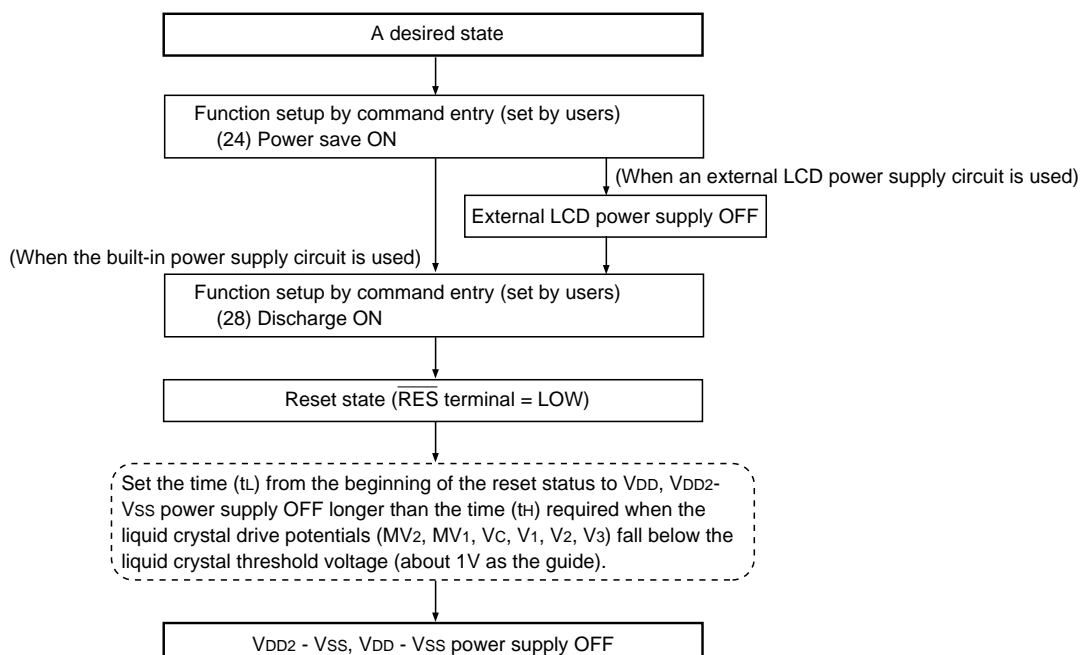

Note: * This IC controls the circuit of the liquid crystal drive power supply system using the VDD, VDD2–VSS power supply circuit. If the VDD, VDD2–VSS power supply is cut off with voltage remaining in the liquid crystal drive power supply system, voltage not controlled will be issued from the SEG and COM pins, and this may result in display failure. To avoid this, follow the above-mentioned power off sequence.

(4) How to change the duty

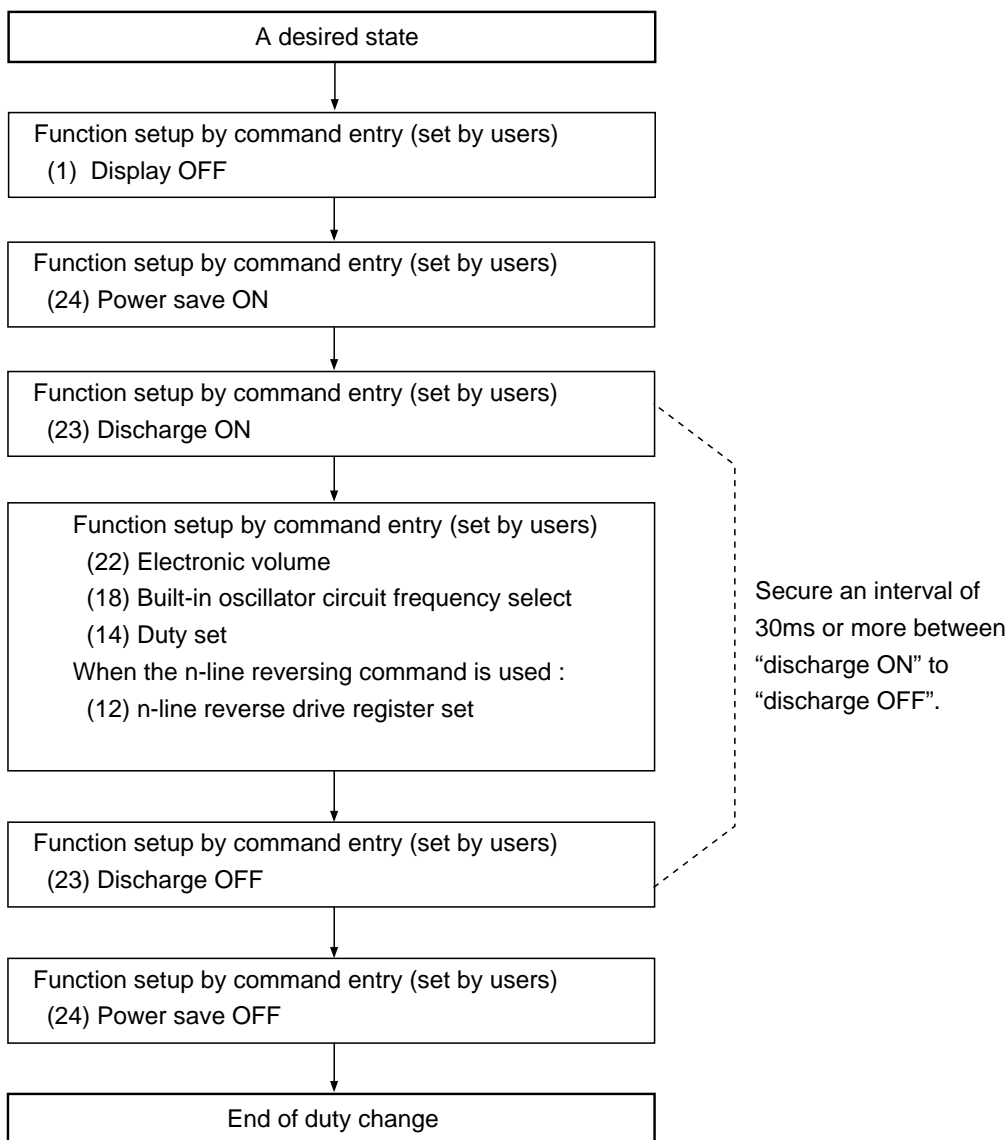

Note: * In the above sequence, the display disappears for the time from Power Save ON to Power Save OFF + about 350ms (in case of frame frequency 80Hz). When the Duty Set Command is executed while the liquid crystal display is on, there may occur the trouble that the display blinks momentarily. Observe the above sequence strictly.

(5) Refresh

It is recommended that the operating modes and display contents be refreshed periodically to prevent the effect of unexpected noise.

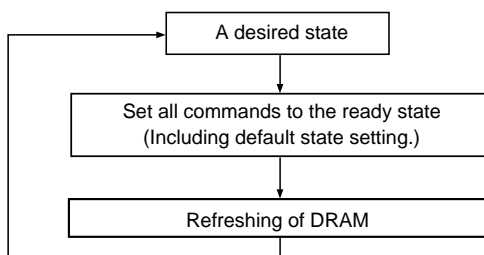

8. ABSOLUTE MAXIMUM RATINGS

Table 8.1

V_{SS} = 0V unless otherwise specified.

Item	Symbol	Specified value	Unit
Power voltage (1)	V _{DD}	-0.3 to +6.0	V
Power voltage (2)	V _{DD2}	-0.3 to +6.0	
Power voltage (3) when external input	V _{DI}	-0.3 to 3.6	
Power voltage (4)	V ₃ , V _{OUT}	-0.3 to 18.0	
Power voltage (5)	V ₂ , V ₁ , V _C , MV ₁ , MV ₂	-0.3 to V ₃	
Input voltage	V _{IN}	-0.3 to V _{DD} +0.3	
Output voltage	V _O	-0.3 to V _{DD} +0.3	
Operating temperature	T _{OPR}	-40 to +85	°C
Storage temperature	bare chip T _{STR}	-55 to +125	

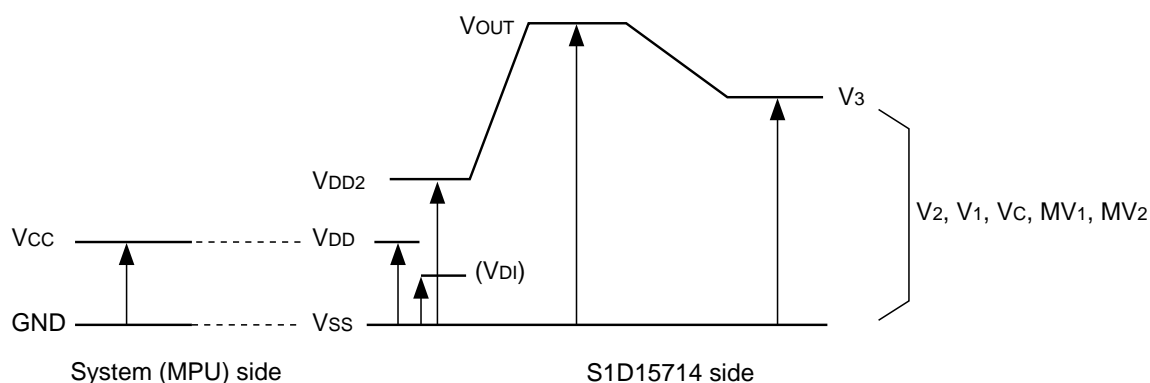

Fig. 8.1

- Notes:
1. Voltages V₃, V₂, V₁, V_C, MV₁, MV₂ and MV₃ (V_{SS}) must always meet the conditions of V₃ ≥ V₂ ≥ V₁ ≥ V_C ≥ MV₁ ≥ MV₂ ≥ MV₃ (V_{SS}).
 2. Voltage V_{OUT} must always meet the conditions of V_{OUT} ≥ V_{DD2} ≥ V_{DD}.
When inputting V_{OUT} from outside, maintain the condition of V_{OUT} ≥ V₃ + 0.2V.
 3. If the LSI has been used in excess of the absolute maximum rating, it may be subjected to permanent breakdown. So in the normal operation, the LSI is preferred to be used under the condition of electrical characteristics. If this condition is not met, LSI operation error may occur and LSI reliability may be deteriorated.

9. DC CHARACTERISTICS

VSS = 0V, VDD = (5V±10%) and Ta = -40 to +85°C unless otherwise specified.

Table 9.1

Item		Symbol	Conditions	Specified value			Unit	Applicable pin
				Min.	Typ.	Max.		
Working voltage (1)	Operation enabled	VDD	—	2.7	—	5.5	V	VDD *1
Working voltage (2)	Operation enabled	VDD2	—	VDD	—	5.5		VDD2
Working voltage (3)	Operation enabled	VDI	External input	2.7	—	3.3		VDI
Working voltage (4)	Operation recommended	VOUT	—	VDD2	—	16.2		VOUT
Working voltage (5)	Operation enabled	V3	—	5.6	—	16.2		V3 *2
High-level input voltage		VIHC	VDD=2.7V to 5.5V	0.8×VDD	—	VDD		*3
Low-level input voltage		VILC		VSS	—	0.2×VDD		*3
High-level output voltage (1)		VOHC1	VDD=2.7V to 5.5V	0.8×VDD	—	VDD		*4
Low-level output voltage (1)		VOLC1		IOH=-25µA IOL=25µA	VSS	—		0.2×VDD
High-level output voltage (2)		VOHC2	VDD=2.7V to 5.5V	0.8×VDD	—	VDD		*5
Low-level output voltage (2)		VOLC2		IOH=-100µA IOL=100µA	VSS	—		0.2×VDD
High-level output voltage (3)		VOHC3	VDD=2.7V to 3.3V	0.8×VDI	—	VDI		*6
Low-level output voltage (3)		VOLC3		IOH=-100µA IOL=100µA	VSS	—		0.2×VDI
Input leak current		ILI	VIN=VDD or VSS	-1	—	1	µA	*7
Output leak current		ILO		-3	—	3		*8
LCD driver ON resistance		RON	Ta=25°C V3=7.2V V3=14.0V	— —	10 5	20 10	kΩ	SEGN COMn *9
Static current consumption		IDDQ I3Q	Ta=25°C VDD=3.0V V3=16V	— —	0.3 5	5 20		µA
Input pin capacity		CIN	Ta=25°C, f=1MHz	—	8	16	pF	—
Oscillation frequency	Internal oscillation	fCL	Ta=25°C at the maximum frequency	92	100	108	kHz	*11
	External input	fCL	Ta=25°C at the maximum frequency	92	100	108		*11

[Asterisked references]

- *1. Does not guarantee if there is an abrupt voltage variation during MPU access.
- *2. For VDD2 and V3 system operating voltage range, see Fig. 9.4.
Applicable when the external power supply is used.
- *3. A0, D0 to D5, D6(SCL), D7(SI), RD(E), WR(R/W), CS, CS2, CLS, CL, FR, F1, F2, SYNC, M/S, C86, P/S, DOF, RES, TEST and TEST 1 pins.
- *4. Do to D7 pin.
- *5. CL pin.
- *6. FR, DOF, F1, F2, SYNC pins.
- *7. A0, RD(E), WR(R/W), CS, CLS, M/S, C86, P/S, RES, TEST and TEST 1 pins.
- *8. Applicable when D0 to D5, D6(SCL), D7(S1), CL, FR, DOF, F1, F2 and SYNC pins have a high impedance.
- *9. Indicates the resistance when 0.1V voltage is applied between the output pin SEGN or COMn and each power supply (V2, V1, VC, MV1, MV2).
RON =0.1V/ΔI (where ΔI denotes current when 0.1V is applied when power is on).
- *10. Current value when TEST1 = LOW
- *11. For the relations between oscillation frequency and frame frequency, see Table 9.7. Specified values of external input items are recommended.

Table 9.2

Item	Symbol	Conditions	Specified value			Unit	Applicable pin	
			Min.	Typ.	Max.			
Built-in power circuit	Input voltage	V _{DD2}	Equal boosting	2.7	—	5.5	V	V _{DD2}
		V _{DD2}	Double boosting	2.7	—	5.5		
		V _{DD2}	Triple boosting	2.7	—	5.3		
V _{DD2}		Quadruple boosting	2.7	—	4.0			
V _{DD2}		Quintruple boosting	2.7	—	3.2			
	Amplified output voltage	V _{OUT}	—	—	16.2	V _{OUT}		
	Voltage adjusting circuit operating voltage	V ₃	—	5.6	—	16.2	V ₃ *12	

*12. The V₃ voltage adjusting circuit is adjusted within the electronic volume operating range.

Dynamic current consumption value (1)

The built-in power supply is ON while the display is on.

Table 9.3 All displays in white

Symbol : I_{SS}(1)

V _{DD}	Boosting	V ₃ voltage	1/65 Duty		1/33 Duty		Unit	Remarks
			Typ.	Min.	Typ.	Min.		
5V	Triple	14V	64	107	48	80	μA	*13
		10V	61	102	45	75		
	Double	8V	60	100	42	70		
3V	Quintuple	14V	74	123	—	—		
	Quadruple	10V	61	102	47	78		
	Triple	8V	57	95	42	70		

[* marked section: Refer to page 51.]

Table 9.4 Display heavy load display *14

Symbol : I_{SS}(1)

V _{DD}	Boosting	V ₃ voltage	1/65 Duty		1/33 Duty		Unit	Remark
			Typ.	Min.	Typ.	Min.		
5V	Triple	14V	103	172	66	110	μA	*13
		10V	82	137	55	92		
	Double	8V	72	120	47	78		
3V	Quintuple	14V	128	213	—	—		
	Quintuple	14V	86	143	58	97		
	Triple	8V	72	120	49	82		

[* marked section: Refer to page 51.]

- Current consumption under power saving mode: $V_{SS} = 0V$, $V_{DD} = 5V$, $TEST1 = HIGH$, $T_a = 25^{\circ}C$

Table 9.5

Item	Symbol	Condition	Specified value			Unit	Remarks
			Min.	Typ.	Max.		
Sleep state	I _{DD} S1	—	—	6	20	μA	—

- Current Consumption at power saving(2) $V_{SS} = 0V$, $V_{DD} = V_{DI} = 3V$, $TEST1 = LOW$, $T_a = 25^{\circ}C$

Table 9.6 Temperature sensor characteristics

Item	Symbol	Condition	Specified value			Unit	Applicable pin
			Min.	Typ.	Max.		
Sleep state	I _{DD} S1	—	—	0.3	5	μA	—

[Reference Data 1]

- Dynamic current consumption during LCD display when the internal power supply is used. $V_3 = 14V$ *13

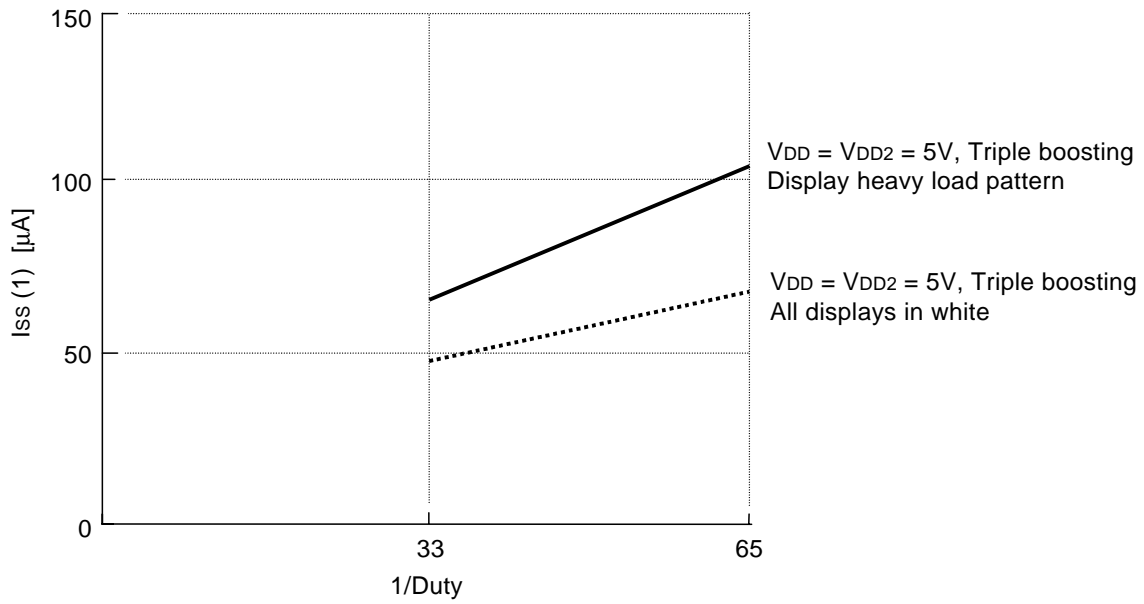

Fig. 9.1

[Reference Data 2]

- Dynamic current consumption during LCD display when the internal power supply is used. $V_3 = 10V$ *13

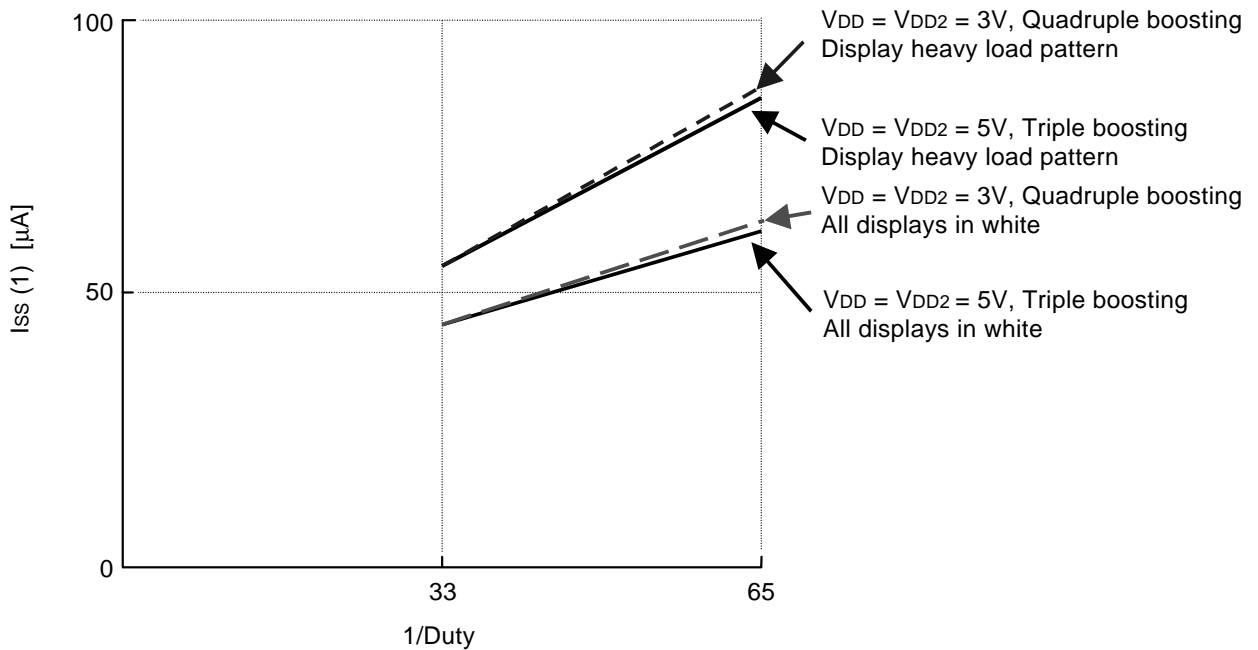
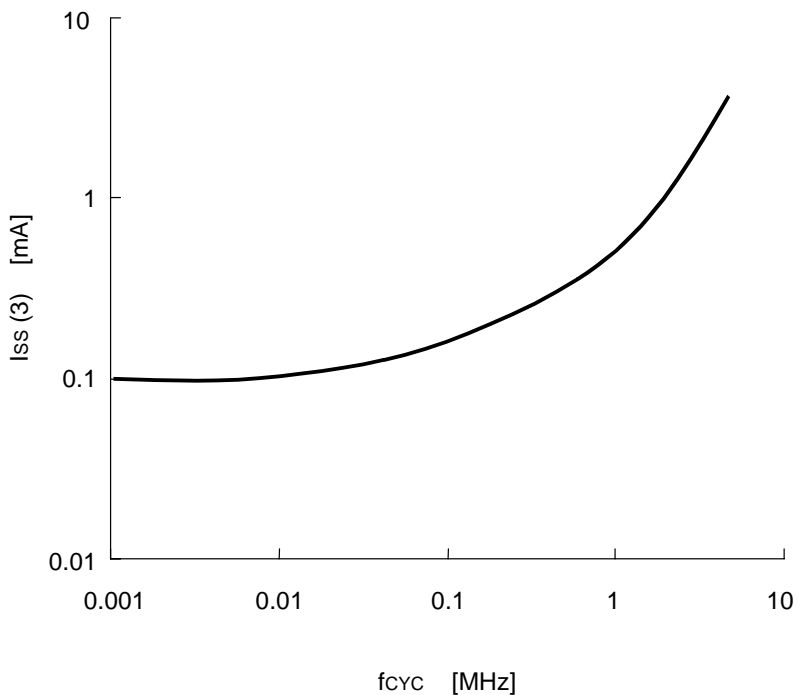

Fig. 9.2

[For the items marked with *, see Page 51.]

[Reference Data 3]

- Dynamic current consumption during access



This indicates the current consumption when the heavy load pattern is always written by f_{cyc}.
When not accessed, only I_{ss}(1) remains.

Conditions : V_{DD} = V_{DD2} = 5.0V,
V₃ = 14V
*13

Fig. 9.3

[Reference Data 4]

- Operating voltage range of V_{DD} and V₃ Systems
(Applicable when an external power supply is used.)

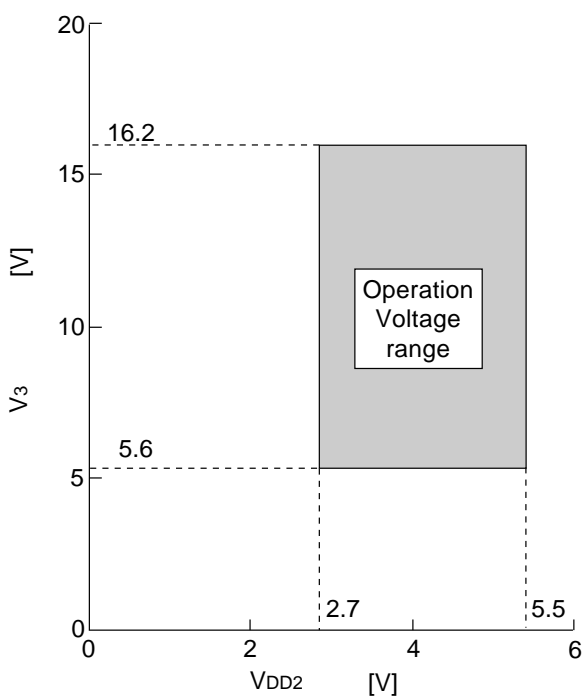

Fig. 9.4

[For the item marked with *, see Page 51.]

- Relationship between oscillation frequency fOSC, display clock frequency fCL and liquid crystal frame fFR

Table 9.7

Item	fCL	fFR
Built-in oscillator circuit used	See p.33	$\frac{f_{CL}}{(n+3) \times 16}$
Built-in oscillator circuit not used	External input (fCL)	$\frac{f_{CL}}{(n+3) \times 16} (n = \frac{1}{\text{Duty}})$

(fFR indicates the cycle of rewriting one screen; it does not indicate FR signal cycle.)

[Reference Matters for Items marked with *]

*13 Indicate the current consumed by the IC only as well as by the internal power supply when the display is ON.
 fFR = 80Hz, VDD = VDD2, without n-line inversion, 1/8 bias, all internal power supply circuits are used. The internal oscillator circuit is not used. Current consumed by LCD panel capacity, wiring capacity, etc. is not included. This applies when no access is made from the MPU.

*14 Heavy load means the display pattern status when the maximum current is consumed.

9.2 Characteristics of Temperature Sensor

Table 9.8

Item	Symbol	Condition	Specified value			Unit	Applicable pin
			Min.	Typ.	Max.		
Output voltage	VSVD2	-35°C 25°C 80°C	1.430 1.164 0.907	1.475 1.200 0.935	1.519 1.236 0.963	V	SVD2 *1
Output voltage temperature gradient	VGRA	*2	—	-4.70	—	mV/°C	SVD2
Output voltage linearity	ΔVL	*3	-1.5	—	1.5	%	SVD2
Output voltage setup time	tSEN	*4	100	—	—	mS	SVD2
Operating current	ISEN	25°C	—	10	30	μA	VDD

[Reference Matters for Items marked with *]

*1 Set the load capacity CL of the sensor voltage output pin SVD2 to 100pF or below and the load resistance RL to 1MΩ or more. In order to get accurate output voltage values, do not provide with any current path between SVD2 and VSS.

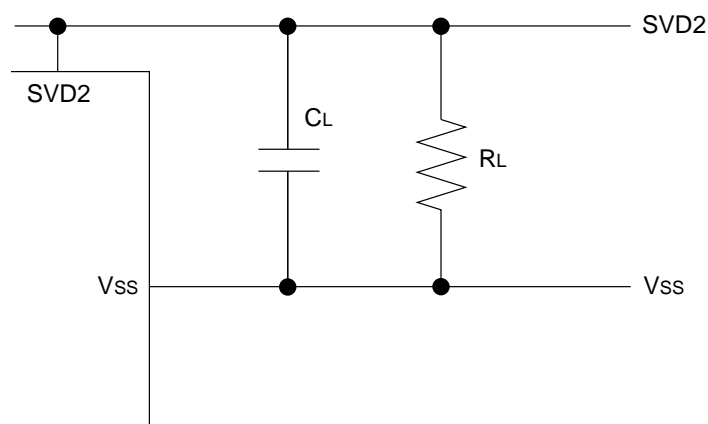

- *2 Inclination of approximate straight line of Typ. output voltage between -35°C and 80°C . See Fig. 9.6.
- *3 Maximum deviation between output voltage curve and approximate straight line. See Fig. 9.6.
 When the output voltage difference between -35°C and 85°C is ΔV_{SEN} , the difference between the approximate straight line and the output voltage linearity is $\Delta DIFF$, and the maximum value is $\Delta DIFF (MAX)$, the output voltage linearity ΔV_L is expressed by the following formula

$$\Delta V_L = \frac{\Delta DIFF (MAX)}{\Delta V_{SEN}} \times 100$$

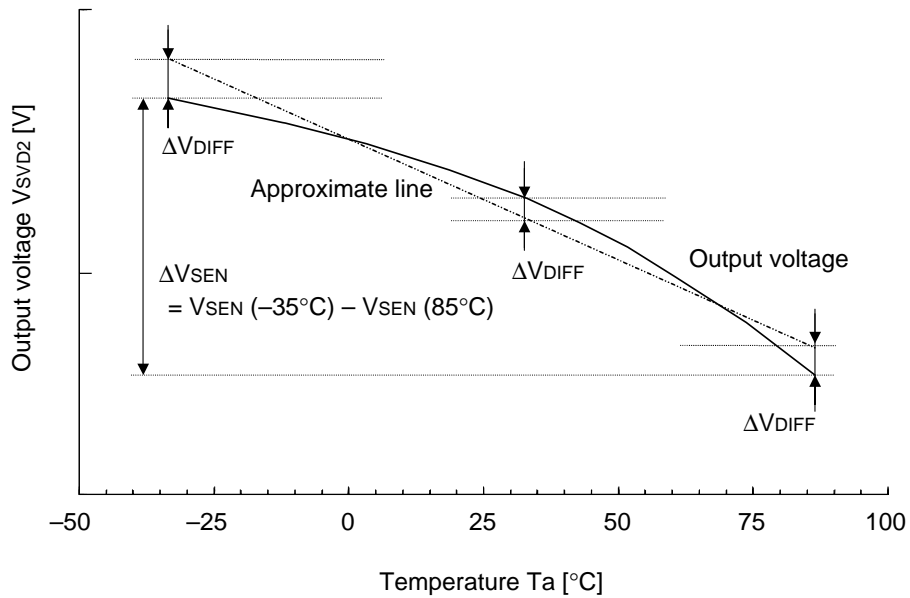

Fig. 9.6

- *4 The waiting time until the output voltage is stabilized and can be monitored after the temperature sensor ON command is input. Be sure to sample output voltages after a waiting time more than the specified one elapsed.

10. TIMING CHARACTERISTICS

(1) System path read/write characteristics 1 (80 system MPU)

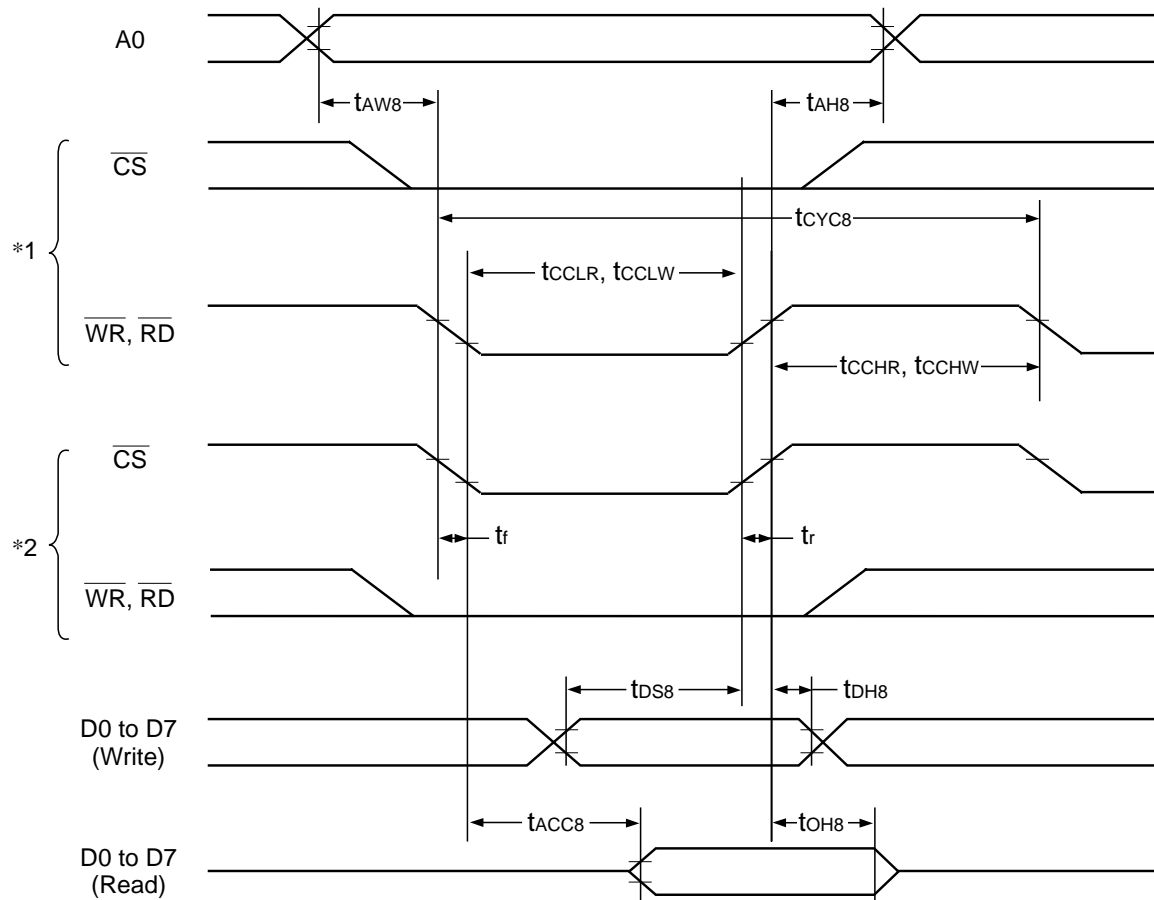

Fig. 10.1

Table 10.1

[$V_{DD} = 2.7V$ to $5.5V$, $T_a = -40$ to $+85^\circ C$]

Parameter	Signal	Symbol	Condition	Specified value		Unit
				Min.	Max.	
Address hold time	A0	t_{AH8}	—	0	—	ns
Address setup time	A0	t_{AW8}	—	0	—	
System write cycle time	\overline{WR}	t_{WCYC8}	—	500	—	
System read cycle time	\overline{RD}	t_{RCYC8}	—	7000	—	
Control LOW-pulse width (Write)	\overline{WR}	t_{CCLW}	—	200	—	
Control LOW-pulse width (Read)	\overline{RD}	t_{CCLR}	—	3000	—	
Control HIGH-pulse width (Write)	\overline{WR}	t_{CCHW}	—	200	—	
Control HIGH-pulse width (Read)	\overline{RD}	t_{CCHR}	—	200	—	
Data setup time	D0 to D7	t_{DS8}	—	200	—	
Data hold time		t_{DH8}	—	30	—	
\overline{RD} access time		t_{ACC8}	CL=100pF	—	3500	
Output disable time		t_{OH8}		5	200	

*1. This is in case of making the access by \overline{WR} and \overline{RD} , setting the $\overline{CS} = \text{LOW}$.

*2. This is in case of making the access by \overline{CS} , setting the $\overline{WR}, \overline{RD} = \text{LOW}$.

*3. Input signal rise and fall time (t_r, t_f) must not exceed 15 ns. When the system cycle time is used at a high speed, it is specified by $(t_r + t_f) \leq (t_{CYC8} - t_{CCLW} - t_{CCHW})$ or $(t_r + t_f) \leq (t_{CYC8} - t_{CCLR} - t_{CCHR})$.

*4. Timing is entirely specified with reference to 20% or 80% of V_{DD} .

*5. t_{CCLW} and t_{CCLR} are specified in terms of the overlapped period when \overline{CS} is at LOW level and \overline{WR} and \overline{RD} are at LOW level.

(2) System path read/write characteristics 2 (68 system MPU)

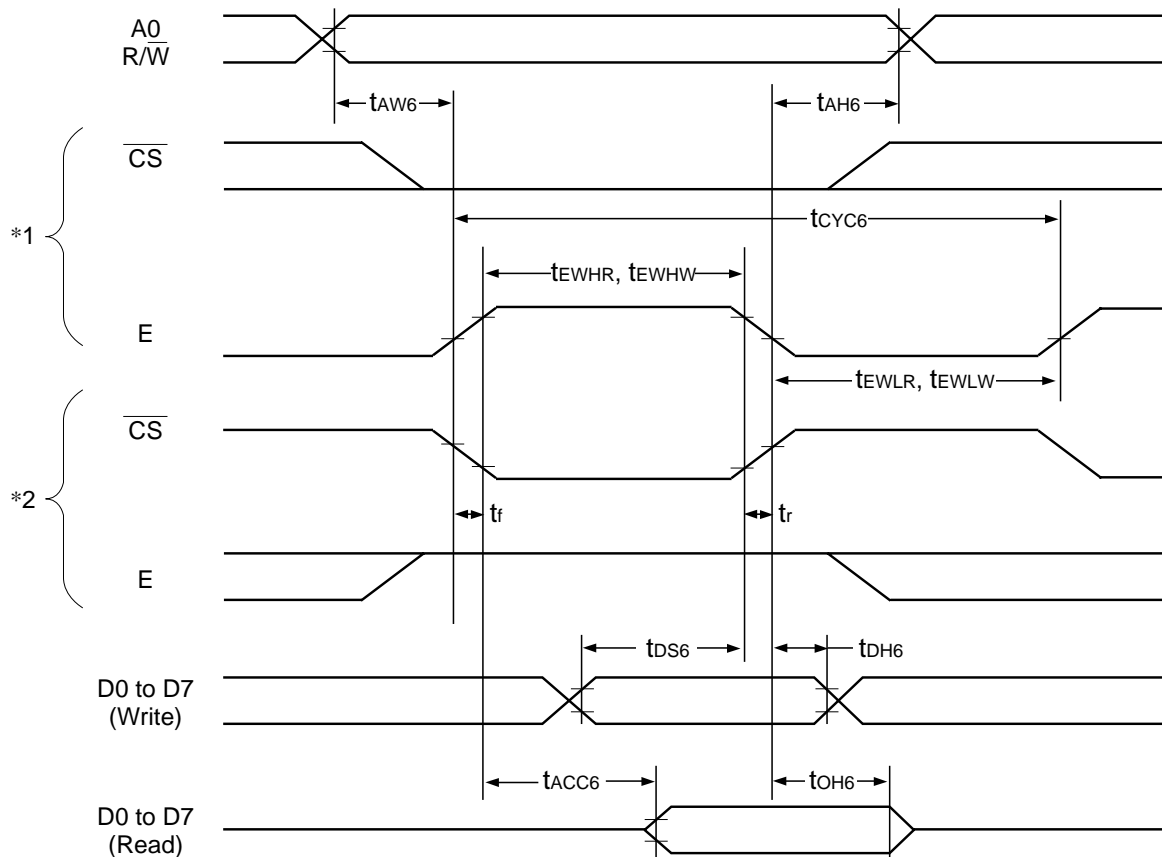

Fig. 10.2

Table 10.2

[VDD = 2.7V to 5.5V, Ta = -40 to +85°C]

Parameter	Signal	Symbol	Condition	Specified value		Unit
				Min.	Max.	
Address hold time	A0	tAH6	—	20	—	ns
Address setup time	A0	tAW6	—	0	—	
System write cycle time	E	tWCYC6	—	500	—	
System read cycle time	E	tRCYC6	—	7000	—	
Data setup time	D0 to D7	tDS6	—	200	—	
Data hold time		tDH6	—	60	—	
Access time	D0 to D7	tACC6	CL=100pF	—	3500	
Output disable time		tOH6	—	5	200	
Enable HIGH-pulse width	Read	E	—	3000	—	
Write	tEWHR			200	—	
Enable LOW-pulse width	Read	E	—	200	—	
Write	tEWLR			200	—	

*1 This is in case of making the access by E, setting the CS = LOW.
 *2 This is in case of making the access by CS, setting the E = HIGH.
 *3 The rise time and the fall time (tr & tf) of the input signals should be set to 15ns or less. When it is necessary to use the system cycle time at high speed, the rise time and the fall time should be so set to conform to (tr+tf) ≤ (tcYC6-tEWLW-tEWHW) or (tr+tf) ≤ (tcYC6-tEWLR-tEWHR).
 *4 All the timing should basically be set to 20% and 80% of the “VDD”.
 *5 tEWLW, tEWLR should be set to the overlapping zone where the CS is on the LOW level and where the E is on the HIGH level.

(3) Serial interface

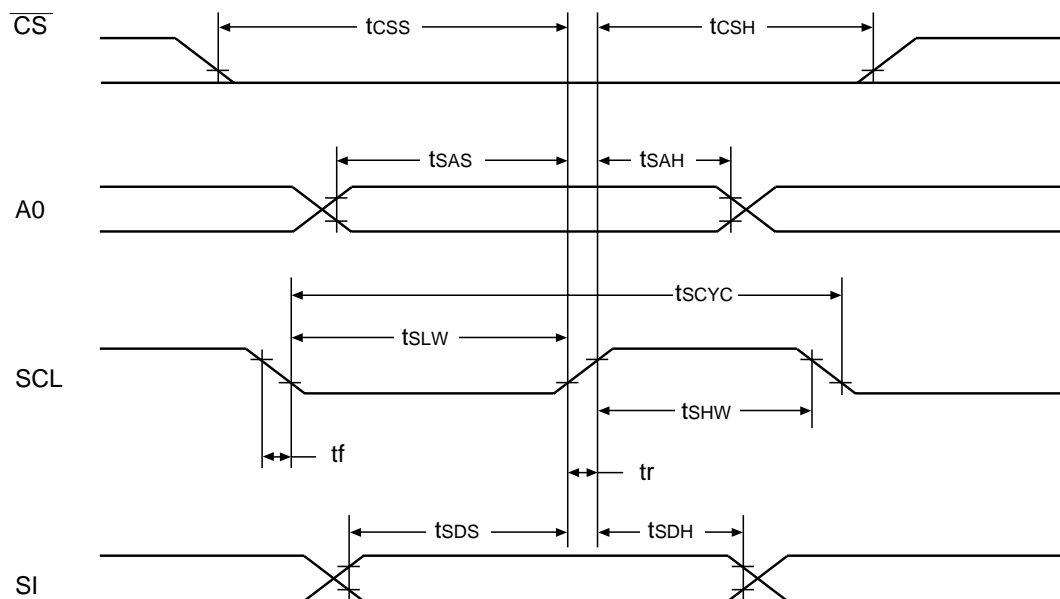

Figure 10.3

Table 10.3

[V_{DD} = 2.7V to 5.5V, T_a = -40 to +85°C]

Parameter	Signal	Symbol	Condition	Specified value		Unit
				Min.	Max.	
Serial clock period	SCL	tSCYC	—	250	—	ns
SCL HIGH pulse width		tSHW	—	100	—	
SCL LOW pulse width		tSLW	—	100	—	
Address setup time	A0	tsAS	—	150	—	
Address hold time		tSAH	—	150	—	
Data setup time	SI	tSDS	—	200	—	
Data hold time		tSDH	—	100	—	
CS-SCL time	CS	tCSS	—	150	—	
		tCSH	—	150	—	

*1. Input signal rise and fall time (tr, tf) must not exceed 15 ns.

*2. Timing is entirely specified with reference to 20% or 80% of V_{DD}.

(4) Display control input/output timing

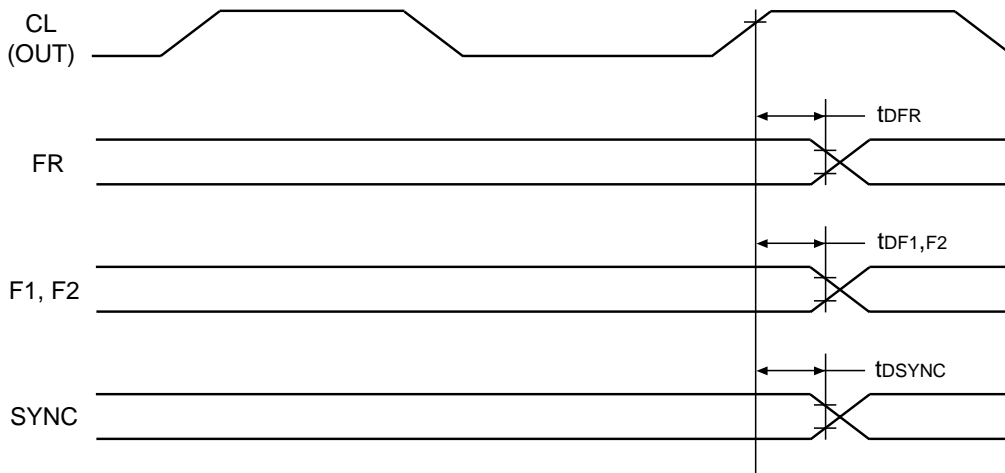

Fig. 10.4

Table 10.4 Output Timing

[VDD = 2.7V to 5.5V, Ta = -40 to +85°C]

Parameter	Signal	Symbol	Condition	Specified value			Unit
				Min.	Typ.	Max.	
FR delay time	FR	tDFR	CL = 50pF	—	60	200	ns
F1, F2 delay time	F1, F2	tDF1, tF2		—	60	200	ns
SYNC delay time	SYNC	tDSYNC		—	60	200	ns

Table 10.5 Input Timing

[VDD = 2.7V to 5.5V, Ta = -40 to +85°C]

Parameter	Signal	Symbol	Condition	Specified value			Unit
				Min.	Typ.	Max.	
FR delay time	FR	tDFR		-1.0	—	1.0	μs
F1, F2 delay time	F1, F2	tDF1, tF2		-1.0	—	1.0	μs
SYNC delay time	SYNC	tDSYNC		-1.0	—	1.0	μs
Low-level pulse width	CL	tWLCL		1.0	—	—	μs
High-level pulse width		tWHCL		1.0	—	—	μs

*1. Timing is entirely specified with reference to 20% or 80% of VDD.

(5) Reset input timing

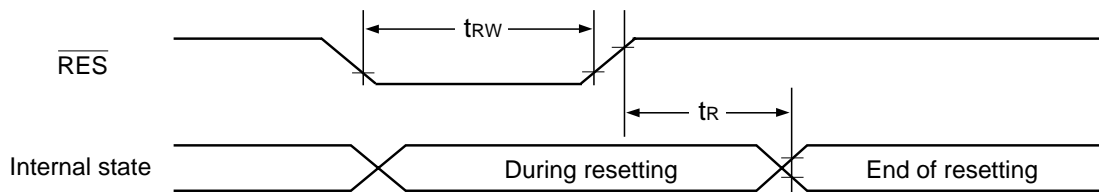

Fig. 10.5

Table 10.5

[VDD = 2.7V to 5.5V, Ta = -40 to +85°C]

Parameter	Signal	Symbol	Condition	Specified value			Unit
				Min.	Typ.	Max.	
Reset time	—	t _R	—	—	—	1000	μs
Reset LOW pulse width	RES	t _{RW}	—	1000	—	—	

*1. Timing is entirely specified with reference to 20% or 80% of VDD.

11. MPU INTERFACE

The S1D15714 Series can be connected to the 80 series MPU and 68 series MPU. Use of a serial interface allows operation with a smaller number of signal lines.

You can expand the display area using the S1D15714 Series as a multi-chip. In this case, the IC to be accesses can be selected individually by the chip select signal. After initialization by the $\overline{\text{RES}}$ pin, each input terminal of the S1D15714 Series must be placed under normal control.

(1) 80 series MPU

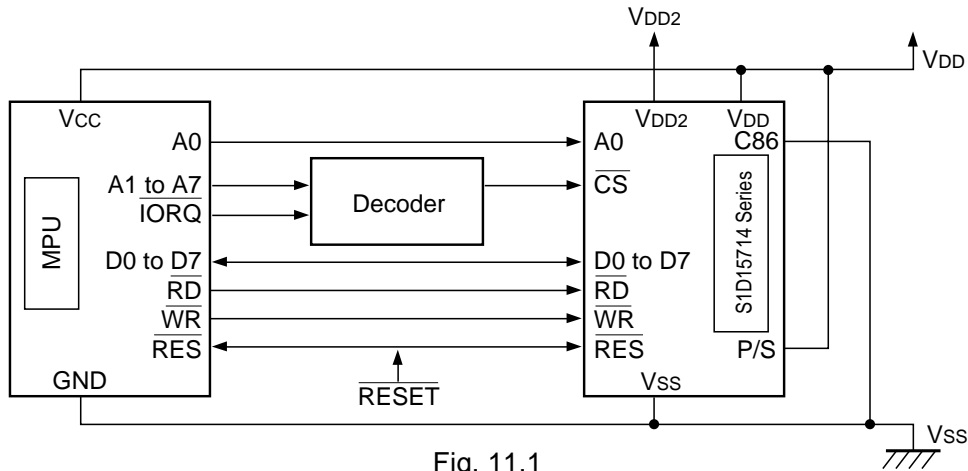

Fig. 11.1

(2) 68 series MPU

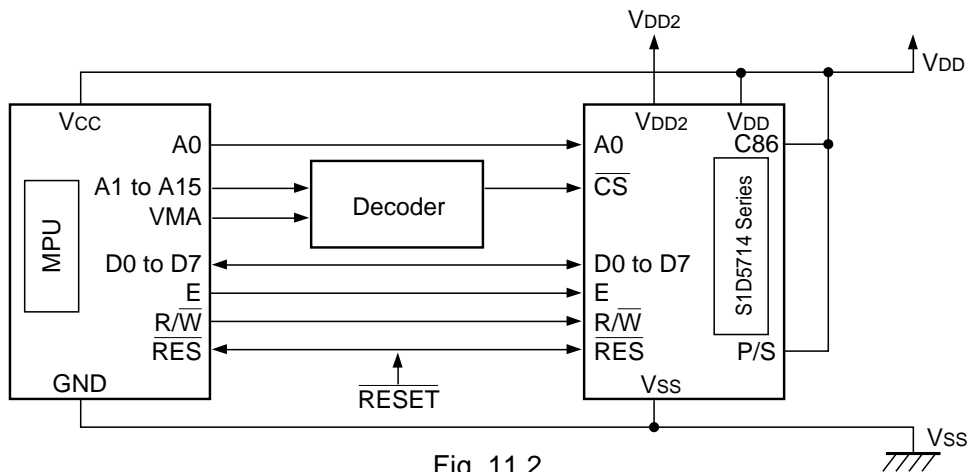

Fig. 11.2

(3) Serial interface

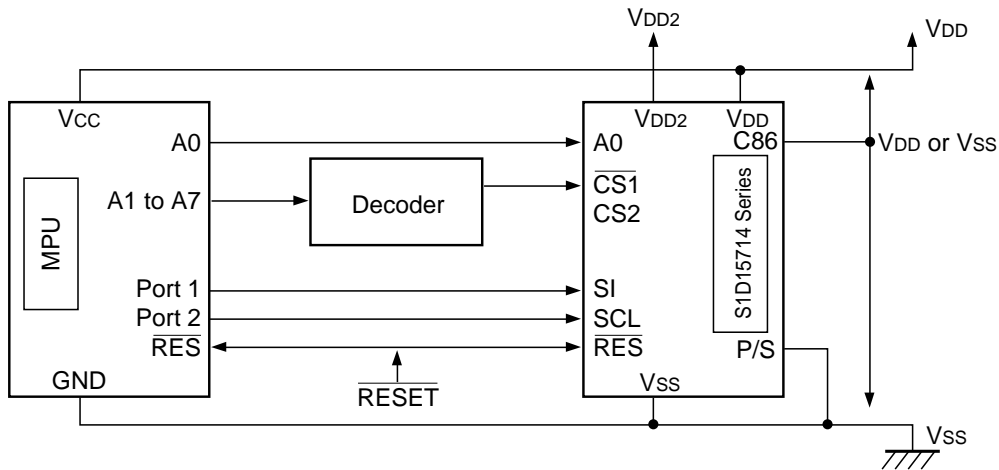

Fig. 11.3

12. CONNECTION BETWEEN LCD DRIVERS

You can easily expand the liquid crystal display area using the S1D15714 Series as a multi-chip. In this case, use the same model (S1D15714/S1D15714) as the master and slave systems.

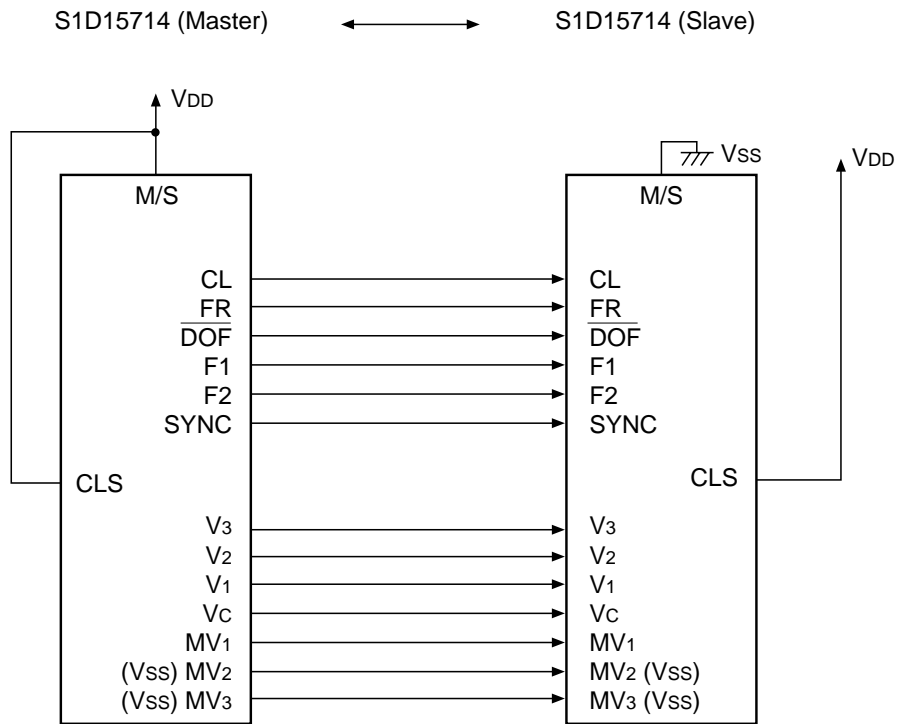

Fig. 12 Master/slave connection example

13. LCD PANEL WIRING

You can easily expand the liquid crystal display area using the S1D15714 Series as a multi-chip. In the case of multi-chip configuration, use the same models.

(1) Single chip configuration example

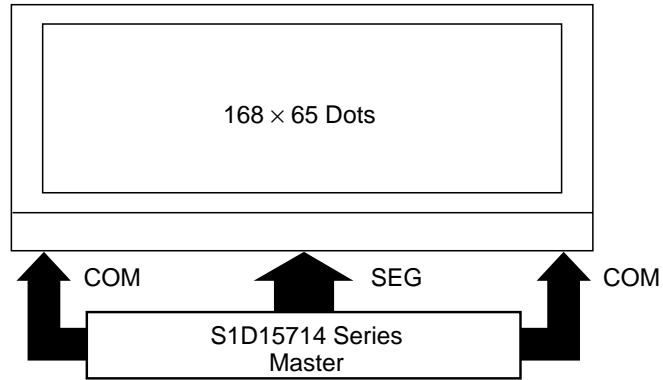

Fig. 13.1 Single chip configuration example

(2) Double chip configuration example

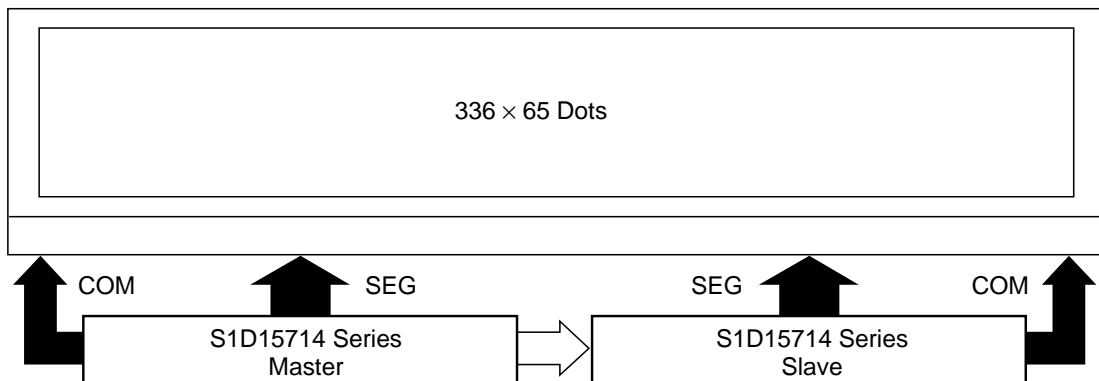

Fig. 13.2 Double chip configuration example

14. CAUTIONS

Cautions must be exercised on the following points when using this Development Specification:

1. This Development Specification is subject to change for engineering improvement.
2. This Development Specification does not guarantee execution of the industrial proprietary rights or other rights, or grant a license. Examples of applications described in This Development Specification are intended for your understanding of the Product. We are not responsible for any circuit problem or the like arising from the use of them.
3. Reproduction or copy of any part or whole of this Development Specification without permission of our company, or use thereof for other business purposes is strictly prohibited.

For the use of the semi-conductor,cautions must be exercised on the following points:

[Cautions against Light]

The semiconductor will be subject to changes in characteristics when light is applied. If this IC is exposed to light, operation error may occur. To protect the IC against light, the following points should be noted regarding the substrate or product where this IC is mounted:

- (1) Designing and mounting must be provided to get a structure which ensures a sufficient resistance of the IC to light in practical use.
- (2) In the inspection process, environmental configuration must be provided to ensure a sufficient resistance of the IC to light.
- (3) Means must be taken to ensure resistance to light on all the surfaces, backs and sides of the IC

S1D15714 Series

SEIKO EPSON CORPORATION
ELECTRONIC DEVICES MARKETING DIVISION