

SK 40GB123

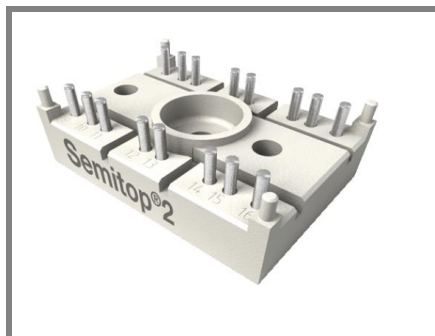

SEMİTOP® 2

IGBT Module

SK 40GB123

Preliminary Data

Features

- Compact design
- One screw mounting
- Heat transfer and isolation through direct copper bonded aluminium oxide ceramic (DCB)
- N-channel homogeneous silicon structure (NPT-Non punch-through IGBT)
- Low tail current with low temperature dependence

Typical Applications

- Switching (not for linear use)
- Inverter
- Switched mode power supplies
- UPS

Remarks

- V_F = chip level value

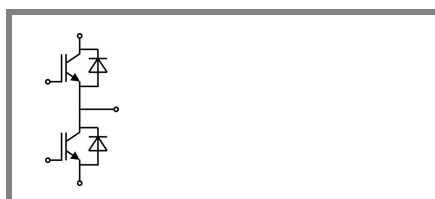

GB

Absolute Maximum Ratings		$T_s = 25\text{ °C}$, unless otherwise specified			
Symbol	Conditions	Values			Units
IGBT					
V_{CES}	$T_j = 25\text{ °C}$	1200			V
I_C	$T_j = 125\text{ °C}$	$T_s = 25\text{ °C}$	40		A
		$T_s = 80\text{ °C}$	27		A
I_{CRM}	$I_{CRM} = 2 \times I_{Cnom}$	60			A
V_{GES}		± 20			V
t_{psc}	$V_{CC} = 600\text{ V}; V_{GE} \leq 20\text{ V}; T_j = 125\text{ °C}$ $V_{CES} < 1200\text{ V}$	10			μs
Inverse Diode					
I_F	$T_j = 150\text{ °C}$	$T_s = 25\text{ °C}$	48		A
		$T_s = 80\text{ °C}$	34		A
I_{FRM}	$I_{FRM} = 2 \times I_{Fnom}$	60			A
Module					
$I_{t(RMS)}$					A
T_{vj}		-40 ... +150			$^{\circ}\text{C}$
T_{stg}		-40 ... +125			$^{\circ}\text{C}$
V_{isol}	AC, 1 min.	2500			V

Characteristics		$T_s = 25\text{ °C}$, unless otherwise specified				
Symbol	Conditions	min.	typ.	max.	Units	
IGBT						
$V_{GE(th)}$	$V_{GE} = V_{CE}, I_C = 1,2\text{ mA}$	4,5	5,5	6,5	V	
I_{CES}	$V_{GE} = 30\text{ V}, V_{CE} = V_{CES}$	$T_j = 25\text{ °C}$			0,2	mA
		$T_j = 125\text{ °C}$				mA
I_{GES}	$V_{CE} = 0\text{ V}, V_{GE} = 30\text{ V}$	$T_j = 25\text{ °C}$			560	nA
		$T_j = 125\text{ °C}$				nA
V_{CE0}		$T_j = 25\text{ °C}$	1,2		V	
		$T_j = 125\text{ °C}$	1,2		V	
r_{CE}	$V_{GE} = 15\text{ V}$	$T_j = 25\text{ °C}$	43		$\text{m}\Omega$	
		$T_j = 125\text{ °C}$	63		$\text{m}\Omega$	
$V_{CE(sat)}$	$I_{Cnom} = 30\text{ A}, V_{GE} = 15\text{ V}$	$T_j = 25\text{ °C}_{chiplev.}$	2	2,5	3	V
		$T_j = 125\text{ °C}_{chiplev.}$		3,1	3,7	V
C_{ies}	$V_{CE} = 25, V_{GE} = 0\text{ V}$	$f = 1\text{ MHz}$	2		nF	
C_{oes}			0,3		nF	
C_{res}			0,14		nF	
$t_{d(on)}$	$R_{Gon} = 20\ \Omega$	$V_{CC} = 600\text{ V}$ $I_{Cnom} = 30\text{ A}$	35		ns	
t_r			45		ns	
E_{on}	$R_{Goff} = 20\ \Omega$	$T_j = 125\text{ °C}$ $V_{GE} = \pm 15\text{ V}$	3,2		mJ	
$t_{d(off)}$			250		ns	
t_f			45		ns	
E_{off}			3,6		mJ	
$R_{th(j-s)}$	per IGBT	0,85			K/W	

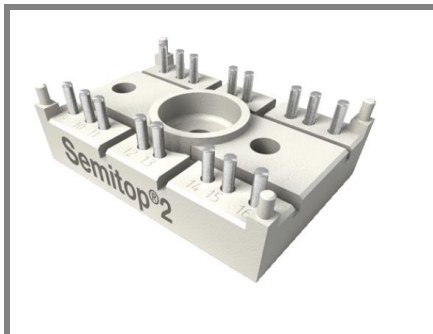

SEMITOP[®] 2

IGBT Module

SK 40GB123

Preliminary Data

Features

- Compact design
- One screw mounting
- Heat transfer and isolation through direct copper bonded aluminium oxide ceramic (DCB)
- N-channel homogeneous silicon structure (NPT-Non punch-through IGBT)
- Low tail current with low temperature dependence

Typical Applications

- Switching (not for linear use)
- Inverter
- Switched mode power supplies
- UPS

Remarks

- V_F = chip level value



GB

Characteristics

Symbol	Conditions	min.	typ.	max.	Units
Inverse Diode					
$V_F = V_{EC}$	$I_{Fnom} = 30 \text{ A}; V_{GE} = 0 \text{ V}$		2		V
			1,8		V
					$T_j = 25 \text{ }^\circ\text{C}_{\text{chiplev.}}$
					$T_j = 125 \text{ }^\circ\text{C}_{\text{chiplev.}}$
V_{F0}			1	1,2	V
r_F			53	73	m Ω
					$T_j = 125 \text{ }^\circ\text{C}$
I_{RRM}	$I_{Fnom} = 30 \text{ A}$		32		A
Q_{rr}	$di/dt = 400 \text{ A}/\mu\text{s}$		5,4		μC
E_{rr}	$V_{CC} = 600\text{V}$		1,2		mJ
$R_{th(j-s)D}$	per diode			1	K/W
M_s	to heat sink M1			2	Nm
w			21		g

This is an electrostatic discharge sensitive device (ESDS), international standard IEC 60747-1, Chapter IX.

This technical information specifies semiconductor devices but promises no characteristics. No warranty or guarantee expressed or implied is made regarding delivery, performance or suitability.

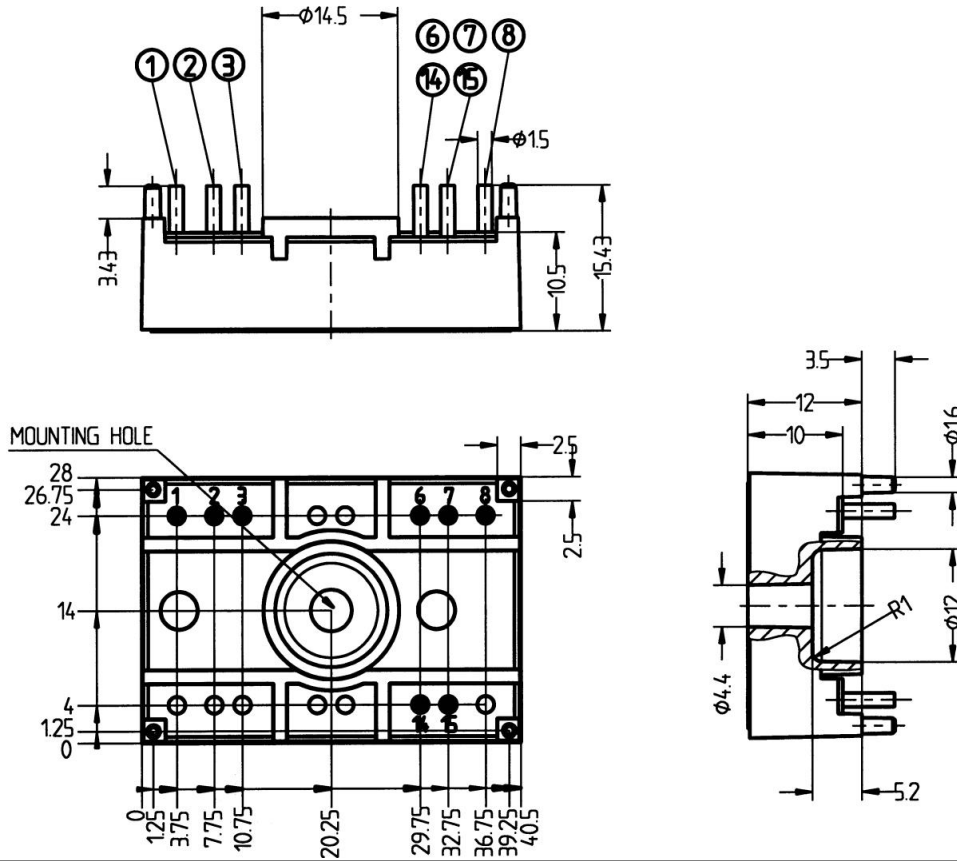

Case T32 (Suggested hole diameter, in the PCB, for solder pins and plastic mounting pins: 2mm)

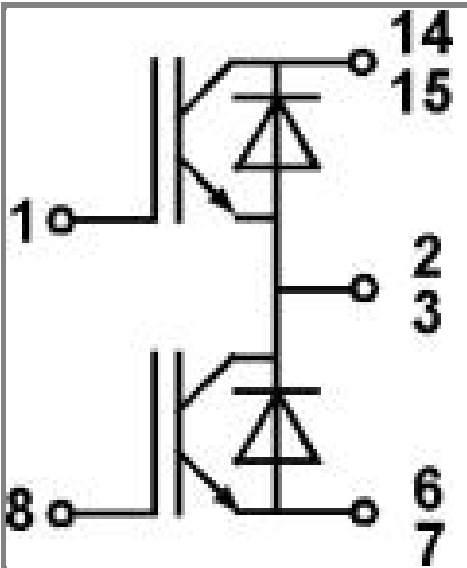

Case T32

GB