

SIMMIC 50-860 MHz FREQUENCY UPCONVERTER

UPC2799

FEATURES

- 50-860 MHz RF FREQUENCY RANGE
- 50-1800 MHz LO RANGE
- 15 dB VARIABLE GAIN RF AMP
- +5 dB dBm IIP3 MIXER
- 8 dB RF CONVERSION GAIN
- BUFFERED LO OUTPUT

DESCRIPTION AND APPLICATIONS

The UHF Band frequency converter is manufactured using the (Ft 20 GHz) NESAT III process . This 5V IC consists of a RF Gain control amplifier, linear, Gilbert cell mixer, two stages of LO buffering, local oscillator, external filter port, and a temperature compensation circuit. This device was specifically designed for CATV, Modems, HFC Telephony and other Multimedia applications.

NEC's stringent quality assurance and test procedures assure the highest reliability and performance.

INTERNAL BLOCK DIAGRAM

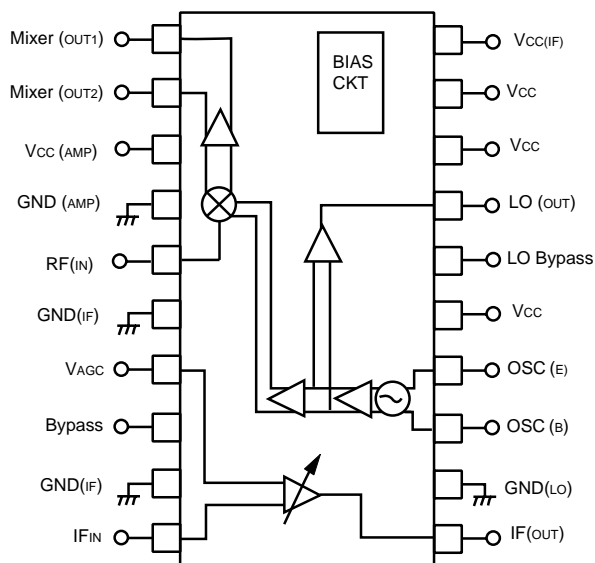

ELECTRICAL CHARACTERISTICS (TA = 25°C)

PARAMETERS	SYMBOLS	CONDITIONS	MIN	TYP	MAX	UNITS
Supply Voltage	VCC		4.5	5	5.5	V
Current	ICC			41		mA
MIXER SECTION						
Input Return Loss	RLIN	w/external match		10		dB
RF Input Frequency	RF		50		860	MHz
LO Frequency	LO				1800	MHz
Gain Flatness	GF	6 MHz		.25		dB
Noise Figure 750MHz	NF	Measured at mixer output			12	dB
Input IP3	IIP3	Measured at mixer output	+3	+5		dBm
Conv. Gain MIXER	Gc			8		dB

*The information contained in this document is being issued in advance of the production cycle for the device. The parameters for the device may change before final production or NEC Corporation, at its own discretion, may withdraw the device prior to its production.

ELECTRICAL CHARACTERISTICS (T_A = 25°C)

PARAMETERS	SYMBOLS	CONDITIONS	MIN	TYP	MAX	UNITS
LO SECTION						
LO Tuning Range	LO		700	800		MHz
SSB Phase Noise		10 KHz offset		-85		dBc/Hz
LO Spurious				-40		dBc
RF to LO ISOL	RF-LO			-50		dBm
LO to RF Leak	LO-RF		40	-45		dBm
LO to IF Leak	LO-IF			-20		dBm
LO Buffered Output				-15		dBm
RF AMPLIFIER SECTION						
RF _{INPUT} RL	Input RL	w/ external match		10		dB
RF Bandwidth	RFBW		45		900	MHz
RF Flatness	dB	6 MHz BW	-0.3		+0.3	dB
RF Gain Range			3		15	dB
Output IP3		Min Gain		+15		dBm
Noise Figure		Max Gain		6.0	7.0	dB

*Dependent on external tuning circuit

(1) Indicate whether specification is for internal use only.

OUTLINE DIMENSIONS (Units in mm)

PACKAGE OUTLINE 20 PIN SSOP

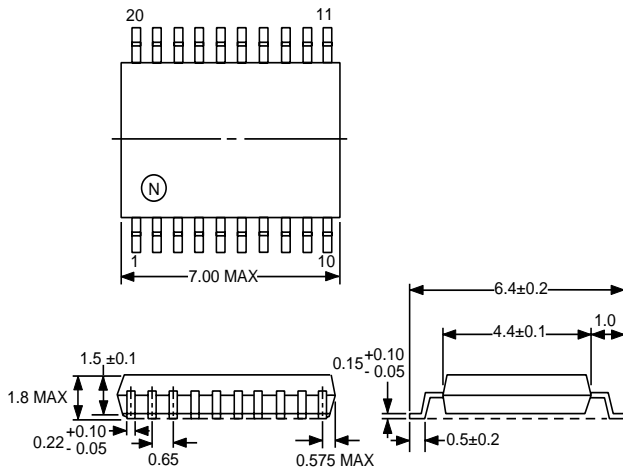

Lead Material: Alloy 42
Lead Plating: Lead Tin Alloy\

PIN CONNECTIONS

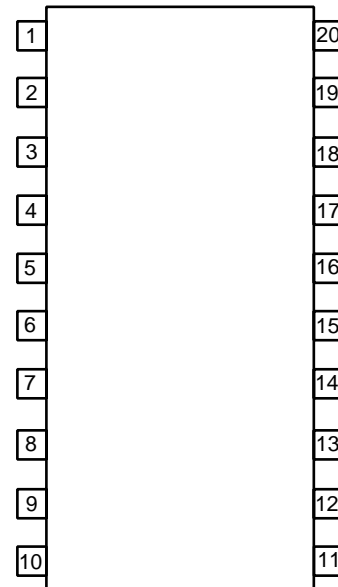

PIN CONNECTIONS:

- | | |
|------------------|--------------|
| 1. Mixer (Out1) | 20. Vcc (IF) |
| 2. Mixer (Out 2) | 19. Vcc |
| 3. Vcc (AMP) | 18. Vcc |
| 4. GND(AMP) | 17. LO OUT |
| 5. RF (IN) | 16. LO(B) |
| 6. GND (IF) | 15. Vcc |
| 7. VAGC | 14. OSC (E) |
| 8. Bypass | 13. OCS (B) |
| 9. GND (IF) | 12. GND (LO) |
| 10. IF (IN) | 11. IF (OUT) |