



- Table of Contents -

1. General Description	2
2. Features	2
3. Pin Description	2
4. Pad Diagram	3
5. Pad Coordination	3
6. LCD Display RAM Map	4
6.1. 16 Gray Scale LCD Display RAM Map	5
6.2. 4 Gray Scale LCD Display RAM Map	12
6.3. Black and White LCD Display RAM Map	15
7. Command Interface	17
8. Timing Diagram	19
9. Absolute Maximum Rating	20
10. Recommended Operating Conditions	20
11. AC/DC Characteristics	20
12. Application Circuit	22
13. Updated History	24

1. General Description

KD83 is a gray-scale LCD Segment Extender which, when used with KB's MCU with LCD Segment Extender interface, can expand the capacity of LCD driver. It is a 16 gray-scale, 4 gray-scale, and black and white LCD Segment Driver. This chip interfaces with KB's MCU with provisions of Segment Extender Interface LFR and CCK. KB's MCUs control KD83 through a command interface. The MCU can read/write display patterns to graphic mode display RAM by first setting up the target address, selecting the driver configuration, and then enabling the driver. KD83 can support five different LCD configurations: 16, 32, 48, 64 and 80 COM selectable by command register. The KD83 uses some of the memory as display RAM, while the memory not used for display can be access as general-purpose memory.

2. Features

- ✓ Graphic mode Gray-scale LCD Display 80 segment Extender.
- ✓ Command mode interface.
- ✓ Support 16 gray scale, 4 gray scale and Black/White LCD display.
- ✓ 5 LCD Configurations: 16, 32, 48, 64, or 80 COM LCD.
- ✓ Operating Range: 2.4V ~ 3.6V
- ✓ Dual Port display RAM: 5K Bytes
- ✓ Spare RAM for general purpose.

3. Pin Description

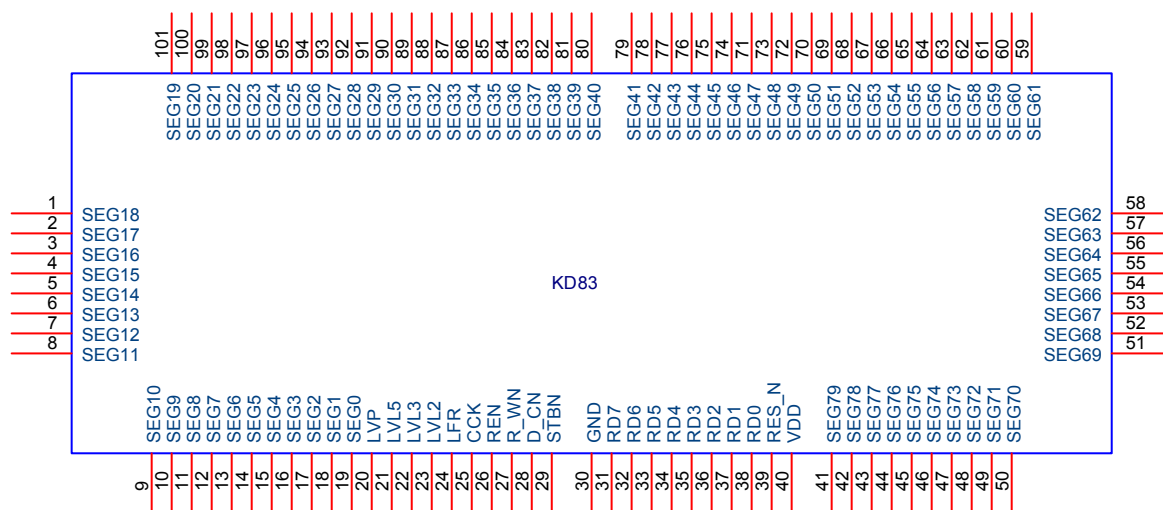

Pin Name	Pin #	I/O	Description
SEG[79..0]	41~101, 1~19	O	LCD Segment Outputs.
LVP	20	I	Charge Pump Output. These input pins must wire with master IC respectively. That means LVP with LVP, LVL5 with LVL5, ..., LDL with LDL. Please refer to application circuit.
LVL5	21	I	LCD Bias Voltage 5
LVL3	22	I	LCD Bias Voltage 3
LVL2	23	I	LCD Bias Voltage 2
LFR	24	I	LCD frame.

CCK	25	I	LCD data load
REN	26	I	Low active Enable control for data or command register read/write.
R_WN	27	I	Read(1)/write(0) mode selection.
D_CN	28	I	Data(1)/Command(0) mode selection.
STBN	29	I	Active Low R/W strobe for data or command.
GND	30	P	Power Ground Input.
RD[7:0]	31~38	B	8-bit bi-directional Command/Data bus with CMOS input structure.
RES_N	39	I	Active low Reset input.
VDD	40	P	Positive power supply input. 0.1 μ F by-pass capacitor should be added between VDD and GND and placed close to the chip is necessary.

4. Pad Diagram

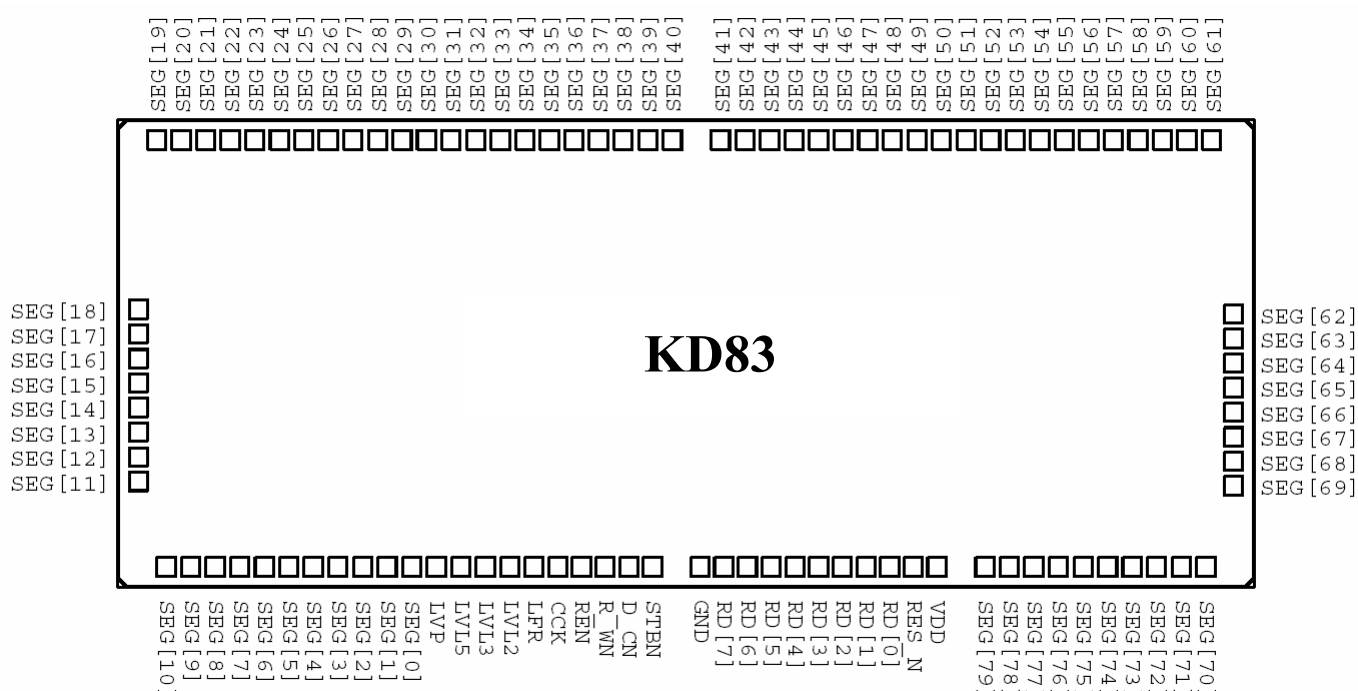

5. Pad Coordination

No.	Pad Name	X-Coord.	Y-Coord.	No.	Pad Name	X-Coord.	Y-Coord.
1	SEG[18]	-2643	150.65	52	SEG[68]	2483.45	-560.05
2	SEG[17]	-2643	35.65	53	SEG[67]	2483.45	-445.05
3	SEG[16]	-2643	-79.35	54	SEG[66]	2483.45	-330.05
4	SEG[15]	-2643	-194.35	55	SEG[65]	2483.45	-215.05
5	SEG[14]	-2643	-309.35	56	SEG[64]	2483.45	-100.05
6	SEG[13]	-2643	-424.35	57	SEG[63]	2483.45	14.95
7	SEG[12]	-2643	-539.35	58	SEG[62]	2483.45	129.95
8	SEG[11]	-2643	-654.35	59	SEG[61]	2381.3	942.1
9	SEG[10]	-2514.7	-1053.7	60	SEG[60]	2266.3	942.1
10	SEG[9]	-2399.7	-1053.7	61	SEG[59]	2151.3	942.1
11	SEG[8]	-2284.7	-1053.7	62	SEG[58]	2036.3	942.1
12	SEG[7]	-2169.7	-1053.7	63	SEG[57]	1921.3	942.1
13	SEG[6]	-2054.7	-1053.7	64	SEG[56]	1806.3	942.1



No.	Pad Name	X-Coord.	Y-Coord.	No.	Pad Name	X-Coord.	Y-Coord.
14	SEG[5]	-1939.7	-1053.7	65	SEG[55]	1691.3	942.1
15	SEG[4]	-1824.7	-1053.7	66	SEG[54]	1576.3	942.1
16	SEG[3]	-1709.7	-1053.7	67	SEG[53]	1461.3	942.1
17	SEG[2]	-1594.7	-1053.7	68	SEG[52]	1346.3	942.1
18	SEG[1]	-1479.7	-1053.7	69	SEG[51]	1231.3	942.1
19	SEG[0]	-1364.7	-1053.7	70	SEG[50]	1116.3	942.1
20	LVP	-1249.7	-1053.7	71	SEG[49]	1001.3	942.1
21	LVL5	-1134.7	-1053.7	72	SEG[48]	886.3	942.1
22	LVL3	-1019.7	-1053.7	73	SEG[47]	771.3	942.1
23	LVL2	-904.7	-1053.7	74	SEG[46]	656.3	942.1
24	LFR	-791.7	-1053.7	75	SEG[45]	541.3	942.1
25	CCK	-680.7	-1053.7	76	SEG[44]	426.3	942.1
26	REN	-569.7	-1053.7	77	SEG[43]	311.3	942.1
27	R_WN	-458.7	-1053.7	78	SEG[42]	196.3	942.1
28	D_CN	-347.7	-1053.7	79	SEG[41]	81.3	942.1
29	STBN	-236.7	-1053.7	80	SEG[40]	-144.7	942.1
30	GND	-14.7	-1053.7	81	SEG[39]	-259.7	942.1
31	RD[7]	96.3	-1053.7	82	SEG[38]	-374.7	942.1
32	RD[6]	207.3	-1053.7	83	SEG[37]	-489.7	942.1
33	RD[5]	318.3	-1053.7	84	SEG[36]	-604.7	942.1
34	RD[4]	429.3	-1053.7	85	SEG[35]	-719.7	942.1
35	RD[3]	540.3	-1053.7	86	SEG[34]	-834.7	942.1
36	RD[2]	651.3	-1053.7	87	SEG[33]	-949.7	942.1
37	RD[1]	762.3	-1053.7	88	SEG[32]	-1064.7	942.1
38	RD[0]	873.3	-1053.7	89	SEG[31]	-1179.7	942.1
39	RES_N	984.3	-1053.7	90	SEG[30]	-1294.7	942.1
40	VDD	1095.3	-1053.7	91	SEG[29]	-1409.7	942.1
41	SEG[79]	1319.3	-1053.7	92	SEG[28]	-1524.7	942.1
42	SEG[78]	1434.3	-1053.7	93	SEG[27]	-1639.7	942.1
43	SEG[77]	1549.3	-1053.7	94	SEG[26]	-1754.7	942.1
44	SEG[76]	1664.3	-1053.7	95	SEG[25]	-1869.7	942.1
45	SEG[75]	1779.3	-1053.7	96	SEG[24]	-1984.7	942.1
46	SEG[74]	1894.3	-1053.7	97	SEG[23]	-2099.7	942.1
47	SEG[73]	2009.3	-1053.7	98	SEG[22]	-2214.7	942.1
48	SEG[72]	2124.3	-1053.7	99	SEG[21]	-2329.7	942.1
49	SEG[71]	2239.3	-1053.7	100	SEG[20]	-2444.7	942.1
50	SEG[70]	2354.3	-1053.7	101	SEG[19]	-2559.7	942.1
51	SEG[69]	2483.45	-675.05				

6. LCD Display RAM Map

The gray-scale LCD driver can be configured to be a 16 gray-scales, 4 gray-scales or black and white display by programming GRAY_MODE field of command register. For 4 gray-scale displays, 2-bit of RAM is required for each pixel and 4 bit for 16 gray-scale display, 1-bit for black and white display. For different LCD configuration, the LCD display RAM is arranged differently. The following figure shows



one byte of RAM in different LCD configurations:

0F	0E	0D	0C	0B	0A	09	08	07	06	05	04	03	02	01	00
XX	XX	XX	XX	XX	XX	XX	XX	XX	XX	XX	XX	XX	XX	XX	XX

	Bit 7	Bit 6	Bit 5	Bit 4	Bit 3	Bit 2	Bit 1	Bit 0
Black/White	SEG7	SEG6	SEG5	SEG4	SEG3	SEG2	SEG1	SEG0
4 Gray scales	SEG3		SEG2		SEG1		SEG0	
16 Gray scales	SEG1				SEG0			

The 16 Gray Scale register GRAY0 ~ GRAYF is the mapping register between the levels selected in RAM and the real gray scale. In other words, if the content of GRAY0 is 0x03, when value of a certain pixel is 0, the displayed effect will correspond to actual gray level 3. The 16 gray scale display use all 16 registers GRAY0 ~ GRAYF to select among 32 available gray levels to correspond to level 0 ~ 15, while 4 gray scale display utilizes registers GRAY0 ~ GRAY3 to select among 32 gray levels to correspond to level 0 ~ 3. Thus user can pick the gray levels which give the best and most linear effect.

6.1. 16 Gray Scale LCD Display RAM Map

16 Gray Levels LCD Display RAM MAP										
Page		F	C	B	8	7	4	3	0	COM No.
0	00	S31~S24	S23~S16	S15~S08	S07~S00	COM0				
	10	S63~S56	S55~S48	S47~S40	S39~S32					
	20	*	*	S79~S72	S71~S64					
	30	*	*	*	*					
	40	S31~S24	S23~S16	S15~S08	S07~S00	COM1				
	50	S63~S56	S55~S48	S47~S40	S39~S32					
	60	*	*	S79~S72	S71~S64					
	70	*	*	*	*					
	80	S31~S24	S23~S16	S15~S08	S07~S00	COM2				
	90	S63~S56	S55~S48	S47~S40	S39~S32					
	A0	*	*	S79~S72	S71~S64					
	B0	*	*	*	*					
	C0	S31~S24	S23~S16	S15~S08	S07~S00	COM3				
	D0	S63~S56	S55~S48	S47~S40	S39~S32					
	E0	*	*	S79~S72	S71~S64					
	F0	*	*	*	*					
1	00	S31~S24	S23~S16	S15~S08	S07~S00	COM4				
	10	S63~S56	S55~S48	S47~S40	S39~S32					
	20	*	*	S79~S72	S71~S64					
	30	*	*	*	*					
	40	S31~S24	S23~S16	S15~S08	S07~S00	COM5				
	50	S63~S56	S55~S48	S47~S40	S39~S32					
	60	*	*	S79~S72	S71~S64					
70	*	*	*	*						



16 Gray Levels LCD Display RAM MAP										
Page		F	C	B	8	7	4	3	0	COM No.
	80	S31~S24	S23~S16	S15~S08	S07~S00	COM6				
	90	S63~S56	S55~S48	S47~S40	S39~S32					
	A0	*	*	S79~S72	S71~S64					
	B0	*	*	*	*					
	C0	S31~S24	S23~S16	S15~S08	S07~S00		COM7			
	D0	S63~S56	S55~S48	S47~S40	S39~S32					
	E0	*	*	S79~S72	S71~S64					
	F0	*	*	*	*					
2	00	S31~S24	S23~S16	S15~S08	S07~S00	COM8				
	10	S63~S56	S55~S48	S47~S40	S39~S32					
	20	*	*	S79~S72	S71~S64					
	30	*	*	*	*					
	40	S31~S24	S23~S16	S15~S08	S07~S00	COM9				
	50	S63~S56	S55~S48	S47~S40	S39~S32					
	60	*	*	S79~S72	S71~S64					
	70	*	*	*	*					
	80	S31~S24	S23~S16	S15~S08	S07~S00	COM10				
	90	S63~S56	S55~S48	S47~S40	S39~S32					
	A0	*	*	S79~S72	S71~S64					
	B0	*	*	*	*					
	C0	S31~S24	S23~S16	S15~S08	S07~S00	COM11				
	D0	S63~S56	S55~S48	S47~S40	S39~S32					
	E0	*	*	S79~S72	S71~S64					
	F0	*	*	*	*					
3	00	S31~S24	S23~S16	S15~S08	S07~S00	COM12				
	10	S63~S56	S55~S48	S47~S40	S39~S32					
	20	*	*	S79~S72	S71~S64					
	30	*	*	*	*					
	40	S31~S24	S23~S16	S15~S08	S07~S00	COM13				
	50	S63~S56	S55~S48	S47~S40	S39~S32					
	60	*	*	S79~S72	S71~S64					
	70	*	*	*	*					
	80	S31~S24	S23~S16	S15~S08	S07~S00	COM14				
	90	S63~S56	S55~S48	S47~S40	S39~S32					
	A0	*	*	S79~S72	S71~S64					
	B0	*	*	*	*					
	C0	S31~S24	S23~S16	S15~S08	S07~S00	COM15				
	D0	S63~S56	S55~S48	S47~S40	S39~S32					
	E0	*	*	S79~S72	S71~S64					
	F0	*	*	*	*					
4	00	S31~S24	S23~S16	S15~S08	S07~S00	COM16				
	10	S63~S56	S55~S48	S47~S40	S39~S32					
	20	*	*	S79~S72	S71~S64					
	30	*	*	*	*					
	40	S31~S24	S23~S16	S15~S08	S07~S00	COM17				
	50	S63~S56	S55~S48	S47~S40	S39~S32					
	60	*	*	S79~S72	S71~S64					



16 Gray Levels LCD Display RAM MAP											
Page		F	C	B	8	7	4	3	0	COM No.	
	70	*		*		*		*			
	80	S31~S24		S23~S16		S15~S08		S07~S00		COM18	
	90	S63~S56		S55~S48		S47~S40		S39~S32			
	A0	*		*		S79~S72		S71~S64			
	B0	*		*		*		*			
		C0	S31~S24		S23~S16		S15~S08		S07~S00		COM19
		D0	S63~S56		S55~S48		S47~S40		S39~S32		
		E0	*		*		S79~S72		S71~S64		
F0		*		*		*		*			
5		00	S31~S24		S23~S16		S15~S08		S07~S00		COM20
		10	S63~S56		S55~S48		S47~S40		S39~S32		
		20	*		*		S79~S72		S71~S64		
		30	*		*		*		*		
	COM21	40	S31~S24		S23~S16		S15~S08		S07~S00		
		50	S63~S56		S55~S48		S47~S40		S39~S32		
		60	*		*		S79~S72		S71~S64		
		70	*		*		*		*		
	COM22	80	S31~S24		S23~S16		S15~S08		S07~S00		
		90	S63~S56		S55~S48		S47~S40		S39~S32		
		A0	*		*		S79~S72		S71~S64		
		B0	*		*		*		*		
		COM23	C0	S31~S24		S23~S16		S15~S08		S07~S00	
			D0	S63~S56		S55~S48		S47~S40		S39~S32	
			E0	*		*		S79~S72		S71~S64	
			F0	*		*		*		*	
6	00	S31~S24		S23~S16		S15~S08		S07~S00		COM24	
	10	S63~S56		S55~S48		S47~S40		S39~S32			
	20	*		*		S79~S72		S71~S64			
	30	*		*		*		*			
	COM25	40	S31~S24		S23~S16		S15~S08		S07~S00		
		50	S63~S56		S55~S48		S47~S40		S39~S32		
		60	*		*		S79~S72		S71~S64		
		70	*		*		*		*		
	COM26	80	S31~S24		S23~S16		S15~S08		S07~S00		
		90	S63~S56		S55~S48		S47~S40		S39~S32		
		A0	*		*		S79~S72		S71~S64		
		B0	*		*		*		*		
		COM27	C0	S31~S24		S23~S16		S15~S08		S07~S00	
			D0	S63~S56		S55~S48		S47~S40		S39~S32	
			E0	*		*		S79~S72		S71~S64	
			F0	*		*		*		*	
7	00	S31~S24		S23~S16		S15~S08		S07~S00		COM28	
	10	S63~S56		S55~S48		S47~S40		S39~S32			
	20	*		*		S79~S72		S71~S64			
	30	*		*		*		*			
	COM29	40	S31~S24		S23~S16		S15~S08		S07~S00		
		50	S63~S56		S55~S48		S47~S40		S39~S32		



16 Gray Levels LCD Display RAM MAP											
Page		F	C	B	8	7	4	3	0	COM No.	
	60	*		*		S79~S72		S71~S64		COM30	
	70	*		*		*		*			
	80	S31~S24		S23~S16		S15~S08		S07~S00			
	90	S63~S56		S55~S48		S47~S40		S39~S32			
	A0	*		*		S79~S72		S71~S64			
		B0	*		*		*		*	COM31	
		C0	S31~S24		S23~S16		S15~S08		S07~S00		
		D0	S63~S56		S55~S48		S47~S40		S39~S32		
		E0	*		*		S79~S72		S71~S64		
		F0	*		*		*		*		
8	00	S31~S24		S23~S16		S15~S08		S07~S00		COM32	
	10	S63~S56		S55~S48		S47~S40		S39~S32			
	20	*		*		S79~S72		S71~S64			
	30	*		*		*		*			
		40	S31~S24		S23~S16		S15~S08		S07~S00		COM33
		50	S63~S56		S55~S48		S47~S40		S39~S32		
		60	*		*		S79~S72		S71~S64		
		70	*		*		*		*		
		80	S31~S24		S23~S16		S15~S08		S07~S00		COM34
		90	S63~S56		S55~S48		S47~S40		S39~S32		
		A0	*		*		S79~S72		S71~S64		
		B0	*		*		*		*		
		C0	S31~S24		S23~S16		S15~S08		S07~S00		COM35
		D0	S63~S56		S55~S48		S47~S40		S39~S32		
		E0	*		*		S79~S72		S71~S64		
		F0	*		*		*		*		
9	00	S31~S24		S23~S16		S15~S08		S07~S00		COM36	
	10	S63~S56		S55~S48		S47~S40		S39~S32			
	20	*		*		S79~S72		S71~S64			
	30	*		*		*		*			
		40	S31~S24		S23~S16		S15~S08		S07~S00		COM37
		50	S63~S56		S55~S48		S47~S40		S39~S32		
		60	*		*		S79~S72		S71~S64		
		70	*		*		*		*		
		80	S31~S24		S23~S16		S15~S08		S07~S00		COM38
		90	S63~S56		S55~S48		S47~S40		S39~S32		
		A0	*		*		S79~S72		S71~S64		
		B0	*		*		*		*		
		C0	S31~S24		S23~S16		S15~S08		S07~S00		COM39
		D0	S63~S56		S55~S48		S47~S40		S39~S32		
		E0	*		*		S79~S72		S71~S64		
		F0	*		*		*		*		
A	00	S31~S24		S23~S16		S15~S08		S07~S00		COM40	
	10	S63~S56		S55~S48		S47~S40		S39~S32			
	20	*		*		S79~S72		S71~S64			
	30	*		*		*		*			
	40	S31~S24		S23~S16		S15~S08		S07~S00			



16 Gray Levels LCD Display RAM MAP												
Page		F	C	B	8	7	4	3	0	COM No.		
	50	S63~S56	S55~S48	S47~S40	S39~S32							
	60	*	*	S79~S72	S71~S64							
	70	*	*	*	*							
		80	S31~S24	S23~S16	S15~S08	S07~S00					COM42	
		90	S63~S56	S55~S48	S47~S40	S39~S32						
		A0	*	*	S79~S72	S71~S64						
		B0	*	*	*	*						
		C0	S31~S24	S23~S16	S15~S08	S07~S00						
		D0	S63~S56	S55~S48	S47~S40	S39~S32						
		E0	*	*	S79~S72	S71~S64					COM43	
F0		*	*	*	*							
B		00	S31~S24	S23~S16	S15~S08	S07~S00						COM44
		10	S63~S56	S55~S48	S47~S40	S39~S32						
	20	*	*	S79~S72	S71~S64							
	30	*	*	*	*							
	40	S31~S24	S23~S16	S15~S08	S07~S00					COM45		
	50	S63~S56	S55~S48	S47~S40	S39~S32							
	60	*	*	S79~S72	S71~S64							
	70	*	*	*	*							
	80	S31~S24	S23~S16	S15~S08	S07~S00							
	90	S63~S56	S55~S48	S47~S40	S39~S32							
	A0	*	*	S79~S72	S71~S64					COM46		
	B0	*	*	*	*							
	C0	S31~S24	S23~S16	S15~S08	S07~S00							
	D0	S63~S56	S55~S48	S47~S40	S39~S32							
	E0	*	*	S79~S72	S71~S64							
	F0	*	*	*	*							
C	00	S31~S24	S23~S16	S15~S08	S07~S00					COM48		
	10	S63~S56	S55~S48	S47~S40	S39~S32							
	20	*	*	S79~S72	S71~S64							
	30	*	*	*	*							
		40	S31~S24	S23~S16	S15~S08	S07~S00					COM49	
		50	S63~S56	S55~S48	S47~S40	S39~S32						
		60	*	*	S79~S72	S71~S64						
		70	*	*	*	*						
		80	S31~S24	S23~S16	S15~S08	S07~S00						
		90	S63~S56	S55~S48	S47~S40	S39~S32						
		A0	*	*	S79~S72	S71~S64					COM50	
		B0	*	*	*	*						
		C0	S31~S24	S23~S16	S15~S08	S07~S00						
		D0	S63~S56	S55~S48	S47~S40	S39~S32						
E0		*	*	S79~S72	S71~S64							
F0		*	*	*	*							
D	00	S31~S24	S23~S16	S15~S08	S07~S00					COM51		
	10	S63~S56	S55~S48	S47~S40	S39~S32							
	20	*	*	S79~S72	S71~S64							
	30	*	*	*	*							
	40	S31~S24	S23~S16	S15~S08	S07~S00					COM52		
	50	S63~S56	S55~S48	S47~S40	S39~S32							
	60	*	*	S79~S72	S71~S64							
	70	*	*	*	*							



16 Gray Levels LCD Display RAM MAP										
Page		F	C	B	8	7	4	3	0	COM No.
	40	S31~S24	S23~S16	S15~S08	S07~S00	COM53				
	50	S63~S56	S55~S48	S47~S40	S39~S32					
	60	*	*	S79~S72	S71~S64					
	70	*	*	*	*					
	COM54	80	S31~S24	S23~S16	S15~S08	S07~S00				
		90	S63~S56	S55~S48	S47~S40	S39~S32				
		A0	*	*	S79~S72	S71~S64				
		B0	*	*	*	*				
	COM55	C0	S31~S24	S23~S16	S15~S08	S07~S00				
		D0	S63~S56	S55~S48	S47~S40	S39~S32				
		E0	*	*	S79~S72	S71~S64				
		F0	*	*	*	*				
E	00	S31~S24	S23~S16	S15~S08	S07~S00	COM56				
	10	S63~S56	S55~S48	S47~S40	S39~S32					
	20	*	*	S79~S72	S71~S64					
	30	*	*	*	*					
	COM57	40	S31~S24	S23~S16	S15~S08	S07~S00				
		50	S63~S56	S55~S48	S47~S40	S39~S32				
		60	*	*	S79~S72	S71~S64				
		70	*	*	*	*				
	COM58	80	S31~S24	S23~S16	S15~S08	S07~S00				
		90	S63~S56	S55~S48	S47~S40	S39~S32				
		A0	*	*	S79~S72	S71~S64				
		B0	*	*	*	*				
	COM59	C0	S31~S24	S23~S16	S15~S08	S07~S00				
		D0	S63~S56	S55~S48	S47~S40	S39~S32				
		E0	*	*	S79~S72	S71~S64				
		F0	*	*	*	*				
F	00	S31~S24	S23~S16	S15~S08	S07~S00	COM60				
	10	S63~S56	S55~S48	S47~S40	S39~S32					
	20	*	*	S79~S72	S71~S64					
	30	*	*	*	*					
	COM61	40	S31~S24	S23~S16	S15~S08	S07~S00				
		50	S63~S56	S55~S48	S47~S40	S39~S32				
		60	*	*	S79~S72	S71~S64				
		70	*	*	*	*				
	COM62	80	S31~S24	S23~S16	S15~S08	S07~S00				
		90	S63~S56	S55~S48	S47~S40	S39~S32				
		A0	*	*	S79~S72	S71~S64				
		B0	*	*	*	*				
	COM63	C0	S31~S24	S23~S16	S15~S08	S07~S00				
		D0	S63~S56	S55~S48	S47~S40	S39~S32				
		E0	*	*	S79~S72	S71~S64				
		F0	*	*	*	*				
10	00	S31~S24	S23~S16	S15~S08	S07~S00	COM64				
	10	S63~S56	S55~S48	S47~S40	S39~S32					
	20	*	*	S79~S72	S71~S64					



16 Gray Levels LCD Display RAM MAP										
Page		F	C	B	8	7	4	3	0	COM No.
	30	*		*		*		*		
	40	S31~S24		S23~S16		S15~S08		S07~S00		COM65
	50	S63~S56		S55~S48		S47~S40		S39~S32		
	60	*		*		S79~S72		S71~S64		
	70	*		*		*		*		
	80	S31~S24		S23~S16		S15~S08		S07~S00		
	COM66	90	S63~S56		S55~S48		S47~S40		S39~S32	
		A0	*		*		S79~S72		S71~S64	
		B0	*		*		*		*	
		C0	S31~S24		S23~S16		S15~S08		S07~S00	
	COM67	D0	S63~S56		S55~S48		S47~S40		S39~S32	
		E0	*		*		S79~S72		S71~S64	
F0		*		*		*		*		
11	00	S31~S24		S23~S16		S15~S08		S07~S00		COM68
	10	S63~S56		S55~S48		S47~S40		S39~S32		
	20	*		*		S79~S72		S71~S64		
	30	*		*		*		*		
	COM69	40	S31~S24		S23~S16		S15~S08		S07~S00	
		50	S63~S56		S55~S48		S47~S40		S39~S32	
		60	*		*		S79~S72		S71~S64	
		70	*		*		*		*	
	COM70	80	S31~S24		S23~S16		S15~S08		S07~S00	
		90	S63~S56		S55~S48		S47~S40		S39~S32	
		A0	*		*		S79~S72		S71~S64	
		B0	*		*		*		*	
	COM71	C0	S31~S24		S23~S16		S15~S08		S07~S00	
		D0	S63~S56		S55~S48		S47~S40		S39~S32	
		E0	*		*		S79~S72		S71~S64	
		F0	*		*		*		*	
12	00	S31~S24		S23~S16		S15~S08		S07~S00		COM72
	10	S63~S56		S55~S48		S47~S40		S39~S32		
	20	*		*		S79~S72		S71~S64		
	30	*		*		*		*		
	COM73	40	S31~S24		S23~S16		S15~S08		S07~S00	
		50	S63~S56		S55~S48		S47~S40		S39~S32	
		60	*		*		S79~S72		S71~S64	
		70	*		*		*		*	
	COM74	80	S31~S24		S23~S16		S15~S08		S07~S00	
		90	S63~S56		S55~S48		S47~S40		S39~S32	
		A0	*		*		S79~S72		S71~S64	
		B0	*		*		*		*	
	COM75	C0	S31~S24		S23~S16		S15~S08		S07~S00	
		D0	S63~S56		S55~S48		S47~S40		S39~S32	
		E0	*		*		S79~S72		S71~S64	
		F0	*		*		*		*	
13	00	S31~S24		S23~S16		S15~S08		S07~S00		COM76
	10	S63~S56		S55~S48		S47~S40		S39~S32		



16 Gray Levels LCD Display RAM MAP										
Page		F	C	B	8	7	4	3	0	COM No.
0	20	*		*		S79~S72		S71~S64		COM77
	30	*		*		*		*		
	40	S31~S24		S23~S16		S15~S08		S07~S00		
	50	S63~S56		S55~S48		S47~S40		S39~S32		
	60	*		*		S79~S72		S71~S64		
	70	*		*		*		*		
	80	S31~S24		S23~S16		S15~S08		S07~S00		COM78
	90	S63~S56		S55~S48		S47~S40		S39~S32		
	A0	*		*		S79~S72		S71~S64		
	B0	*		*		*		*		
	C0	S31~S24		S23~S16		S15~S08		S07~S00		COM79
	D0	S63~S56		S55~S48		S47~S40		S39~S32		
	E0	*		*		S79~S72		S71~S64		
	F0	*		*		*		*		

6.2. 4 Gray Scale LCD Display RAM Map

4 Gray Levels LCD Display RAM MAP										
Page		F	C	B	8	7	4	3	0	COM No.
0	00	S63~S48		S47~S32		S32~S16		S15~S00		COM0
	10	*		*		*		S79~S64		
	20	S63~S48		S47~S32		S32~S16		S15~S00		COM1
	30	*		*		*		S79~S64		
	40	S63~S48		S47~S32		S32~S16		S15~S00		COM2
	50	*		*		*		S79~S64		
	60	S63~S48		S47~S32		S32~S16		S15~S00		COM3
	70	*		*		*		S79~S64		
	80	S63~S48		S47~S32		S32~S16		S15~S00		COM4
	90	*		*		*		S79~S64		
	A0	S63~S48		S47~S32		S32~S16		S15~S00		COM5
	B0	*		*		*		S79~S64		
	C0	S63~S48		S47~S32		S32~S16		S15~S00		COM6
	D0	*		*		*		S79~S64		
E0	S63~S48		S47~S32		S32~S16		S15~S00		COM7	
F0	*		*		*		S79~S64			
1	00	S63~S48		S47~S32		S32~S16		S15~S00		COM8
	10	*		*		*		S79~S64		
	20	S63~S48		S47~S32		S32~S16		S15~S00		COM9
	30	*		*		*		S79~S64		
	40	S63~S48		S47~S32		S32~S16		S15~S00		COM10
	50	*		*		*		S79~S64		
	60	S63~S48		S47~S32		S32~S16		S15~S00		COM11
	70	*		*		*		S79~S64		



4 Gray Levels LCD Display RAM MAP										
Page		F	C	B	8	7	4	3	0	COM No.
	80	S63~S48	S47~S32	S32~S16	S15~S00	COM12				
	90	*	*	*	S79~S64					
	A0	S63~S48	S47~S32	S32~S16	S15~S00	COM13				
	B0	*	*	*	S79~S64					
	C0	S63~S48	S47~S32	S32~S16	S15~S00	COM14				
	D0	*	*	*	S79~S64					
	E0	S63~S48	S47~S32	S32~S16	S15~S00	COM15				
	F0	*	*	*	S79~S64					
2	00	S63~S48	S47~S32	S32~S16	S15~S00	COM16				
	10	*	*	*	S79~S64					
	20	S63~S48	S47~S32	S32~S16	S15~S00	COM17				
	30	*	*	*	S79~S64					
	40	S63~S48	S47~S32	S32~S16	S15~S00	COM18				
	50	*	*	*	S79~S64					
	60	S63~S48	S47~S32	S32~S16	S15~S00	COM19				
	70	*	*	*	S79~S64					
	80	S63~S48	S47~S32	S32~S16	S15~S00	COM20				
	90	*	*	*	S79~S64					
	A0	S63~S48	S47~S32	S32~S16	S15~S00	COM21				
	B0	*	*	*	S79~S64					
	C0	S63~S48	S47~S32	S32~S16	S15~S00	COM22				
	D0	*	*	*	S79~S64					
	E0	S63~S48	S47~S32	S32~S16	S15~S00	COM23				
	F0	*	*	*	S79~S64					
3	00	S63~S48	S47~S32	S32~S16	S15~S00	COM24				
	10	*	*	*	S79~S64					
	20	S63~S48	S47~S32	S32~S16	S15~S00	COM25				
	30	*	*	*	S79~S64					
	40	S63~S48	S47~S32	S32~S16	S15~S00	COM26				
	50	*	*	*	S79~S64					
	60	S63~S48	S47~S32	S32~S16	S15~S00	COM27				
	70	*	*	*	S79~S64					
	80	S63~S48	S47~S32	S32~S16	S15~S00	COM28				
	90	*	*	*	S79~S64					
	A0	S63~S48	S47~S32	S32~S16	S15~S00	COM29				
	B0	*	*	*	S79~S64					
	C0	S63~S48	S47~S32	S32~S16	S15~S00	COM30				
	D0	*	*	*	S79~S64					
	E0	S63~S48	S47~S32	S32~S16	S15~S00	COM31				
	F0	*	*	*	S79~S64					
4	00	S63~S48	S47~S32	S32~S16	S15~S00	COM32				
	10	*	*	*	S79~S64					
	20	S63~S48	S47~S32	S32~S16	S15~S00	COM33				
	30	*	*	*	S79~S64					
	40	S63~S48	S47~S32	S32~S16	S15~S00	COM34				
	50	*	*	*	S79~S64					
	60	S63~S48	S47~S32	S32~S16	S15~S00	COM35				



4 Gray Levels LCD Display RAM MAP										
Page		F	C	B	8	7	4	3	0	COM No.
	70	*		*		*		S79~S64		
	80	S63~S48		S47~S32		S32~S16		S15~S00		COM36
	90	*		*		*		S79~S64		
	A0	S63~S48		S47~S32		S32~S16		S15~S00		COM37
	B0	*		*		*		S79~S64		
	C0	S63~S48		S47~S32		S32~S16		S15~S00		COM38
	D0	*		*		*		S79~S64		
	E0	S63~S48		S47~S32		S32~S16		S15~S00		COM39
5	F0	*		*		*		S79~S64		
	00	S63~S48		S47~S32		S32~S16		S15~S00		COM40
	10	*		*		*		S79~S64		
	20	S63~S48		S47~S32		S32~S16		S15~S00		COM41
	30	*		*		*		S79~S64		
	40	S63~S48		S47~S32		S32~S16		S15~S00		COM42
	50	*		*		*		S79~S64		
	60	S63~S48		S47~S32		S32~S16		S15~S00		COM43
	70	*		*		*		S79~S64		
	80	S63~S48		S47~S32		S32~S16		S15~S00		COM44
	90	*		*		*		S79~S64		
	A0	S63~S48		S47~S32		S32~S16		S15~S00		COM45
	B0	*		*		*		S79~S64		
	C0	S63~S48		S47~S32		S32~S16		S15~S00		COM46
	D0	*		*		*		S79~S64		
	E0	S63~S48		S47~S32		S32~S16		S15~S00		COM47
6	F0	*		*		*		S79~S64		
	00	S63~S48		S47~S32		S32~S16		S15~S00		COM48
	10	*		*		*		S79~S64		
	20	S63~S48		S47~S32		S32~S16		S15~S00		COM49
	30	*		*		*		S79~S64		
	40	S63~S48		S47~S32		S32~S16		S15~S00		COM50
	50	*		*		*		S79~S64		
	60	S63~S48		S47~S32		S32~S16		S15~S00		COM51
	70	*		*		*		S79~S64		
	80	S63~S48		S47~S32		S32~S16		S15~S00		COM52
	90	*		*		*		S79~S64		
	A0	S63~S48		S47~S32		S32~S16		S15~S00		COM53
	B0	*		*		*		S79~S64		
	C0	S63~S48		S47~S32		S32~S16		S15~S00		COM54
	D0	*		*		*		S79~S64		
	E0	S63~S48		S47~S32		S32~S16		S15~S00		COM55
7	F0	*		*		*		S79~S64		
	00	S63~S48		S47~S32		S32~S16		S15~S00		COM56
	10	*		*		*		S79~S64		
	20	S63~S48		S47~S32		S32~S16		S15~S00		COM57
	30	*		*		*		S79~S64		
	40	S63~S48		S47~S32		S32~S16		S15~S00		COM58
50	*		*		*		S79~S64			



4 Gray Levels LCD Display RAM MAP										
Page		F	C	B	8	7	4	3	0	COM No.
	60	S63~S48	S47~S32	S32~S16	S15~S00	COM59				
	70	*	*	*	S79~S64					
	80	S63~S48	S47~S32	S32~S16	S15~S00	COM60				
	90	*	*	*	S79~S64					
	A0	S63~S48	S47~S32	S32~S16	S15~S00	COM61				
	B0	*	*	*	S79~S64					
	C0	S63~S48	S47~S32	S32~S16	S15~S00	COM62				
	D0	*	*	*	S79~S64					
	E0	S63~S48	S47~S32	S32~S16	S15~S00	COM63				
	F0	*	*	*	S79~S64					
8	00	S63~S48	S47~S32	S32~S16	S15~S00	COM64				
	10	*	*	*	S79~S64					
	20	S63~S48	S47~S32	S32~S16	S15~S00	COM65				
	30	*	*	*	S79~S64					
	40	S63~S48	S47~S32	S32~S16	S15~S00	COM66				
	50	*	*	*	S79~S64					
	60	S63~S48	S47~S32	S32~S16	S15~S00	COM67				
	70	*	*	*	S79~S64					
	80	S63~S48	S47~S32	S32~S16	S15~S00	COM68				
	90	*	*	*	S79~S64					
	A0	S63~S48	S47~S32	S32~S16	S15~S00	COM69				
	B0	*	*	*	S79~S64					
	C0	S63~S48	S47~S32	S32~S16	S15~S00	COM70				
	D0	*	*	*	S79~S64					
E0	S63~S48	S47~S32	S32~S16	S15~S00	COM71					
F0	*	*	*	S79~S64						
9	00	S63~S48	S47~S32	S32~S16	S15~S00	COM72				
	10	*	*	*	S79~S64					
	20	S63~S48	S47~S32	S32~S16	S15~S00	COM73				
	30	*	*	*	S79~S64					
	40	S63~S48	S47~S32	S32~S16	S15~S00	COM74				
	50	*	*	*	S79~S64					
	60	S63~S48	S47~S32	S32~S16	S15~S00	COM75				
	70	*	*	*	S79~S64					
	80	S63~S48	S47~S32	S32~S16	S15~S00	COM76				
	90	*	*	*	S79~S64					
	A0	S63~S48	S47~S32	S32~S16	S15~S00	COM77				
	B0	*	*	*	S79~S64					
	C0	S63~S48	S47~S32	S32~S16	S15~S00	COM78				
	D0	*	*	*	S79~S64					
E0	S63~S48	S47~S32	S32~S16	S15~S00	COM79					
F0	*	*	*	S79~S64						

6.3. Black and White LCD Display RAM Map

2 Gray Levels (Black/White) LCD Display RAM MAP										
Page		F	A	9	8	7	4	3	0	COM No.
0	00	*		S79~S64	S63~S32	S31~S00				COM0
	10	*		S79~S64	S63~S32	S31~S00				COM1
	20	*		S79~S64	S63~S32	S31~S00				COM2
	30	*		S79~S64	S63~S32	S31~S00				COM3
	40	*		S79~S64	S63~S32	S31~S00				COM4
	50	*		S79~S64	S63~S32	S31~S00				COM5
	60	*		S79~S64	S63~S32	S31~S00				COM6
	70	*		S79~S64	S63~S32	S31~S00				COM7
	80	*		S79~S64	S63~S32	S31~S00				COM8
	90	*		S79~S64	S63~S32	S31~S00				COM9
	A0	*		S79~S64	S63~S32	S31~S00				COM10
	B0	*		S79~S64	S63~S32	S31~S00				COM11
	C0	*		S79~S64	S63~S32	S31~S00				COM12
	D0	*		S79~S64	S63~S32	S31~S00				COM13
	E0	*		S79~S64	S63~S32	S31~S00				COM14
	F0	*		S79~S64	S63~S32	S31~S00				COM15
1	00	*		S79~S64	S63~S32	S31~S00				COM16
	10	*		S79~S64	S63~S32	S31~S00				COM17
	20	*		S79~S64	S63~S32	S31~S00				COM18
	30	*		S79~S64	S63~S32	S31~S00				COM19
	40	*		S79~S64	S63~S32	S31~S00				COM20
	50	*		S79~S64	S63~S32	S31~S00				COM21
	60	*		S79~S64	S63~S32	S31~S00				COM22
	70	*		S79~S64	S63~S32	S31~S00				COM23
	80	*		S79~S64	S63~S32	S31~S00				COM24
	90	*		S79~S64	S63~S32	S31~S00				COM25
	A0	*		S79~S64	S63~S32	S31~S00				COM26
	B0	*		S79~S64	S63~S32	S31~S00				COM27
	C0	*		S79~S64	S63~S32	S31~S00				COM28
	D0	*		S79~S64	S63~S32	S31~S00				COM29
	E0	*		S79~S64	S63~S32	S31~S00				COM30
	F0	*		S79~S64	S63~S32	S31~S00				COM31
2	00	*		S79~S64	S63~S32	S31~S00				COM32
	10	*		S79~S64	S63~S32	S31~S00				COM33
	20	*		S79~S64	S63~S32	S31~S00				COM34
	30	*		S79~S64	S63~S32	S31~S00				COM35
	40	*		S79~S64	S63~S32	S31~S00				COM36
	50	*		S79~S64	S63~S32	S31~S00				COM37
	60	*		S79~S64	S63~S32	S31~S00				COM38
	70	*		S79~S64	S63~S32	S31~S00				COM39
	80	*		S79~S64	S63~S32	S31~S00				COM40
	90	*		S79~S64	S63~S32	S31~S00				COM41
A0	*		S79~S64	S63~S32	S31~S00				COM42	



2 Gray Levels (Black/White) LCD Display RAM MAP										
Page		F	A	9	8	7	4	3	0	COM No.
	B0	*		S79~S64	S63~S32	S31~S00				COM43
	C0	*		S79~S64	S63~S32	S31~S00				COM44
	D0	*		S79~S64	S63~S32	S31~S00				COM45
	E0	*		S79~S64	S63~S32	S31~S00				COM46
	F0	*		S79~S64	S63~S32	S31~S00				COM47
3	00	*		S79~S64	S63~S32	S31~S00				COM48
	10	*		S79~S64	S63~S32	S31~S00				COM49
	20	*		S79~S64	S63~S32	S31~S00				COM50
	30	*		S79~S64	S63~S32	S31~S00				COM51
	40	*		S79~S64	S63~S32	S31~S00				COM52
	50	*		S79~S64	S63~S32	S31~S00				COM53
	60	*		S79~S64	S63~S32	S31~S00				COM54
	70	*		S79~S64	S63~S32	S31~S00				COM55
	80	*		S79~S64	S63~S32	S31~S00				COM56
	90	*		S79~S64	S63~S32	S31~S00				COM57
	A0	*		S79~S64	S63~S32	S31~S00				COM58
	B0	*		S79~S64	S63~S32	S31~S00				COM59
	C0	*		S79~S64	S63~S32	S31~S00				COM60
	D0	*		S79~S64	S63~S32	S31~S00				COM61
	E0	*		S79~S64	S63~S32	S31~S00				COM62
F0	*		S79~S64	S63~S32	S31~S00				COM63	
4	00	*		S79~S64	S63~S32	S31~S00				COM64
	10	*		S79~S64	S63~S32	S31~S00				COM65
	20	*		S79~S64	S63~S32	S31~S00				COM66
	30	*		S79~S64	S63~S32	S31~S00				COM67
	40	*		S79~S64	S63~S32	S31~S00				COM68
	50	*		S79~S64	S63~S32	S31~S00				COM69
	60	*		S79~S64	S63~S32	S31~S00				COM70
	70	*		S79~S64	S63~S32	S31~S00				COM71
	80	*		S79~S64	S63~S32	S31~S00				COM72
	90	*		S79~S64	S63~S32	S31~S00				COM73
	A0	*		S79~S64	S63~S32	S31~S00				COM74
	B0	*		S79~S64	S63~S32	S31~S00				COM75
	C0	*		S79~S64	S63~S32	S31~S00				COM76
	D0	*		S79~S64	S63~S32	S31~S00				COM77
	E0	*		S79~S64	S63~S32	S31~S00				COM78
F0	*		S79~S64	S63~S32	S31~S00				COM79	

7. Command Interface

KB's MCU with Segment Extender Interface controls KD83 by an 8-bit parallel data/command bus. The D_CN and R_WN pins select current activity to be a Command read/write or Data Read/Write. The STBN signal is the active low strobe signal to read/write to the command registers or read/write RAM content. There are 19 command registers which can be read/write in cyclic order. The command sequence



are reset by any read/write to data or power-on reset or REN=1 or RES_N=0. The COM counter are reset to 00H by LEP=0 or LFR signal transient.

cmd seq	Bit7	Bit6	Bit5	Bit4	Bit3	Bit2	Bit1	Bit0	Reset
1	A7	A6	A5	A4	A3	A2	A1	A0	0000 0000
2	LEP	WR_INC	RD_INC	A12	A11	A10	A9	A8	0010 0000
3	KS	COMS2	COMS1	COMS0	GRAY_MODE		-	-	1011 11--
4	X			GRAY0					---0 0000
5				GRAY1					---0 0010
6				GRAY2					---0 0100
7				GRAY3					---0 0110
8				GRAY4					---0 1000
9				GRAY5					---0 1010
10				GRAY6					---0 1100
11				GRAY7					---0 1110
12				GRAY8					---1 0000
13				GRAY9					---1 0010
14				GRAYA					---1 0100
15				GRAYB					---1 0110
16				GRAYC					---1 1000
17				GRAYD					---1 1010
18	GRAYE					---1 1100			
19	GRAYF					---1 1110			

The address of display RAM can be configured to increment with each Read or Write access by setting the WR_INC and RD_INC bit of CMD2 register.

A12~A0: display RAM address

RD_INC: address auto increment when read

WR_INC: address auto increment when write

WR_INC	RD_INC	A [12..0]
0	0	Automatically increment by one with each data read/write access
0	1	Automatically increment by one with each data write access
1	0	Automatically increment by one with each data read access
1	1	No automatically increment by one

LEP: LCD enable, 0: Disable 1: Enable

COMS[2..0]: LCD Configuration

COMS[2]	COMS[1]	COMS[0]	LCD configuration
1	0	0	16 COM (COM15 ~COM0)
0	0	0	32 COM (COM31 ~COM0)
0	0	1	48 COM (COM47 ~COM0)
0	1	0	64 COM (COM63 ~COM0)
0	1	1	80 COM (COM79 ~COM0)

GRAY_MODE:

GRAY MODE		Gray Scales
0	0	16
0	1	4
1	0	Black and White

KS: Key Board Scan 0: Disable 1: Enable

8. Timing Diagram

1. reset

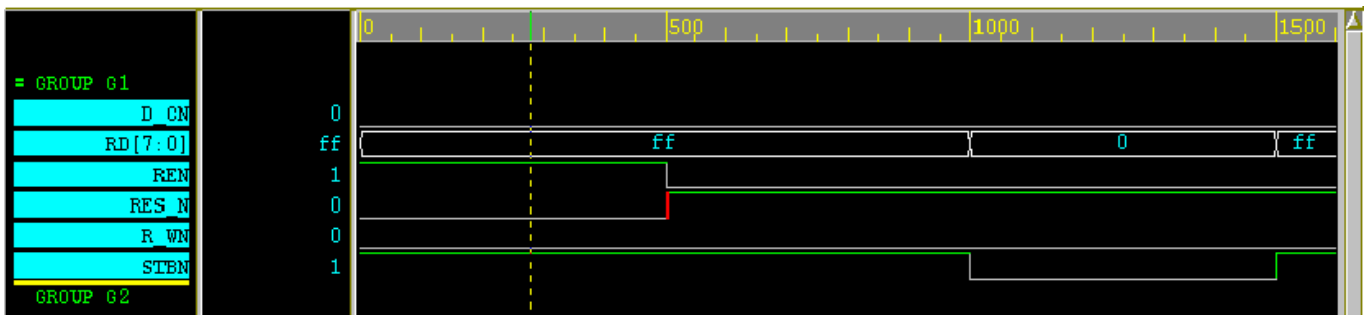

2. command_write

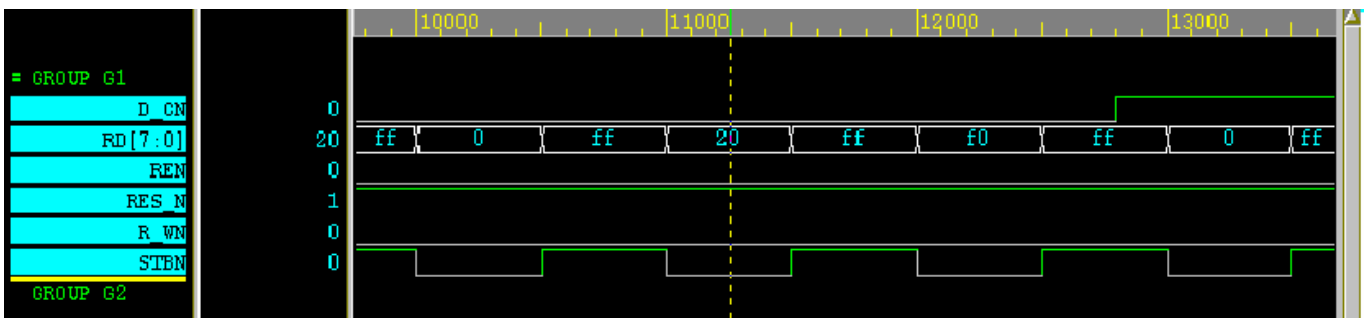

3. data write

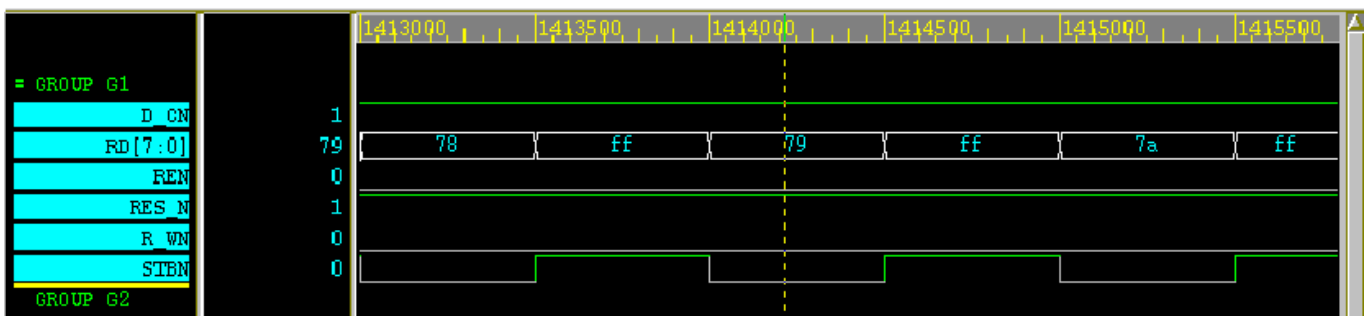

4. command read

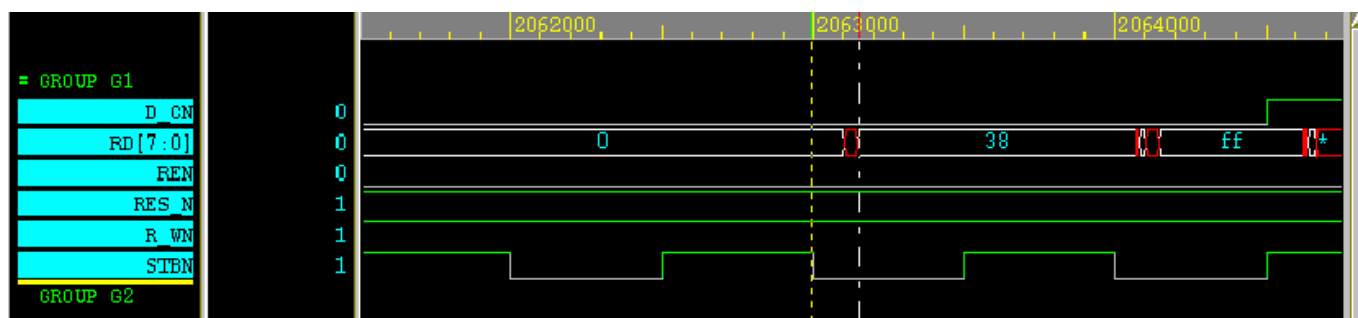

5. data read

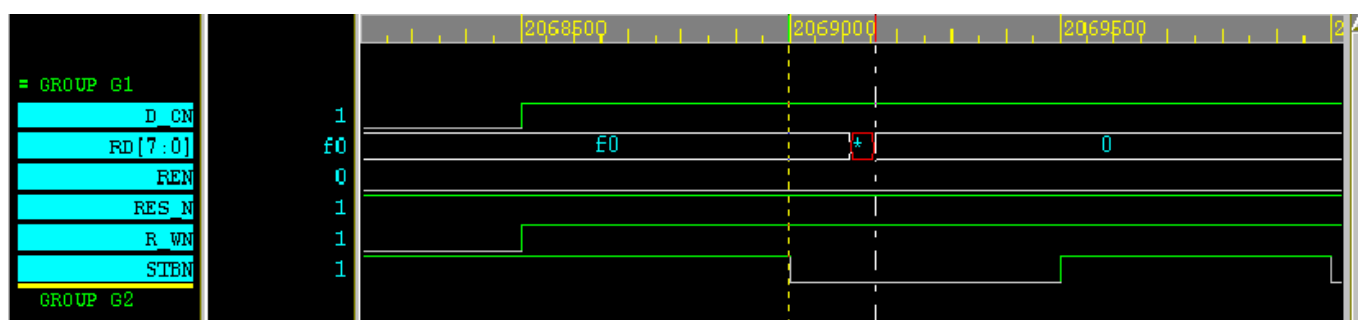

9. Absolute Maximum Rating

Item	Sym.	Rating	Condition
Supply Voltage	V_{DD}	-0.5V ~ 4V	
Input Voltage	V_{IN}	-0.5V ~ $V_{dd}+0.5V$	
Output Voltage	V_o	-0.5V ~ $V_{dd}+0.5V$	
Operating Temperature	T_{OP}	0°C ~ 70°C	
Storage Temperature	T_{ST}	-50°C ~ 100°C	

10. Recommended Operating Conditions

Item	Sym.	Rating	Condition
Supply Voltage	V_{DD}	2.4V ~ 3.6V	
LCD Operating Voltage	V_{LVP}	<12V	
Input Voltage	V_{IH}	0.9 V_{DD} ~ V_{DD}	
	V_{IL}	0.0V ~ 0.1 V_{dd}	
Operating Temperature	T_{op}	0°C ~ 70°C	
Storage Temperature	T_{ST}	-50°C ~ 100°C	

11. AC/DC Characteristics

Parameters	Symbol	Min.	Typ.	Max.	Unit	Condition
Supply Current	I_{DD}		200	220	μA	
Standby mode current	I_{Sstdby}			1	μA	



Parameters	Symbol	Min.	Typ.	Max.	Unit	Condition
Input high voltage	V_{IH}	0.8			V_{DD}	Input pins
Input low voltage	V_{IL}			0.2	V_{DD}	Input pins
Input leakage current	I_{IL}		20		μA	$V_{IL} = GND, V_{DD}$
Input Hysteresis Width	V_{HYS}		1/3		V_{DD}	Input pins Threshold= $2/3V_{DD}$ (input from low to high) Threshold= $1/3V_{DD}$ (input from high to low)
Output source current	I_{OH}	-2.0			mA	RD[7..0], $V_{OL}=2.0V$
Output sink current	I_{OL}			2.0	mA	RD[7..0], $V_{OL}=0.4V$

12. Application Circuit

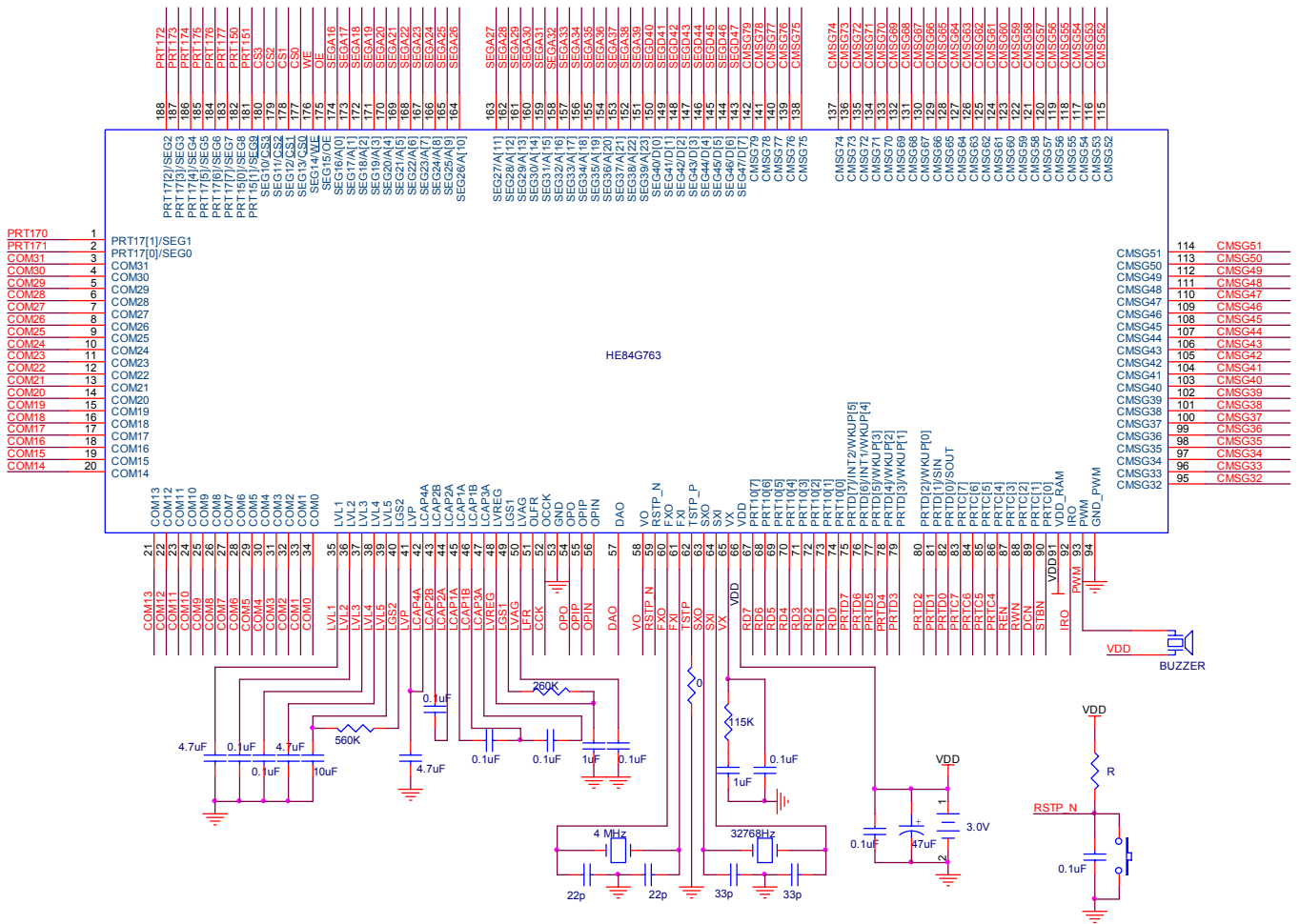

This application assumes 48COM X 80SEG configuration, and 80 SEG Extender KDG80.

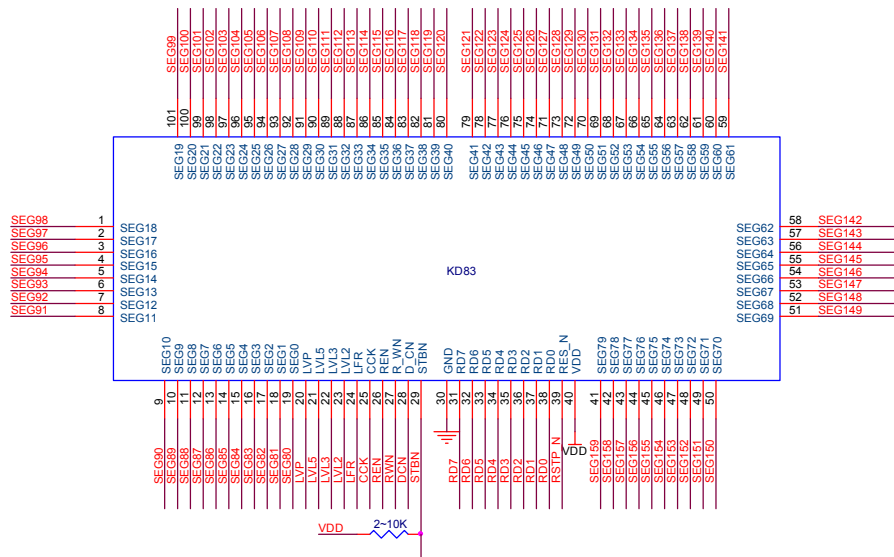



Note: Options for LCD, Osc. and external memory

COMXSEG	32X96	48X80	64X64	80X48
CM5G32	SEG95	COM32	COM32	COM32
CM5G33	SEG94	COM33	COM33	COM33
CM5G34	SEG93	COM34	COM34	COM34
CM5G35	SEG92	COM35	COM35	COM35
CM5G36	SEG91	COM36	COM36	COM36
CM5G37	SEG90	COM37	COM37	COM37
CM5G38	SEG89	COM38	COM38	COM38
CM5G39	SEG88	COM39	COM39	COM39
CM5G40	SEG87	COM40	COM40	COM40
CM5G41	SEG86	COM41	COM41	COM41
CM5G42	SEG85	COM42	COM42	COM42
CM5G43	SEG84	COM43	COM43	COM43
CM5G44	SEG83	COM44	COM44	COM44
CM5G45	SEG82	COM45	COM45	COM45
CM5G46	SEG81	COM46	COM46	COM46
CM5G47	SEG80	COM47	COM47	COM47
CM5G48	SEG79	COM48	COM48	COM48
CM5G49	SEG78	COM49	COM49	COM49
CM5G50	SEG77	COM50	COM50	COM50
CM5G51	SEG76	COM51	COM51	COM51
CM5G52	SEG75	COM52	COM52	COM52
CM5G53	SEG74	COM53	COM53	COM53
CM5G54	SEG73	COM54	COM54	COM54
CM5G55	SEG72	COM55	COM55	COM55
CM5G56	SEG71	COM56	COM56	COM56
CM5G57	SEG70	COM57	COM57	COM57
CM5G58	SEG69	COM58	COM58	COM58
CM5G59	SEG68	COM59	COM59	COM59
CM5G60	SEG67	COM60	COM60	COM60
CM5G61	SEG66	COM61	COM61	COM61
CM5G62	SEG65	COM62	COM62	COM62
CM5G63	SEG64	COM63	COM63	COM63
CM5G64	SEG63	COM64	COM64	COM64
CM5G65	SEG62	COM65	COM65	COM65
CM5G66	SEG61	COM66	COM66	COM66
CM5G67	SEG60	COM67	COM67	COM67
CM5G68	SEG59	COM68	COM68	COM68
CM5G69	SEG58	COM69	COM69	COM69
CM5G70	SEG57	COM70	COM70	COM70
CM5G71	SEG56	COM71	COM71	COM71
CM5G72	SEG55	COM72	COM72	COM72
CM5G73	SEG54	COM73	COM73	COM73
CM5G74	SEG53	COM74	COM74	COM74
CM5G75	SEG52	COM75	COM75	COM75
CM5G76	SEG51	COM76	COM76	COM76
CM5G77	SEG50	COM77	COM77	COM77
CM5G78	SEG49	COM78	COM78	COM78
CM5G79	SEG48	COM79	COM79	COM79

Ext. Bus Interface

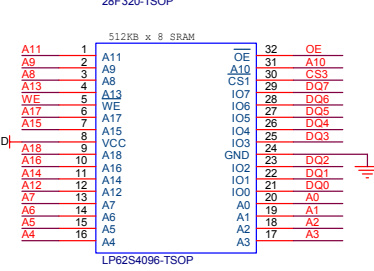
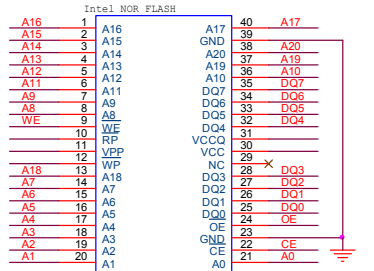
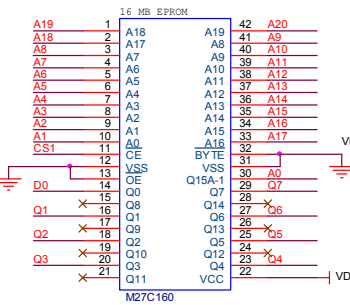
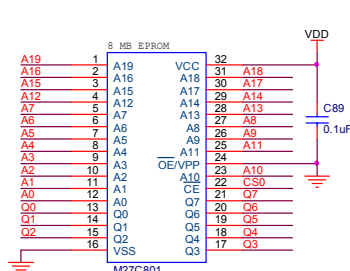
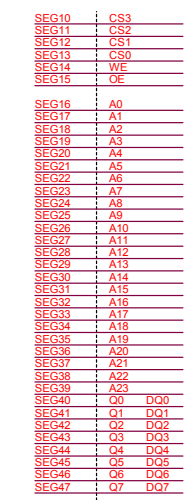

OE	SEG15	OE
WE	SEG14	WE
CS0	SEG13	CS0
CS1	SEG12	CS1
CS2	SEG11	CS2
CS3	SEG10	CS3
PRT151	SEG9	PRT151
PRT150	SEG8	PRT150
PRT177	SEG7	PRT177
PRT176	SEG6	PRT176
PRT175	SEG5	PRT175
PRT174	SEG4	PRT174
PRT173	SEG3	PRT173
PRT172	SEG2	PRT172
PRT171	SEG1	PRT171
PRT170	SEG0	PRT170

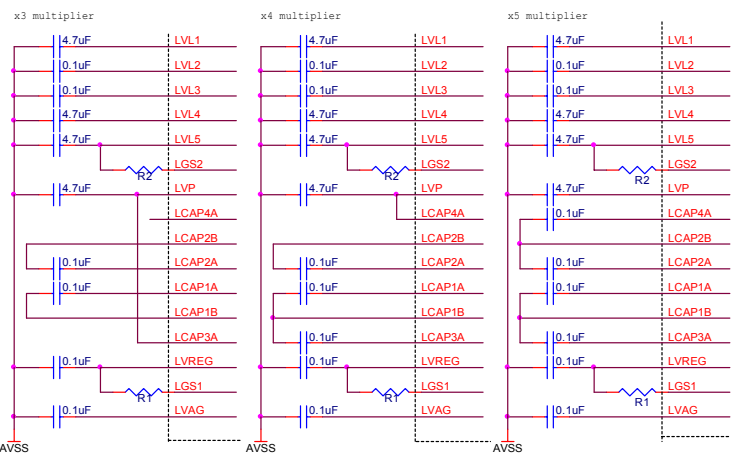
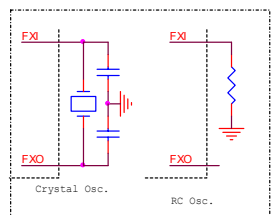
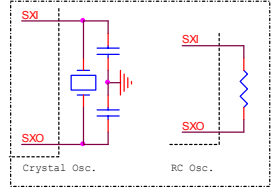



13. Updated History

Version	Date	Update Record
V1.0	10/30/03	New release version