



TSM106

Dual Operational Amplifier and Voltage Reference

Operational Amplifier:

- Low input offset voltage: 1mV typ.
- Medium bandwidth (unity gain): 0.9MHz
- Large output voltage swing: 0V to ($V_{CC} - 1.5V$)
- Input common mode voltage range includes ground
- Wide power supply range: 4 to 32V ± 2 TO $\pm 16V$
- 1.5kV ESD protection (HBM)

Voltage Reference:

- Fixed output voltage reference 0.83V
- $\pm 1\%$ Voltage precision

DESCRIPTION

The TSM106 is a monolithic IC that includes one independent op-amp and another op-amp for which the non-inverting input is wired to a 0.83V fixed voltage reference. This device offers both space and cost savings in many applications such as power supply management or data acquisition systems.

ORDER CODES

Part Number	Temperature Range	Package	Packaging	Marking
TSM106ID	-40°C, +105°C	SO	Tube	M106
TSM106IDT		SO	Tape & Reel	

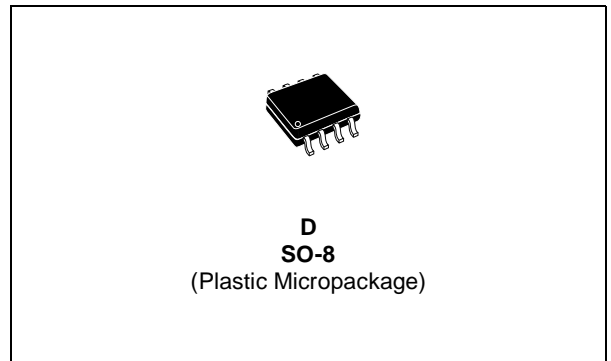

PIN CONNECTIONS (top view)

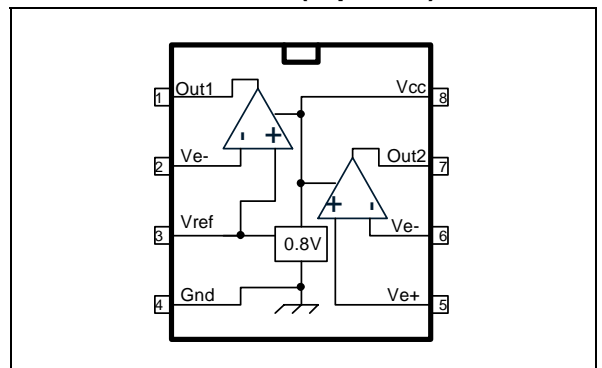

1 Absolute Maximum Ratings

Table 1: Key parameters and their absolute maximum ratings

Symbol	Parameter	Value	Unit
V_{CC}	Supply Voltage	36	V
V_{id}	Differential Input Voltage	36	V
V_i	Input Voltage	-0.3 to $V_{CC} + 0.3V$	V
T_{oper}	Operating Free-air Temperature Range	-40 to +105	°C
T_j	Maximum Junction Temperature	150	°C
R_{thja}	Thermal Resistance Junction to Ambient (SO package)	175	°C/W
T_l	Maximum Lead Temperature (10 seconds maximum)	260	°C
ESD	Electrostatic Discharge Protection	1.5	kV

2 Electrical Characteristics

Table 2: General electrical characteristics

Symbol	Parameter	Min.	Typ.	Max.	Unit
I_{CC}	Total Supply Current $V_{CC+} = 5V$, no load $T_{min.} < T_{amb} < T_{max.}$		2.5	4.5	mA
	$V_{CC+} = 30V$, no load $T_{min.} < T_{amb} < T_{max.}$		5.5	8.5 10	

Table 3: Electrical characteristics for operator 2 (independent op-amp): $V_{CC+} = +5V$, $V_{CC} =$ Ground, $V_o = 1.4V$, $T_{amb} = 25^{\circ}C$ (unless otherwise specified)

Symbol	Parameter	Min.	Typ.	Max.	Unit
V_{io}	Input Offset Voltage $V_{icm} = 0V$ $T_{amb} = 25^{\circ}$ $T_{min.} \leq T_{amb} \leq T_{max.}$		1	4 5	mV
	DV_{io}	Input Offset Voltage Drift		7	
I_{io}	Input Offset Current $T_{min.} \leq T_{amb} \leq T_{max.}$		2	75 150	nA
I_{ib}	Input Bias Current $T_{min.} \leq T_{amb} \leq T_{max.}$		20	150 200	nA
A_{vd}	Large Signal Voltage Gain $V_{CC} = 15V$, $R_L = 2k$, $V_o = 1.4V$ to $11.4V$ $T_{min.} \leq T_{amb} \leq T_{max.}$	50 25	100		V/mV
SVR	Supply Voltage Rejection Ratio $V_{CC} = 5V$ to $30V$	65	100		dB
V_{icm}	Input Common Mode Voltage Range $V_{CC} = +30V$ - see note ¹ $T_{min.} \leq T_{amb} \leq T_{max.}$	0 0		$(V_{CC+}) - 1.5$ $(V_{CC+}) - 2$	V
CMR	Common Mode Rejection Ratio $T_{min.} \leq T_{amb} \leq T_{max.}$	70 60	85		dB
I_{source}	Output Current Source $V_{CC} = +15V$, $V_o = 2V$, $V_{id} = +1V$	20	40		mA
I_o	Short Circuit to Ground $V_{CC} = +15V$		40	60	mA

Table 3: Electrical characteristics for operator 2 (independent op-amp): VCC+ = +5V, VCC = Ground, Vo = 1.4V, Tamb = 25°C (unless otherwise specified)

Symbol	Parameter	Min.	Typ.	Max.	Unit
I_{sink}	Output Current Sink $V_{\text{id}} = -1\text{V}$, $V_{\text{CC}} = +15\text{V}$, $V_{\text{o}} = 2\text{V}$	10	20		mA
V_{OH}	High Level Output Voltage $T_{\text{min.}} \leq T_{\text{amb}} \leq T_{\text{max}}$ $T_{\text{amb}} = 25^\circ\text{C}$, $R_{\text{L}} = 10\text{k}$ $T_{\text{min.}} \leq T_{\text{amb}} \leq T_{\text{max.}}$	27 27	28		V
V_{OL}	Low Level Output Voltage $R_{\text{L}} = 10\text{k}$ $T_{\text{min.}} \leq T_{\text{amb}} \leq T_{\text{max.}}$		5	20 20	mV
SR	Slew Rate at Unity Gain $V_{\text{i}} = 0.5$ to 3V , $V_{\text{CC}} = 15\text{V}$ $R_{\text{L}} = 2\text{k}$, $C_{\text{L}} = 100\text{pF}$, unity gain	0.2	0.4		V/ μs
GBP	Gain Bandwidth Product $V_{\text{CC}} = 30\text{V}$, $R_{\text{L}} = 2\text{k}$, $C_{\text{L}} = 100\text{pF}$ $f = 100\text{kHz}$, $V_{\text{in}} = 10\text{mV}$	0.5	0.9		MHz
THD	Total Harmonic Distortion $f = 1\text{kHz}$ $A_{\text{V}} = 20\text{dB}$, $R_{\text{L}} = 2\text{k}$, $V_{\text{CC}} = 30\text{V}$ $C_{\text{L}} = 100\text{pF}$, $V_{\text{o}} = 2V_{\text{pp}}$		0.02		%
e_{n}	Equivalent Input Noise Voltage $f = 1\text{kHz}$, $R_{\text{s}} = 100\Omega$ $V_{\text{CC}} = 30\text{V}$		50		nV/ $\sqrt{\text{Hz}}$

1) The input common-mode voltage of either input signal voltage should not be allowed to go negative by more than 0.3V. The upper end of the common-mode voltage range is $V_{\text{CC}}^+ - 1.5\text{V}$. Both inputs can go to $V_{\text{CC}} + 0.3\text{V}$ without damage.

Table 4: Electrical characteristics for operator 1 (op-amp with non-inverting input connected to the internal Vref): VCC+ = +5V, VCC- = Ground, Tamb = 25°C (unless otherwise specified)

Symbol	Parameter	Min.	Typ.	Max.	Unit
V_{io}	Input Offset Voltage $V_{\text{icm}} = 0.83\text{V}$ $V_{\text{CC}} = 5\text{V}$ or 30V $T_{\text{amb}} = 25^\circ$ $T_{\text{min.}} \leq T_{\text{amb}} \leq T_{\text{max.}}$		1	4 5	mV
DV_{io}	Input Offset Voltage Drift		7		$\mu\text{V}/^\circ\text{C}$
I_{ib}	Input Bias Current negative input		20		nA
SVR	Supply Voltage Rejection Ratio $V_{\text{icm}} = 0.83\text{V}$ $V_{\text{CC}}^+ = 5\text{V}$ to 30V	65	100		dB
I_{source}	Output Current Source $V_{\text{o}} = 2\text{V}$ $V_{\text{CC}} = +15\text{V}$, $V_{\text{id}} = +1\text{V}$	20	40		mA
I_{o}	Short Circuit to Ground $V_{\text{CC}} = +15\text{V}$		40	60	mA
I_{sink}	Output Current Sink $V_{\text{id}} = -1\text{V}$, $V_{\text{CC}} = +15\text{V}$, $V_{\text{o}} = 2\text{V}$	10	20		mA

Table 4: Electrical characteristics for operator 1 (op-amp with non-inverting input connected to the internal Vref): VCC+ = +5V, VCC- = Ground, Tamb = 25°C (unless otherwise specified)

Symbol	Parameter	Min.	Typ.	Max.	Unit
V_{OH}	High Level Output Voltage $V_{CC+} = 30V$ $T_{amb} = 25^{\circ}C, R_L = 10k$ $T_{min.} \leq T_{amb} \leq T_{max.}$	27 27	28		V
V_{OL}	Low Level Output Voltage $R_L = 10k$ $T_{min.} \leq T_{amb} \leq T_{max.}$		5	20 20	mV
THD	Total Harmonic Distortion $f = 1kHz$ $A_V = 20dB, R_L = 2k, V_{CC} = 30V$ $C_L = 100pF, V_o = 2V_{pp}$		0.02		%

Table 5: Electrical characteristics for voltage reference

Symbol	Parameter	Min.	Typ.	Max.	Unit
V_{ref}	Reference Input Voltage $T_{amb} = 25^{\circ}C$ $T_{min.} \leq T_{amb} \leq T_{max.}$	0.822	0.83V	0.838	V
Regline	Reference Input Voltage over Vcc range $V_{icm} = 3.7V \text{ to } 30V, T_{amb} = 25^{\circ}C$ $T_{min.} \leq T_{amb} \leq T_{max.}$		3	6 10	mV
Regload	Reference Input Voltage over Ioutref current $I_{outref} = 1mA \text{ to } 10mA, T_{amb} = 25^{\circ}C$ $T_{min.} \leq T_{amb} \leq T_{max.}$		10	20 25	mV
ΔV_{ref}	Reference Input Voltage Deviation Over Temperature Range $T_{min.} \leq T_{amb} \leq T_{max.}$		7	30	mV

3 Package Mechanical Data

SO-8 MECHANICAL DATA

DIM.	mm.			inch		
	MIN.	TYP	MAX.	MIN.	TYP.	MAX.
A	1.35		1.75	0.053		0.069
A1	0.10		0.25	0.04		0.010
A2	1.10		1.65	0.043		0.065
B	0.33		0.51	0.013		0.020
C	0.19		0.25	0.007		0.010
D	4.80		5.00	0.189		0.197
E	3.80		4.00	0.150		0.157
e		1.27			0.050	
H	5.80		6.20	0.228		0.244
h	0.25		0.50	0.010		0.020
L	0.40		1.27	0.016		0.050
k	8° (max.)					
ddd			0.1			0.04

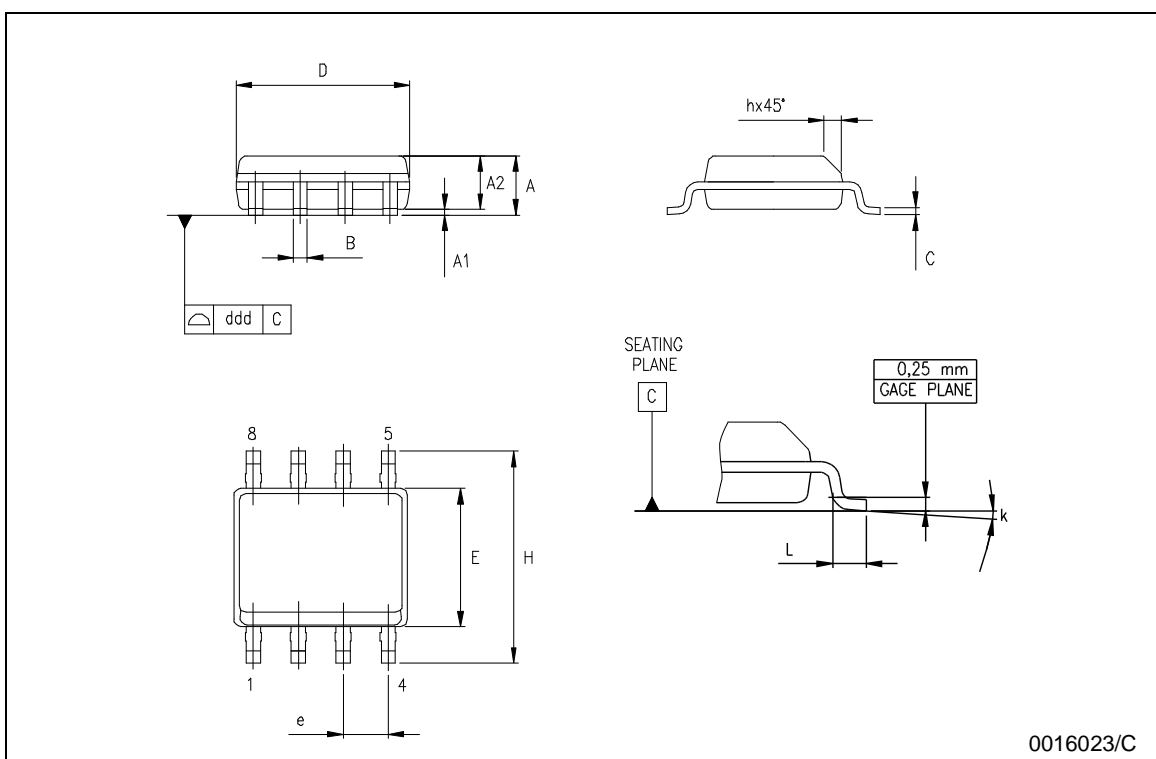

0016023/C

4 Revision History

Date	Revision	Description of Changes
July 2004	1	First Release
September 2004	2	Modifications on first page: $V_{io} = 1\text{mV}$ Curves will be added in the future

Information furnished is believed to be accurate and reliable. However, STMicroelectronics assumes no responsibility for the consequences of use of such information nor for any infringement of patents or other rights of third parties which may result from its use. No license is granted by implication or otherwise under any patent or patent rights of STMicroelectronics. Specifications mentioned in this publication are subject to change without notice. This publication supersedes and replaces all information previously supplied. STMicroelectronics products are not authorized for use as critical components in life support devices or systems without express written approval of STMicroelectronics.

The ST logo is a registered trademark of STMicroelectronics
All other names are the property of their respective owners

© 2004 STMicroelectronics - All rights reserved

STMicroelectronics group of companies

Australia - Belgium - Brazil - Canada - China - Czech Republic - Finland - France - Germany - Hong Kong - India - Israel - Italy - Japan - Malaysia - Malta - Morocco - Singapore - Spain - Sweden - Switzerland - United Kingdom - United States of America

www.st.com