



TSCD144C

Dual NPN Digital Transistor

SOT-363



Pin assignment:

1. TR1 Gnd (Emitter)
2. TR1 Input (Base)
3. TR2 Output (Collector)
4. TR2 Gnd (Emitter)
5. TR2 Input (Base)
6. TR1 Output (Collector)

V_{cc} = 50V
V_{in} = - 10V ~ +12V
I_o = 100mA(max.)

Features

- ◇ Build-in bias resistor enable the configuration of an inverter circuit without connecting external input resistors (see equivalent circuit)
- ◇ The bias resistors consist of thin-film resistors with complete isolation to allow negative biasing of the input. The also have the advantage of almost completely eliminating parasitic effects.
- ◇ Only the on/off conditions need to be set for operation, making device design easy.
- ◇ Two TSC144C chips in a SOT-363 package
- ◇ Transistor elements are independent, eliminating interference
- ◇ Complements the TSAD144C

Equivalent Circuit

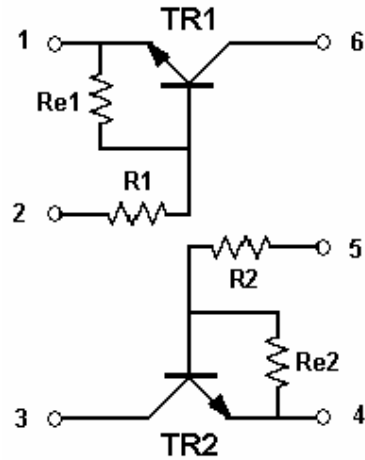

R1=47kohm, R2=47kohm
Re1=47kohm, Re2=47kohm

Ordering Information

Part No.	Packing	Package
TSCD144CCU6	Tape & Reel	SOT-363

Note: the build-in resistor value type, option as

No.	Re (KΩ)	R (KΩ)	Marking
TR 1	47	47	7C
TR 2	47	47	

Absolute Maximum Rating (Ta = 25 °C unless otherwise noted)

Parameter	Symbol	Limit	Unit
Supply Voltage	V _{cc}	50	V
Input Voltage	V _{in}	- 10 ~ +12	V
Output Current	I _o	100	mA
		100	
Power Dissipation (note)	P _D	200	mW
Operating Junction Temperature	T _J	+150	°C
Operating Junction and Storage Temperature Range	T _{STG}	- 55 to +150	°C

- Note: 1. Single pulse, P_w = 300uS, Duty <= 2%
 2. 150mW per element must not be exceeded.



Electrical Characteristics						
Ta = 25 °C unless otherwise noted						
Parameter	Conditions	Symbol	Min	Typ	Max	Unit
Input Voltage	Vcc= 5V, Io= 100uA	Vin(off)	--	--	0.5	V
	Vo= 0.3V, Io= 2mA	Vin(on)	3	--	--	V
Output Voltage	Io/Iin= 10mA/ 0.5mA	Vo(on)	--	0.1	0.3	V
Input Current	Vin= 5V	Iin	--	--	0.18	mA
Output Current	Vcc= 50V, Vin= 0V	Io(off)	--	--	0.5	uA
DC Current Gain	Vo= 5V, Io= 5mA	Gi	68	--	--	
Input Resistance		R1	0.7	47	1.3	KΩ
Resistance Ratio		R2/R1	0.8	1	1.2	
Transition Frequency	Vce= 10V, Ie= 5mA, f= 100MHz (note 1)	ft	--	250	--	MHz

Note : 1. Transition frequency of the device.

2. Pulse test: pulse width $\leq 380\mu\text{s}$, duty cycle $\leq 2\%$

Electrical Characteristics Curve

current gain vs output current

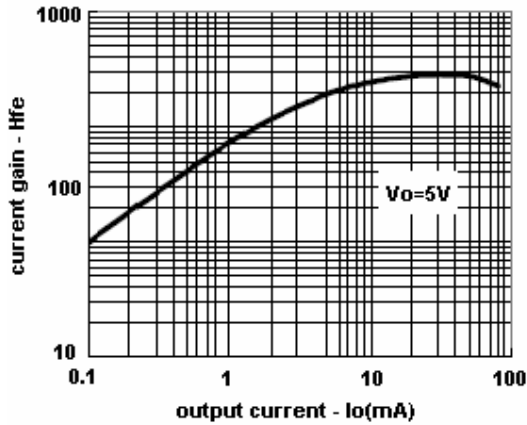

output voltage vs output current

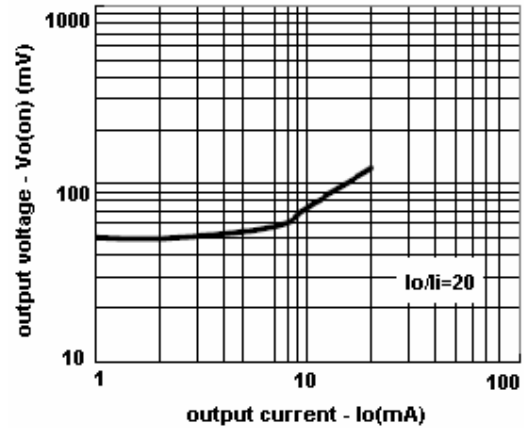

input voltage vs output current (on)

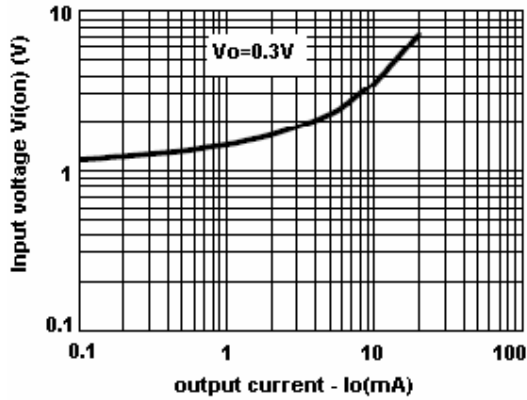

output current vs input voltage (off)

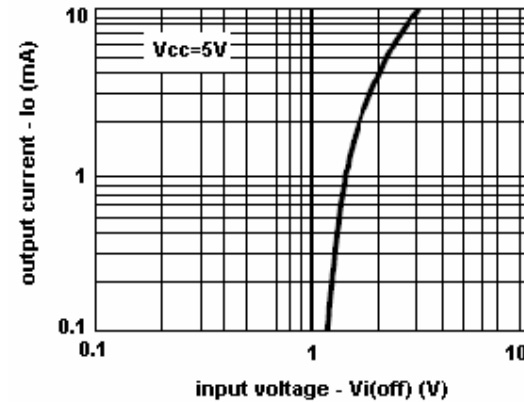

power dissipation vs temperature

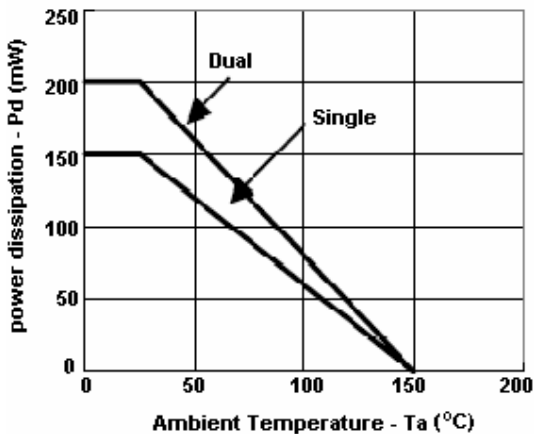

SOT-363 Mechanical Drawing

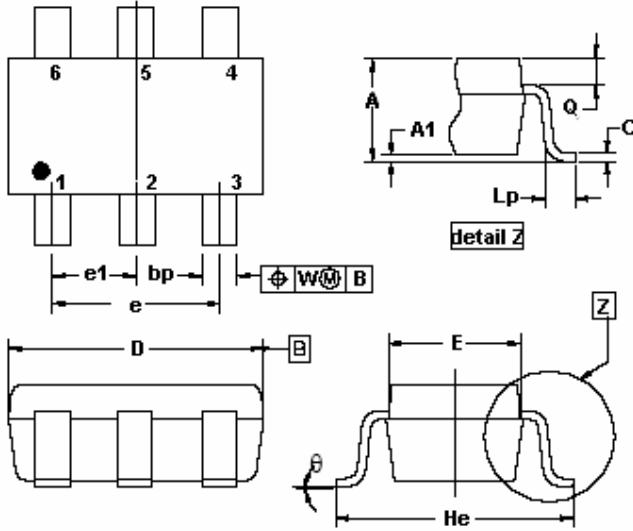

SOT-363 DIMENSION				
DIM	MILLIMETERS		INCHES	
	MIN	MAX	MIN	MAX
A	0.80	1.10	0.031	0.043
A1	--	0.10	--	0.004
bp	0.10	0.30	0.004	0.012
C	0.10	0.25	0.004	0.010
D	1.80	2.20	0.071	0.087
E	1.15	1.35	0.045	0.053
e	1.30 (typ)		0.052 (typ)	
e1	0.65 (typ)		0.026 (typ)	
He	2.00	2.20	0.079	0.087
Lp	0.10	0.3	0.004	0.012
Q	0.20 (typ)		0.008 (typ)	
W	0.20 (typ)		0.008 (typ)	
θ	10° (typ)		10° (typ)	