

TPC Series Tri-direction Scan Switch

Features/Benefits

- One touch, 3 way switching
- Superior tactile feel
- Rotation of actuator closes two individual contacts
- Ultra-low profile housing
- Normally open contacts
- Custom actuator by request
- RoHS compliant and compatible

Typical Applications

- Mobile phones, pagers
- PDA
- Handheld electronic devices
- Digital cameras, camcorders
- Communication equipment



TPC 1133G



TPC 2133G

Construction

FUNCTION: Multi-directional momentary action
CONTACT ARRANGEMENT: Make contact = SP, N.O.
TERMINALS: Gullwing type for SMT

Mechanical

MAXIMUM ACTUATION FORCE: 20 N (select), 10 N (left & right).
OPERATING FORCE/TRAVEL:

Direction	Actuation Force	Travel
Left	1.0 ± 0.5 N	16° ± 4°
Right	1.0 ± 0.5 N	16° ± 4°
Select	2.2 ± 0.75 N	0.8 mm ± 0.2 (0.030 ± 0.006)

Operating life = 150 K cumulated operations (50 K ops in both scanning directions then 50 K ops in select direction)

Packaging

Switches are delivered in tape and reels of 2,000 pieces. The reel diameter is 330 mm (12.99). The tape width 24 mm (0.945) conforms to the EIA-RS-481 and EC-2863 norms.

Electrical

MAXIMUM POWER: 1.0 VA
MAXIMUM VOLTAGE: 32 V
MAXIMUM CURRENT DC: 50 mA
MINIMUM CURRENT DC: 1 mA
LOW LEVEL USE: 20mV-1mA
DIELECTRIC STRENGTH: 250 Vrms
CONTACT RESISTANCE: ≤ 300 mΩ (select) ≤ 1Ω (left & right)
INSULATION RESISTANCE (100 VDC): 10⁹ Ω
BOUNCE TIME: < 10 ms

Environmental

OPERATING TEMPERATURE: -40°C to 125°C
STORAGE TEMPERATURE: -55°C to 125°C

Process

Soldering process: Compatible with the lead free soldering process.

Note: Specifications listed above are for switches with standard options.
For information concerning design integration, please contact your local ITT representative.

How To Order

Our easy build-a-switch concept allows you to mix and match options to create the switch you need. To order, select desired option from each category and place it in the appropriate box.

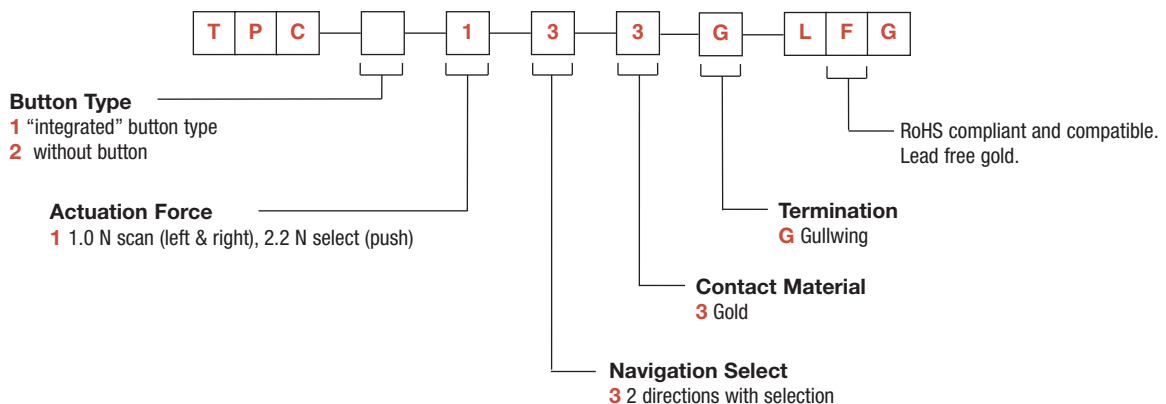

TPC Series Tri-direction Scan Switch

TPC 1133G

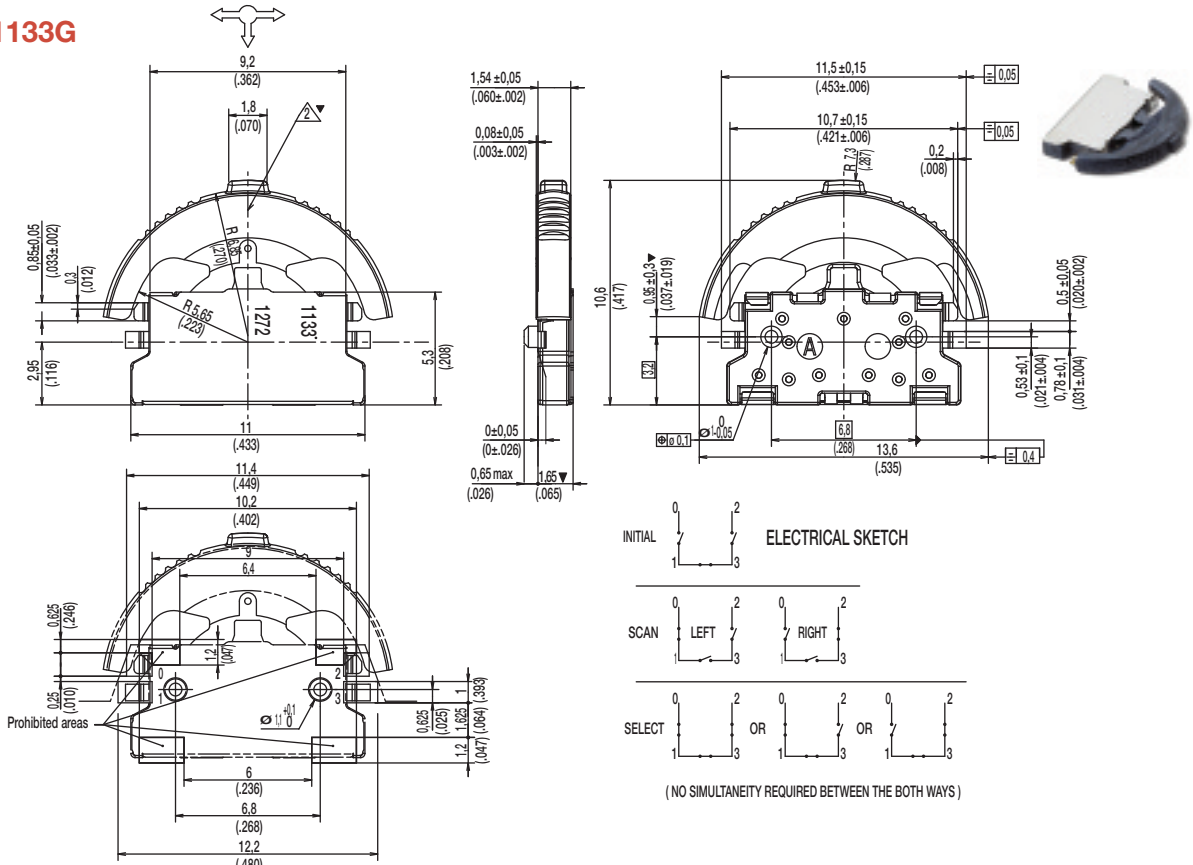

Date Code appears on TPC
First Line: product identification number
Second Line: year, week number and day

TAPE & REEL

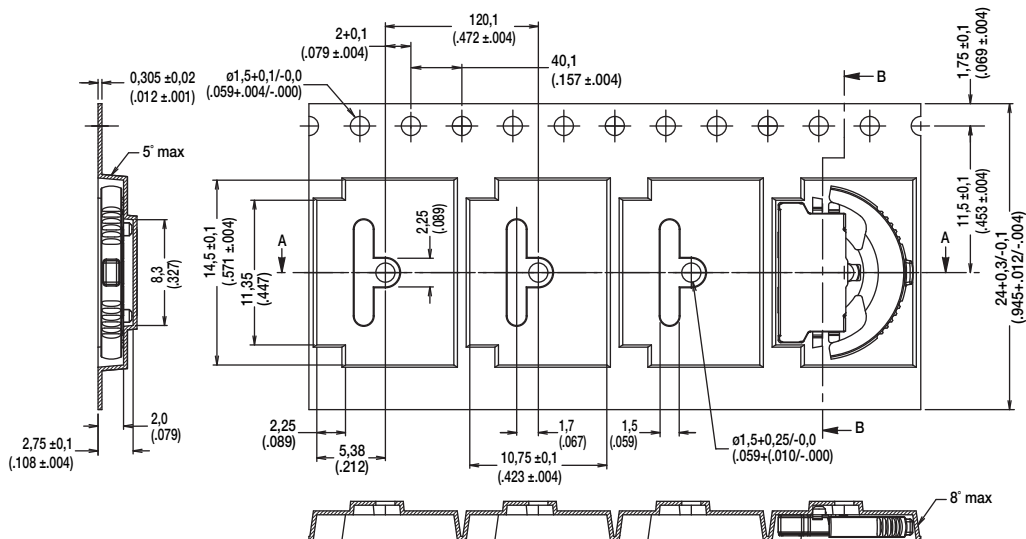

Dimensions are shown: mm (inch)
Specifications and dimensions subject to change

www.ittcannon.com



TPC Series Tri-direction Scan Switch

TPC2133G

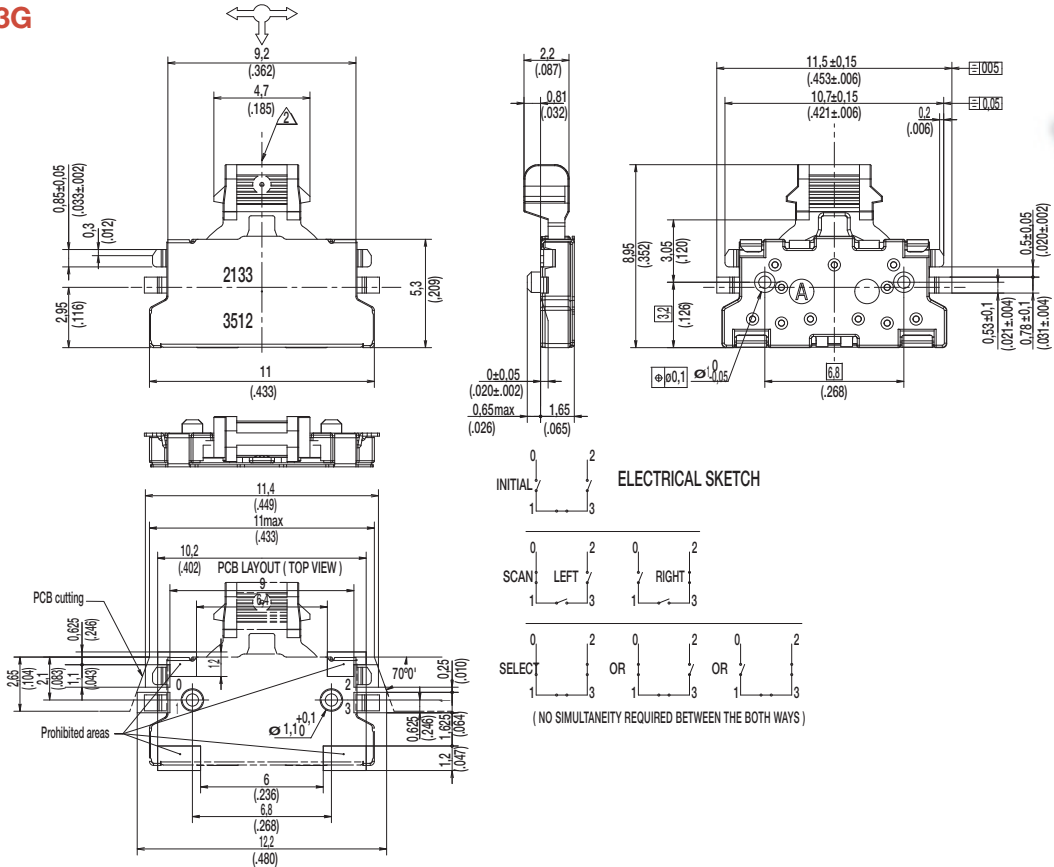

Date Code appears on TPC
 First Line: product identification number
 Second Line: year, week number and day

TAPE & REEL

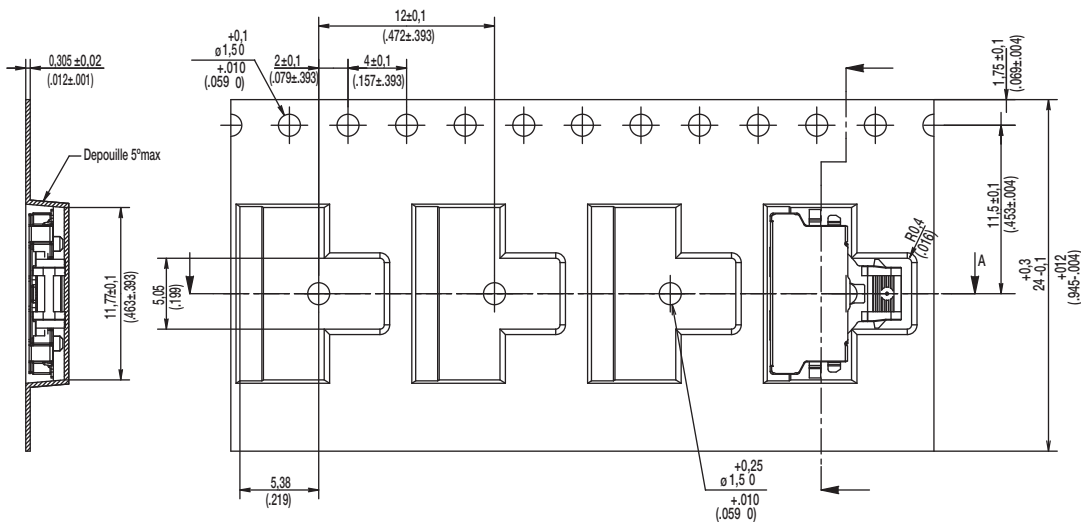

Dimensions are shown: mm (inch)
 Specifications and dimensions subject to change

