

# T63H0001A

# Li-Ion Battery Protector

## Features

<b>Low supply current</b>	<b>Supply current</b>	<b>TYP. 5.0uA</b>
	<b>Standby current (after detecting over-discharge)</b>	<b>TYP. 0.3uA</b>
<b>High withstand voltage</b>	<b>Absolute maximum ratings</b>	<b>20V(VDD-VM)</b>
<b>High accuracy detector</b>	<b>Over-charge detector</b>	<b>+/- 25mV</b>
<b>Threshold</b>	<b>Over-discharge detector</b>	<b>+/- 2.5%</b>
<b>Variety of detector threshold</b>	<b>Over-charge detector threshold</b>	<b>4.0V to 4.4V</b>
	<b>Over-discharge detector threshold</b>	<b>2.4V to 3.0V</b>
<b>Built in protection circuit</b>	<b>Excess current trip/Short circuit protector</b>	
<b>Output delay of over charge</b>	<b>Time delay at C3=0.01uF &amp; VDD=4.3V</b>	<b>170Ms<sup>note1</sup></b>

note1: The result was measured from T63H0001A-AX.

## Part Number Examples

Part No.	Over charge detection voltage	Over charge release voltage	marking	Pack type
T63H0001A-AX	4.25V	4.05V	001A	SOT-23-6
T63H0001A-BX	4.35V	4.15V	001B	SOT-23-6
T63H0001A-CX	4.30V	4.10V	001C	SOT-23-6
... <sup>*note1</sup>	....	....		....

note1: New model version and specific characteristics may be order by customer.

## General Description

The T63H0001A series are protection ICs for over-charge/discharge of rechargeable one-cell Lithium-ion (Li+) batteries by CMOS process. The T63H0001A series can detect over-charge/discharge of Li+ one-cell and excess load current, further include a short circuit protector for preventing large external short circuit current. Each of these ICs is composed of three voltage detectors, a reference unit, a hysteresis circuit, and a short circuit protector. When charging

voltage crosses the detector threshold from a low value to a value higher than Vdet1, the output of Cout pin, the output of over-charge detector/VD1, switches to low level. ... charger's negative pin level. After detecting over-charge the VD1 can be reset and the output of Cout pin becomes "H" when the VDD voltage is coming down to a level lower than "Vdet1-Vhys1", or when a charger is disconnected from the battery pack while the

VDD level is in between “Vdet1” and “Vdet1-Vhys1” in the T63H0001A version. The output of Dout pin, the output of over-discharge detector/VD2, switches to “Low” after internally fixed delay time passed, when discharging voltage crosses the detector threshold from a high value to a value lower than Vdet2. An excess load current can be sensed and cut off after internally fixed delay time passed through the built in excess current detector, VD3, with Dout being enabled to low level. Once after detecting excess current, the VD3 is released

and Dout level switches to “H” by detaching a battery pack from a load system. Further, short circuit protector makes Dout level to “L” immediately with external short circuit current and removing external short circuit leads Dout level to “H”. After detecting over-discharge, supply current will be kept extremely “L” by halting some internal circuits operation. The output delay of over-charge detectors can be set by connecting external capacitors. Output type of Cout and Dout are CMOS. SOT-23-6 is available.

**Block Diagram**

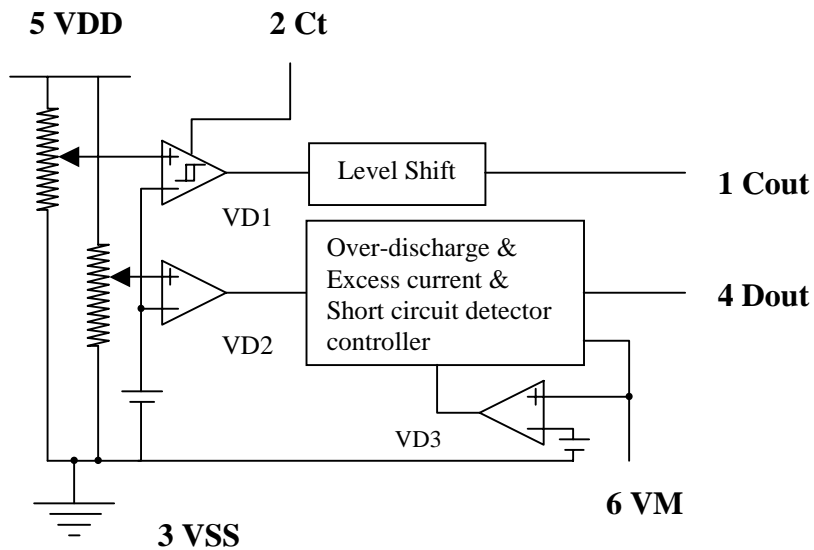

**Pin Configurations**

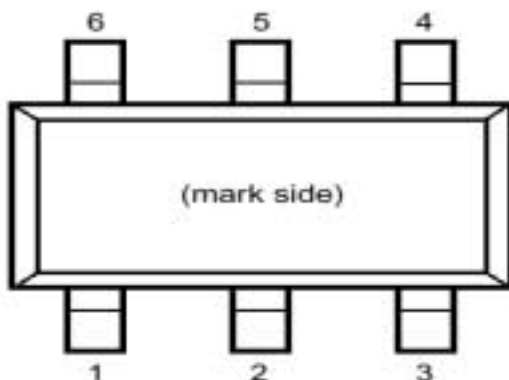

**Pin description**

Pin No.	Symbol	Pin description
1	Cout	Output of over-charge detection, CMOS output
2	Ct	Pin for external capacitor setting output delay of VD1
3	Vss	Ground
4	Dout	Output of over-discharge detection, CMOS output
5	Vdd	Power supply
6	VM	Pin for charger negative input

**ABSOLUTE MAXIMUM RATINGS**
*V<sub>ss</sub>=0V*

Symbol	Item	Rating	Unit	
Vdd	Supply Voltage	Vdd-VM	-0.3 to 20	V
VM	Input Voltage	VM pin	Vdd-20 to Vss+0.3	V
Vct		Ct pin	Vss-0.3 to Vss+0.3	V
Vcout	Output Voltage	Cout pin	Vdd-20 to Vss+0.3	V
Vdout		Dout pin	Vss-0.3 to Vss+0.3	V
Pd	Power Dissipation	150	mW	
Topt	Operating Temperature Range	-40 to +85	°C	
Tstg	Storage Temperature Range	-55 to +125	°C	

Absolute Maximum ratings are threshold limit values that must not be exceeded even for an instant under any conditions. Moreover, such values for any two items must not be reached simultaneously. Operation above these absolute maximum ratings may cause degradation or permanent damage to the device. These are stress ratings only and do not necessarily imply functional operation below these limits.

**Electrical Characteristic**

temp=25°C

Symbol	Item	Conditions	Min.	Typ.	Max.	Unit	
VDD1	Operating input voltage	Voltage defined as Vdd-VM	2.4		18	V	
Vdet1	Over-charge threshold voltage (Over charge detection voltage)	Detect rising edge of supply voltage	-AX	4.20	4.25	4.30	V
			-BX	4.30	4.35	4.40	V
			-CX	4.25	4.30	4.35	V
Voch	Over charge release voltage	-	-AX	4.00	4.05	4.10	V
			-BX	4.10	4.15	4.20	V
			-CX	4.05	4.10	4.15	V
Vhys1	Over-charge threshold hysteresis range	Vhys1=Vdet1-voch	0.15	0.20	0.25	V	
Tvdet1	Output delay time of over-charge	C3=0.01uF, Vdd=3.6V → 4.3V	140	170	210	ms	
Vdet2	Over-discharge threshold voltage	Detect falling edge of supply voltage	2.437	2.50	2.563	V	
Tvdet2	Output delay time of over-discharge	Vdd=3.6V → 2.4V	7	10	13	ms	
Vdet3	Excess current threshold voltage	Detect rising edge of VM pin voltage	0.1	0.12	0.14	V	
Tvdet3	Output delay time of excess current	Vdd=3V	9	13	17	ms	
Vshort	Short detection voltage	Vdd=3V	Vdd-1. 1	Vdd-0. 8	Vdd-0. 5	V	
Tshort	Output delay time of short current	Vdd=3V		5	50	us	
Rshort	Reset resistor for excess current protection	VDD=3.0V, VM=1.0V	50	100	150	Kohm	
Vol1	Nch ON voltage of Cout	Iol=50uA, Vdd=4.4V		0.2	0.5	V	
Voh1	Pch ON voltage of Cout	Ioh=-50uA, Vdd=3.9V	3.4	3.8		V	
Vol2	Nch ON voltage of Dout	Iol=50uA, Vdd=2.4V		0.2	0.5	V	
Voh2	Pch ON voltage of Dout	Ioh=-50uA, Vdd=3.9V	3.4	3.7		V	
Idd	Supply current	Vdd=3.9V, VM=0V		5.0	9.0	uA	
Istandby	Standby current	Vdd=2.0V		0.3	0.6	uA	

## Operation

### VD1/Over-Charge Detector

The VD1 monitors VDD pin voltage. When the VDD voltage crosses over-charge detector threshold Vdet1 from a low value to a value higher than the Vdelt1, the VD1 can sense over-charging and an external charge control Nch-MOS-FET turns to “OFF” with Cout pin

being at “L”.

An output delay time for over-charge detection can be set by an external capacitor C3 connecting the VSS pin and Ct pin. The external capacitor can make a delay time from a moment detecting over-charge to a time output a signal

which enables charge control Nch-MOS-FET for turning to “OFF”. Though the VDD voltage would be going up to a higher level than Vdet1 if it is within a time period of the output delay time, VD1 would not be output a signal for turning

#### **Reset conditions from overcharging**

There can be two cases to reset the VD1 making the Cout pin level to “H” again after detecting overcharge. Resetting the VD1 makes the charging system ready for resumption of charging process.

The first case is in such condition that a time when the VDD voltage is coming down to a level lower than “Vdet1-Vhys1”. While in the second case, disconnecting a charger from the battery pack can make the VD1 resetting when

#### **VD2/Over-Discharge Detector**

The VD2 monitors a VDD pin voltage. When the VDD voltage crosses the over-discharge detector threshold Vdet2 from a high value to a value lower than the Vdet2, the VD2 can sense an over-discharging and the external discharge control Nch-MOS-FET turns to “OFF” with Dout pin being at “L”.

Resetting the VD2 with the Dout pin level being “H” again after detecting over-discharge is only possible by connecting a charger to the battery VDD voltage is higher than Vdet2.

An output delay time for the over-discharge detection is fixed internally. Through the VDD voltage would be going down to a lower level than Vdet2 if it is within a time period of the output delay time, VD2 would not output a signal for turning “OFF” of discharge control

#### **VD3/Excess Current Detector, Short Circuit Protector**

Both of the excess current detector and short

“OFF” of charge control Nch-MOS-FET.

A level shifter incorporated in a buffer driver for the Cout pin makes the “L” of Cout pin to the VM pin voltage and the “H” of Cout pin is set to VDD voltage with CMOS buffer.

the VDD level is within hysteresis width ( $V_{det1} - V_{hys1} \leq VDD < V_{det1}$ )

After detecting over-charge with the VDD voltage of higher than Vdet1, connecting system load to the battery pack makes load current allowable through parasitic diode of external charge control Nch-MOS-FET. The Cout level would be “H” when the VDD level is coming down to a level below the Vdet1 by continuous drawing of load current.

pack. When the VDD voltage stays under over-discharge detector threshold Vdet2 charge current can flow through parasitic diode of external control Nch-MOS-FET, then after the VDD voltages comes up to a value larger than Vdet2 discharging process would be advanced through “ON” state discharge control Nch-MOS-FET. Connecting a charger to the battery pack makes the Dout level being “H” instantaneously when the Nch-MOS-FET.

After detection of an over-discharge by VD2, supply current would be reduced to 0.3uA TYP. At VDD=2V and into standby, only the charger detector is operating.

The output type of Dout pin is CMOS having “H” level of VDD and “L” level of VSS.

circuit protector can work when both control

Nch-MOS-FET are in “ON” state. When VM pin voltage is going up to a value between the short protection voltage Vshort and excess current threshold Vdet3, the excess current detector operates and further soaring of VM pin voltage higher than Vshort makes the short circuit protector enabled. As a result the external discharge control Nch-MOS-FET turns to “OFF” with Dout pin being at “L”. An output delay time for the excess current detector is internally fixed, about 13ms TYP. At VDD=3V. A quick recovery of VM pin level from a value between Vshort and Vdet3 within the delay time keeps the discharge control FET staying “ON” state. When the short circuit protector is enabled, the Dout would be “L” and its delay time would be 5us TYP.

The VM pin has a built-in pull down resistor, TYP. 100K Ohm, connected to the VSS pin. After an excess current or a short circuit protection is detected, removing a cause of excess current or external short circuit makes an external discharge control Nch-MOS-FET to an “ON” state automatically with the VM pin level being down to the VSS level through the built-in pull down resistor. When VDD voltage is higher than Vdet2 at a time when the excess current is detected the T63H0001A does not enter a standby mode, while VDD voltage is lower than Vdet2 the T63H0001A enters a standby mode. After detecting short circuit the T63H0001A will not enter a standby mode.

**Application Circuits**

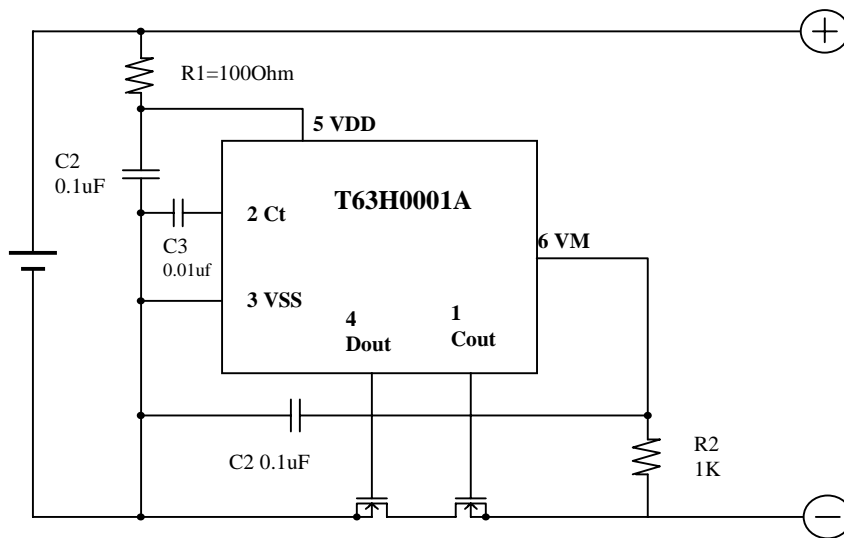

**PACKAGE DIMENSION (Unit: mm)**  
**SOT-23-6**

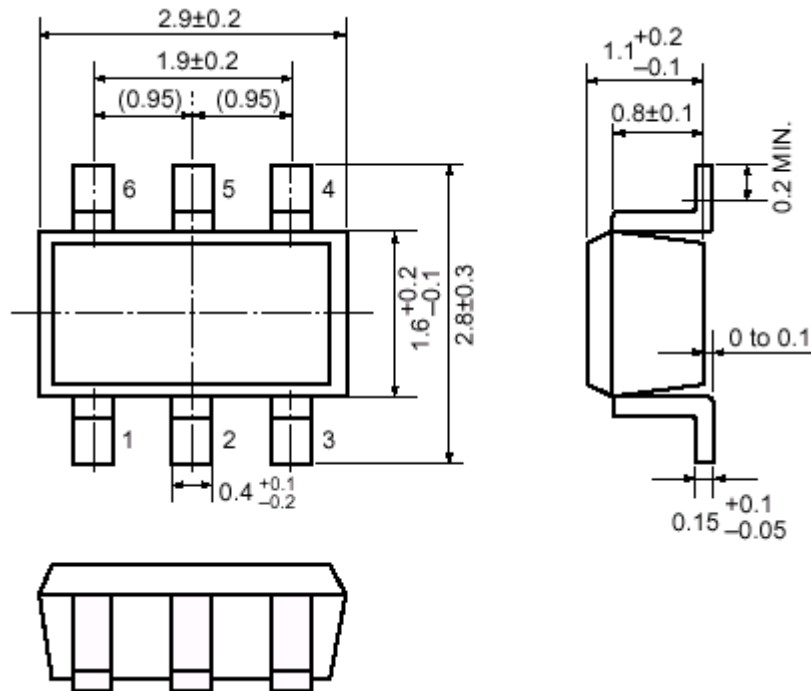

**TAPING SPECIFICATION (Unit: mm)**  
**SOT-23-6**

