

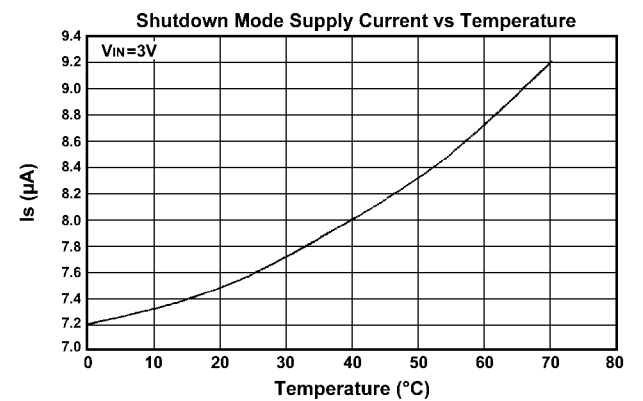
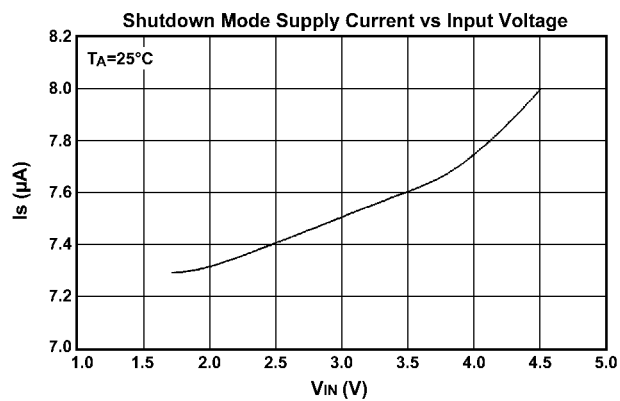
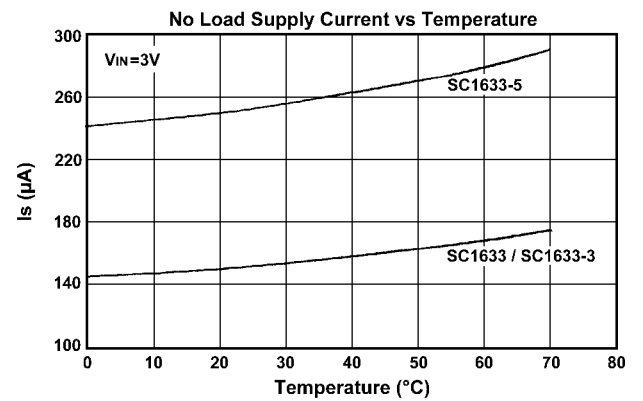
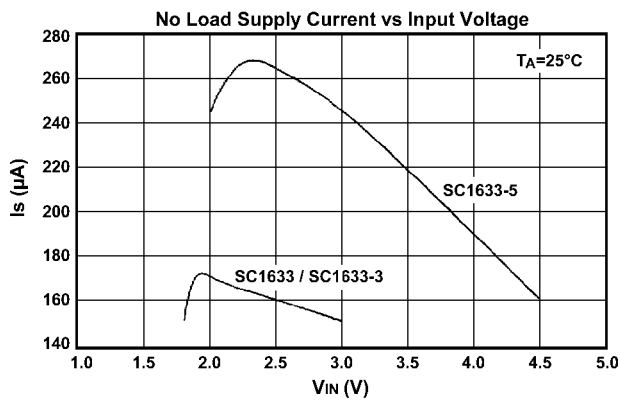
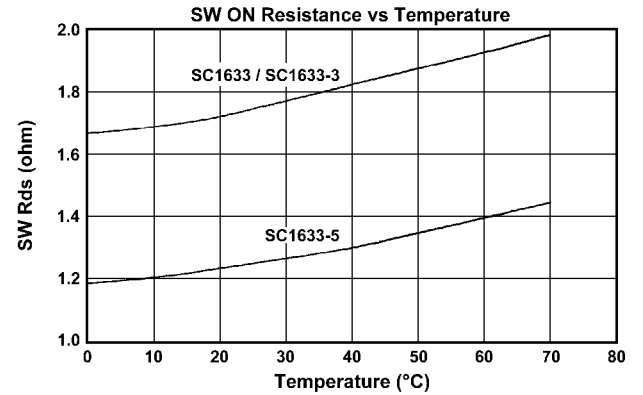
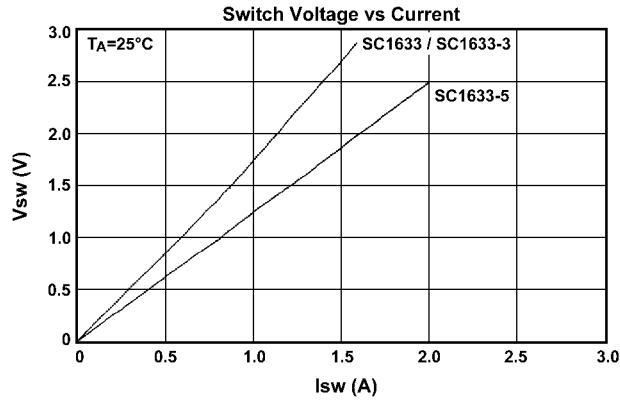
January 29, 1998

ELECTRICAL CHARACTERISTICS

 Unless otherwise specified, $T_A = 25^\circ\text{C}$, $V_{IN} = 3.0\text{V}$

Parameter	V_{IN}	I_L	Min	Typ	Max	Units
Input Voltage			1.8		7.0	V
Output Voltage SC1633 SC1633-3 SC1633-5		$I_L = 70\text{mA}$	3.16 2.88 4.80	3.30 3.00 5.00	3.44 3.12 5.20	V
Switch Off Current				105	140	μA
No Load Current SC1633/SC1633-3 SC1633-5				160 250		μA
Shutdown Mode Current				7	15	μA
Shutdown Recovery Time	$V_{IN}=2.5\text{V}$	$I_L=70\text{mA}$		1.8		msec
Efficiency SC1633/SC1633-3 SC1633-5		$I_L=70\text{mA}$		87 86		%
Line Regulation SC1633 SC1633-3 SC1633-5	$V_{IN}=2.0 - 3.3\text{V}$ $V_{IN}=2.0 - 3.0\text{V}$ $V_{IN}=2.2 - 4.5\text{V}$	$I_L=40\text{mA}$		0.6 0.6 0.5		$\%V_{OUT}$
Load Regulation SC1633/SC1633-3 SC1633-5		$I_L=1\text{mA} - 70\text{mA}$		0.6 0.5		$\%V_{OUT}$
Oscillator Frequency			90	120	150	kHz
LBI Pin Trip Point			1.17	1.22	1.27	V
LBO "On Resistance"	$V_{IN} = 2\text{V}$			45		Ω
SW "On Resistance" SC1633/SC1633-3 SC1633-5				1.75 1.25		Ω
SW Off Leakage					1	μA
Input Pin Bias Current					10	nA/Pin
Output Pin Leakage					10	nA/Pin

January 29, 1998

TYPICAL PERFORMANCE CHARACTERISTICS


January 29, 1998

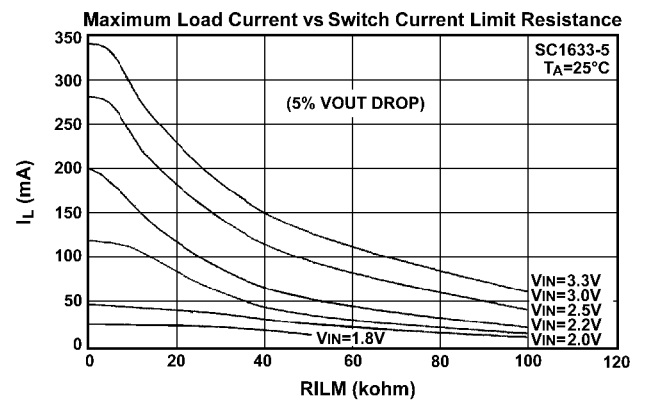
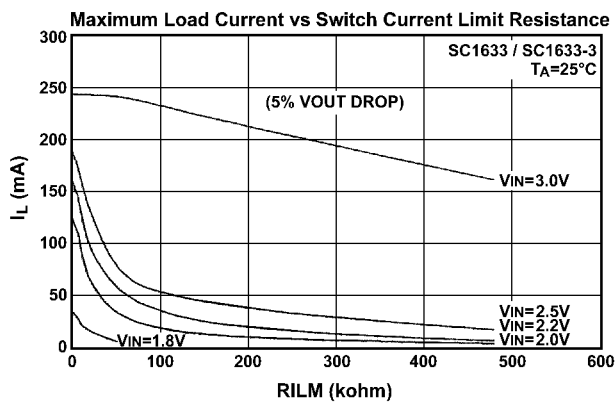
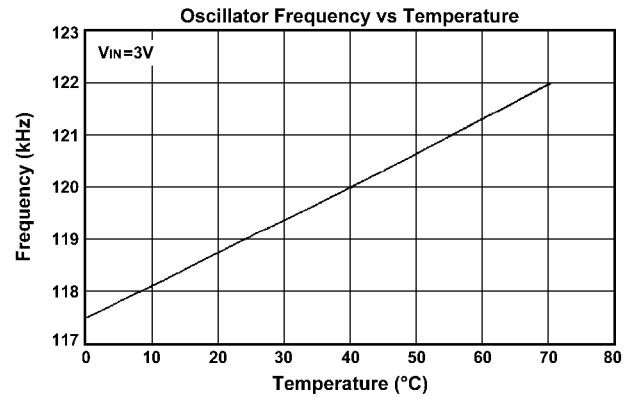
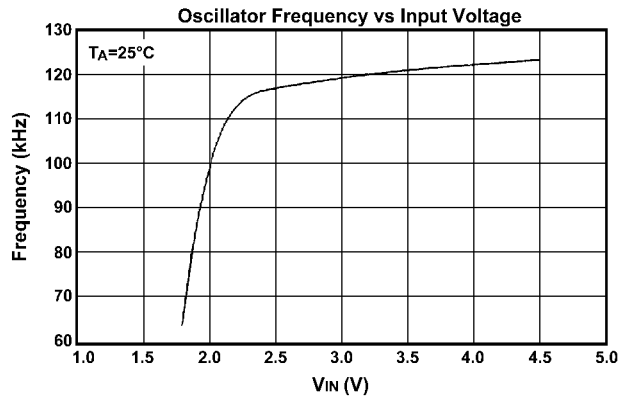
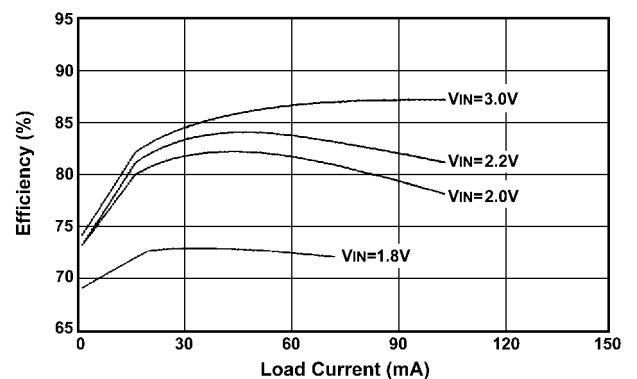
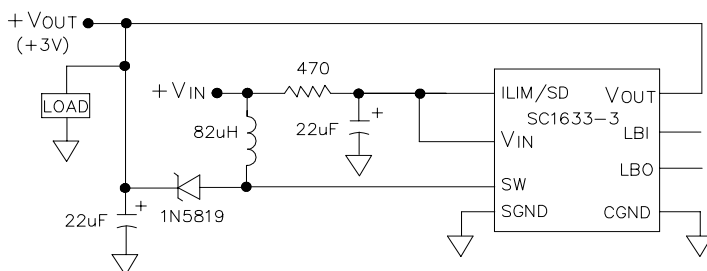
TYPICAL PERFORMANCE CHARACTERISTICS (cont.)

APPLICATION EXAMPLES


Figure 1. 3V Output Step-Up Converter

January 29, 1998

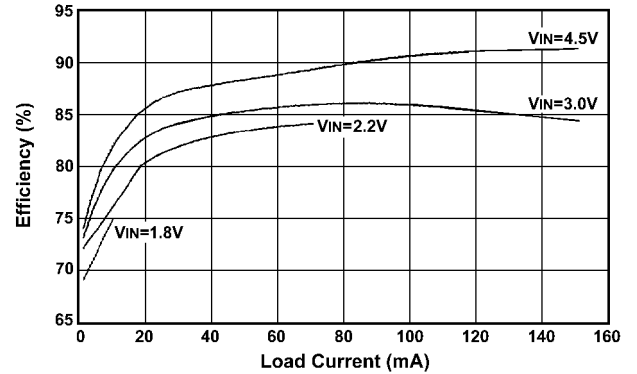
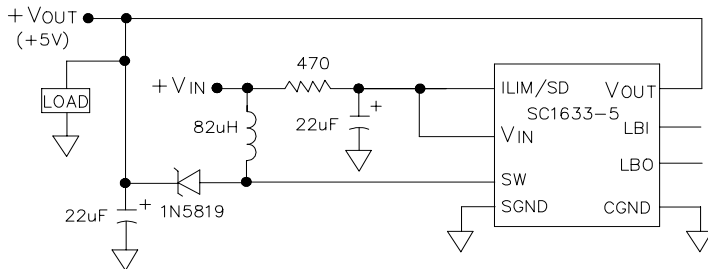
APPLICATION EXAMPLES (cont.)


Figure 2. 5V Output Step-Up Converter

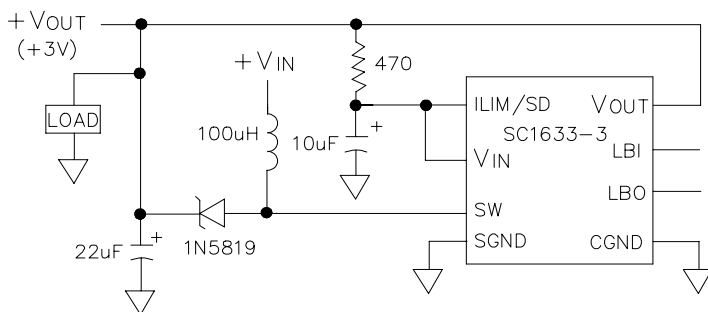
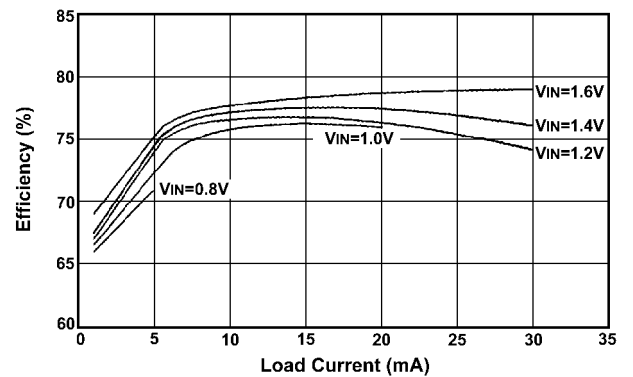

 Start-up V_{IN} Voltage = 1.4V


Figure 3. 1-Cell Input 3V Output Step-Up Converter

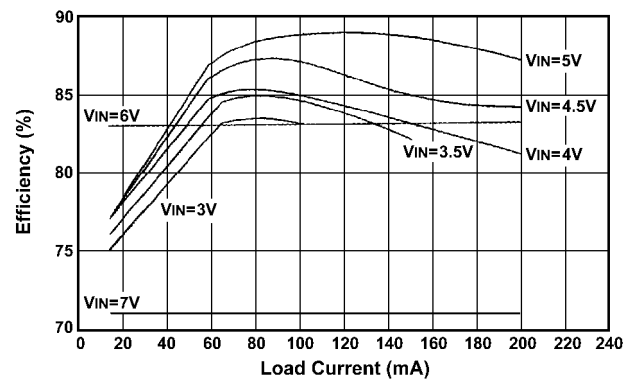
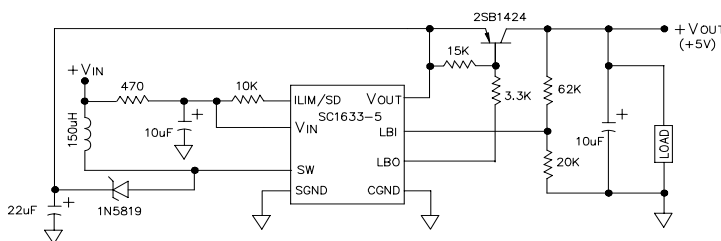
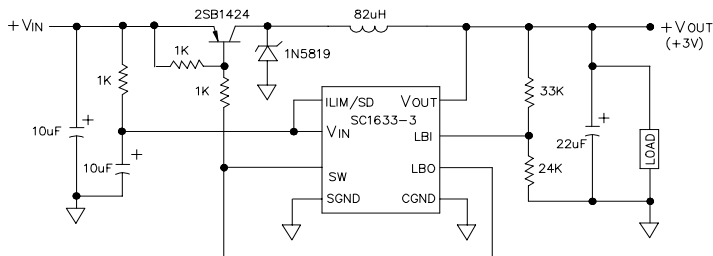


Figure 4. 4-Cell Input Step-Up/Step-Down Converter

January 29, 1998

APPLICATION EXAMPLES (cont.)


V_{OUT} Ripple may be large at $V_{IN}=3V$ condition

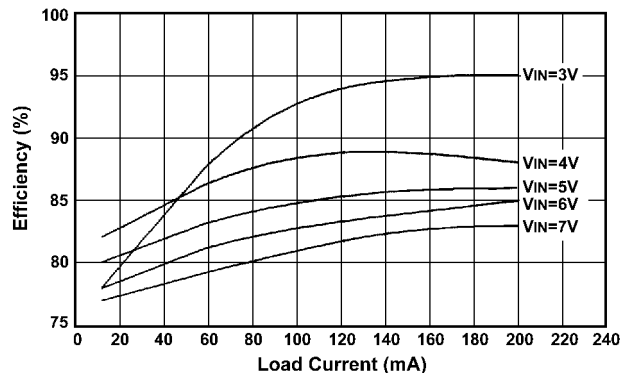


Figure 5. 3-Cell Input 3V Output Step-Down Converter

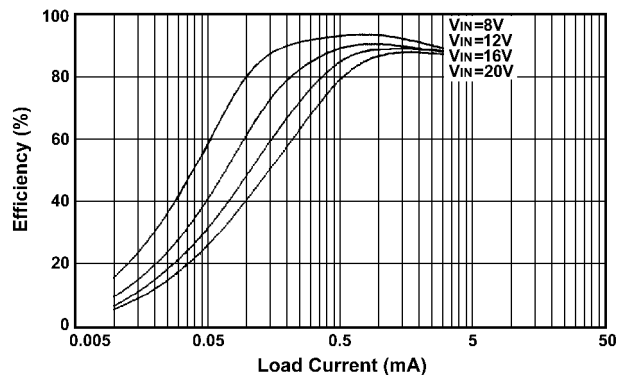
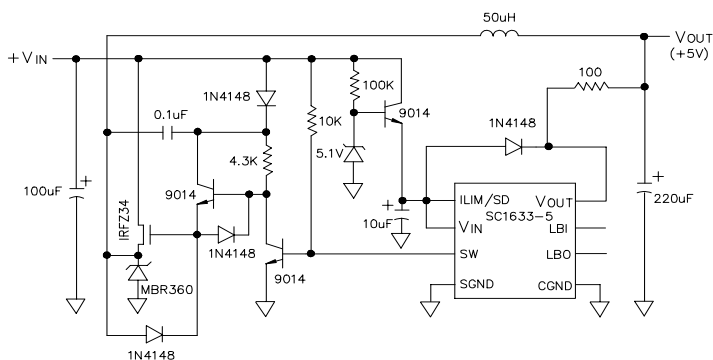
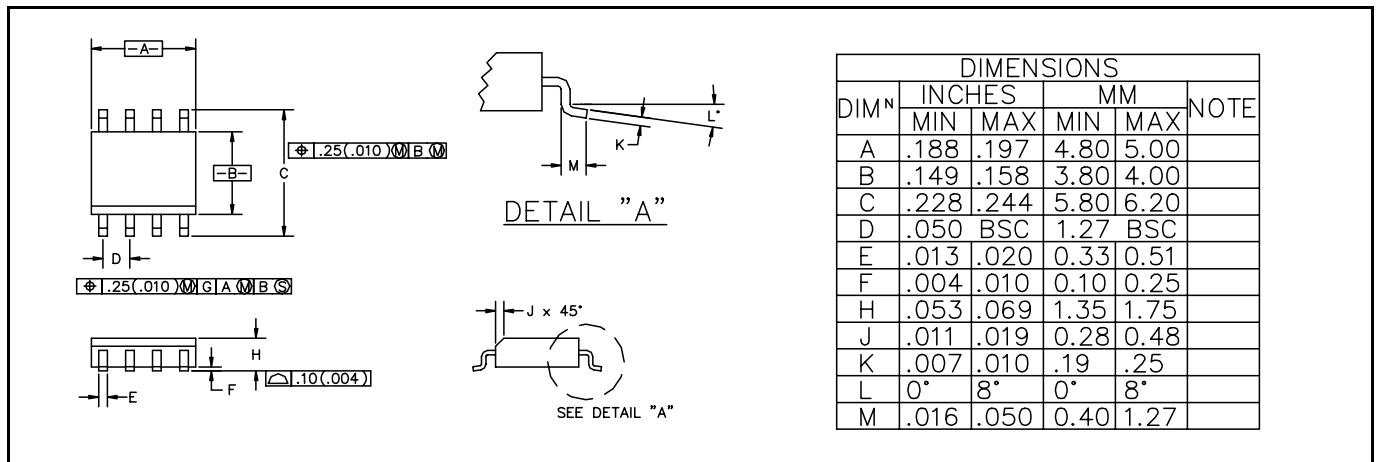


Figure 6. Boost-Drive 5V Output Step-Down Converter

January 29, 1998

DEVICE OUTLINE - SO-8

PIN DESCRIPTIONS

PIN 1: I_{LIM}/SD (1) Connected to V_{IN} pin through a resistor to set the switch peak current. It serves to protect the IC and inductor, as well as to improve efficiency and output ripple. However, the supply capability of the SC1633 is limited by the current limit resistor (see typical performance characteristics). The I_{LIM}/SD pin should be shorted to V_{IN} if limiting switch peak current is not required.
 (2) The SC1633 goes into shutdown mode and consumes less than 10 μ A when the I_{LIM}/SD pin is pulled to ground.

PIN 2: V_{IN} Input supply.

PIN 3: SW Drain of the power switch, to be connected to the inductor and diode.

PIN 4: SGND Ground connected to the source of the power switch.

PIN 5: CGND Ground for control circuits of the IC. It should be separated from SGND to avoid interference.

PIN 6: LBO Open drain output of the battery low detector, with 45 Ohm "On Resistance" at $V_{IN}=2V$. It is pulled low when the voltage on the LBI pin is below 1.22 volts.

PIN 7: LBI The inverting input of the battery low detector, of which the non-inverting input is internally connected to the 1.22V voltage reference.

PIN 8: V_{OUT} The output voltage feeds back to the IC through this pin.

PIN CONFIGURATION
