

MSARS50S20X,Y
MSARS50S20RX,Y

Features

- passivated mesa structure for very low leakage currents
- Epitaxial structure minimizes forward voltage drop
- Hermetically sealed, low profile ceramic (MSARS50S20Y and MSARS50S20RY) or glass (MSARS50S20X and MSARS50S20RX) surface mount power package
- Low package inductance
- Very low thermal resistance
- Available as standard polarity (strap-to-anode, MSARS50S20X, Y) and reverse polarity (strap-to-cathode: MSARS50S20RX, Y)

200 Volts
50 Amps
2 ns

LOW VOLTAGE
DROP STANDARD
RECTIFIER

Maximum Ratings @ 25°C (unless otherwise specified)

DESCRIPTION	SYMBOL	MAX.	UNIT
Peak Repetitive Reverse Voltage	V_{RRM}	200	Volts
Working Peak Reverse Voltage	V_{RWM}	200	Volts
DC Blocking Voltage	V_R	200	Volts
Average Rectified Forward Current, $T_c \leq 125^\circ\text{C}$	$I_{F(ave)}$	50	Amps
Nonrepetitive Peak Surge Current, $t_p = 8.3$ ms, half-sinewave	I_{FSM}	375	Amps
Junction Temperature Range	T_j	-65 to +175	$^\circ\text{C}$
Storage Temperature Range	T_{stg}	-65 to +175	$^\circ\text{C}$
Thermal Resistance, Junction to Case:	θ_{JC}	1.0	$^\circ\text{C/W}$

Mechanical Outline

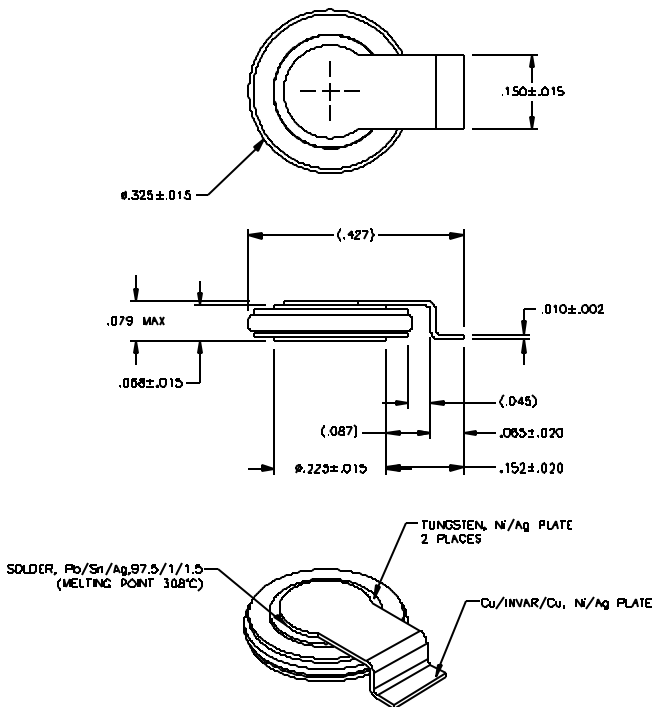

MSARS50S20Y & RY (Slugger)

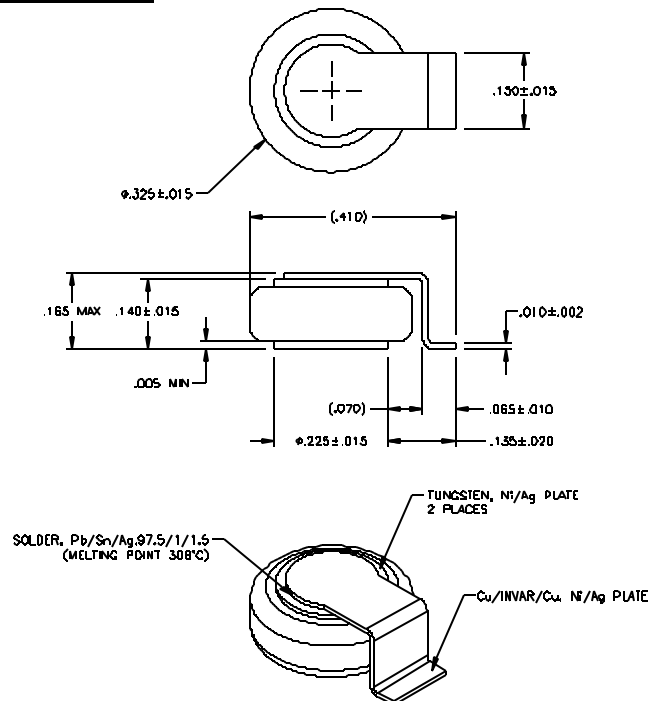

MSARS50S20X & RX (X-BODY)

MSARS50S20X,Y**MSARS50S20RX,Y****Electrical Parameters***PRELIMINARY*

DESCRIPTION	SYMBOL	CONDITIONS	MIN	TYP.	MAX	UNIT
Reverse (Leakage) Current	IR ₂₅	VR= 200 Vdc, Tc= 25°C		1	10	μA
	IR ₁₂₅	VR= 200 Vdc, Tc= 125°C		2	0.3	mA
Forward Voltage pulse test, pw= 300 μs d/c≤ 2%	VF1	IF= 5 A, Tc= 25°C		810	840	mV
	VF2	IF= 10 A, Tc= 25°C		835	875	mV
	VF3	IF= 25 A, Tc= 25°C		875	925	mV
	VF4	IF= 50 A, Tc= 25°C		915	975	mV
	VF5	IF= 100 A, Tc= 25°C		975	-	mV
	VF6	IF= 5 A, Tc= -55°C		910	950	mV
	VF7	IF= 10 A, Tc= -55°C		930	1000	mV
	VF8	IF= 25 A, Tc= -55°C		970	1050	mV
	VF9	IF= 50 A, Tc= -55°C		1000	1100	mV
	VF10	IF= 5 A, Tc= 125°C		675	725	mV
	VF11	IF= 10 A, Tc= 125°C		710	775	mV
	VF12	IF= 25 A, Tc= 125°C		760	825	mV
	VF13	IF= 50 A, Tc= 125°C		800	875	mV
Junction Capacitance	Cj1	VR= 10 Vdc		300	400	pF
	Cj2	VR= 5 Vdc		400	-	pF
Breakdown Voltage	BVR	IR= 500 μA, Tc= 25°C	220	250	n/a	V
Reverse Recovery Time	trr	IF= .5 A, IR= 1 A, IRR= .25 A		1	2	μs

VF(If) typical

