

- 1N5822US AVAILABLE IN JAN, JANTX, JANTXV AND JANS PER MIL-PRF-19500/620
- 3 AMP SCHOTTKY BARRIER RECTIFIERS
- HERMETICALLY SEALED
- LEADLESS PACKAGE FOR SURFACE MOUNT
- METALLURGICALLY BONDED, DOUBLE PLUG CONSTRUCTION

1N5820US  
thru  
1N5822US

## MAXIMUM RATINGS

Operating Temperature: -65°C to +125°C  
Storage Temperature: -65°C to +150°C  
Average Rectified Forward Current: 3.0 AMP,  $T_{EC} = +55^{\circ}C$   
Derating: 43 mA / °C above  $T_{EC} = +55^{\circ}C$

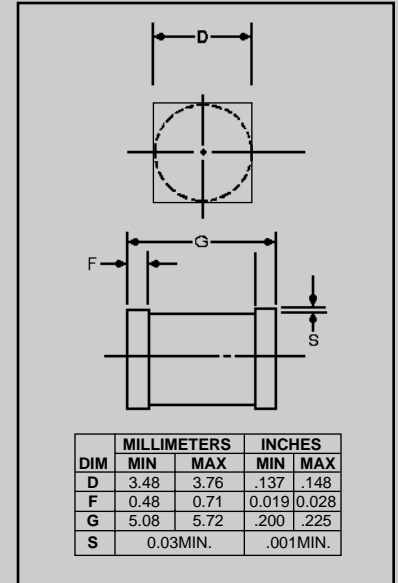

FIGURE 1

ELECTRICAL CHARACTERISTICS @ 25°C, unless otherwise specified.

CDI TYPE NUMBER	WORKING PEAK REVERSE VOLTAGE	MAXIMUM FORWARD VOLTAGE			MAXIMUM REVERSE LEAKAGE CURRENT AT RATED VOLTAGE		
		$V_{RWM}$	$V_F @ 1.0A$	$V_F @ 3.0A$	$V_F @ 9.4A$	$I_R @ 25^{\circ}C$	$I_R @ 100^{\circ}C$
		VOLTS	VOLTS	VOLTS	VOLTS	mA	mA
1N5820US	20	0.40	0.50	0.70	0.10	12.5	
1N5821US	30	0.40	0.50	0.70	0.10	12.5	
1N5822US	40	0.40	0.50	0.70	0.10	12.5	
J,JX, JV & JS 5822US	40	0.40	0.50	0.70	0.10	12.5	

## DESIGN DATA

**CASE:** D-5B, Hermetically sealed glass case, PER MIL-PRF 19500/620

**LEAD FINISH:** Tin / Lead

**THERMAL RESISTANCE:** ( $R_{\theta JC}$ ):  
10  $\mu C/W$  maximum at  $L = 0$  inch

**THERMAL IMPEDANCE:** ( $Z_{\theta JX}$ ): 3  
 $\mu C/W$  maximum

**POLARITY:** Cathode end is banded.

**MOUNTING SURFACE SELECTION:**  
The Axial Coefficient of Expansion (COE) of this device is approximately + 4PPM / °C. The COE of the Mounting Surface System should be selected to provide a suitable match with this device.



# 1N5820US thru 1N5822US

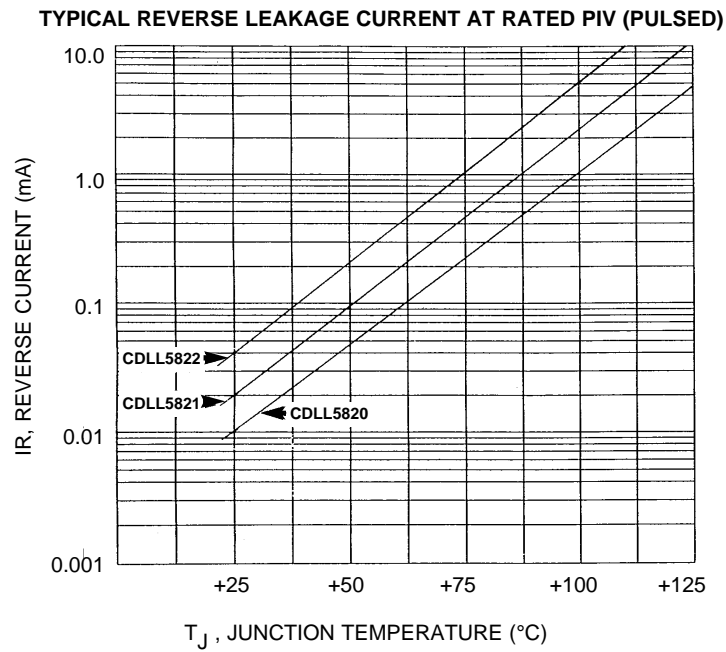

FIGURE 1

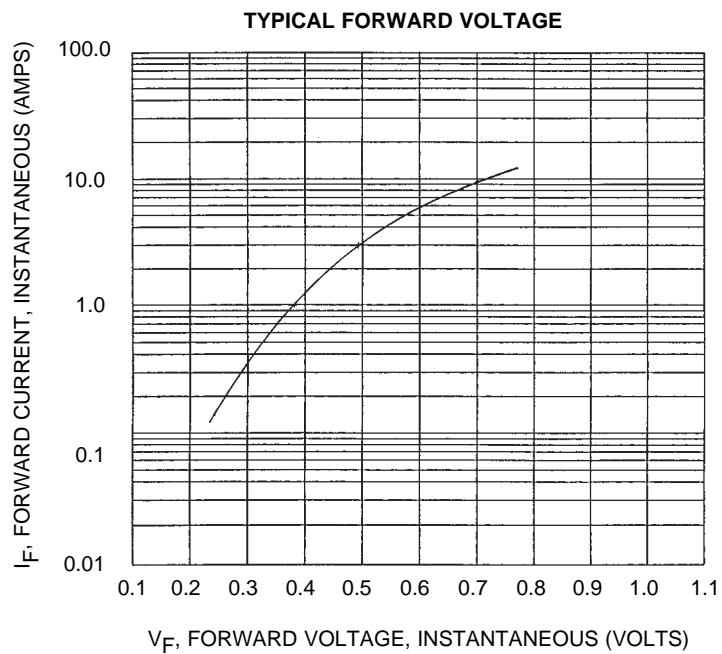

FIGURE 2