



# Obsolescence Notice

This product is obsolete.

This information is available for your convenience only.

For more information on Zarlink's obsolete products and replacement product lists, please visit

[http://products.zarlink.com/obsolete\\_products/](http://products.zarlink.com/obsolete_products/)

# ZN409CE

## PRECISION SERVO INTEGRATED CIRCUIT

The ZN409CE is a precision monolithic integrated circuit designed particularly for pulse-width position servo mechanisms used in all types of control applications. The low number of components required with the ZN409CE, together with its low power consumption, make this integrated circuit ideal for use in model aircraft, boats and cars where space, weight and battery life are at a premium. The amplifier will operate over a wide range of repetition rates and pulse widths and is therefore suitable for the majority of systems. The ZN409CE can also be used in motor speed control circuits.

### FEATURES

- Low External Component Count
- Low Quiescent Current (7mA Typical at 4.8V)
- Excellent Voltage and Temperature Stability
- High Output Drive Capability
- Consistent and Repeatable Performance
- Precision Internal Voltage Stabilisation
- Time Shared Error Pulse Expansion
- Balanced Deadband Control
- Schmitt Trigger Input Shaping
- Reversing Relay Output (DC Motor Speed Control)

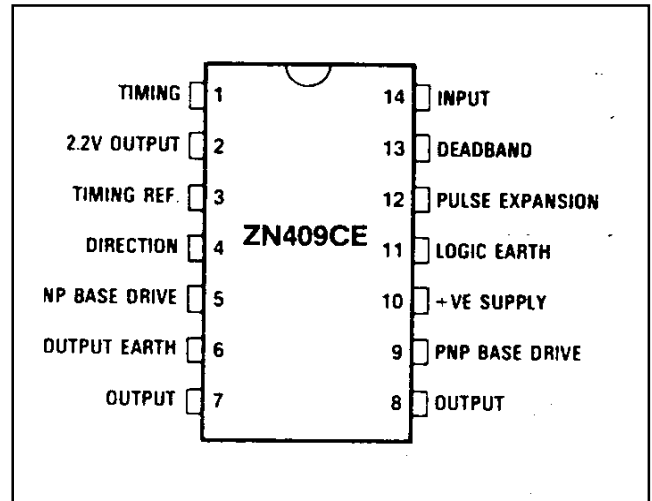

Fig.1 Pin connections - top view

### ABSOLUTE MAXIMUM RATINGS

Supply voltage	6.5V
Package dissipation	300mW
Operating Temperature range	-20°C to +65°C
Storage temperature range	-65°C to +150°C

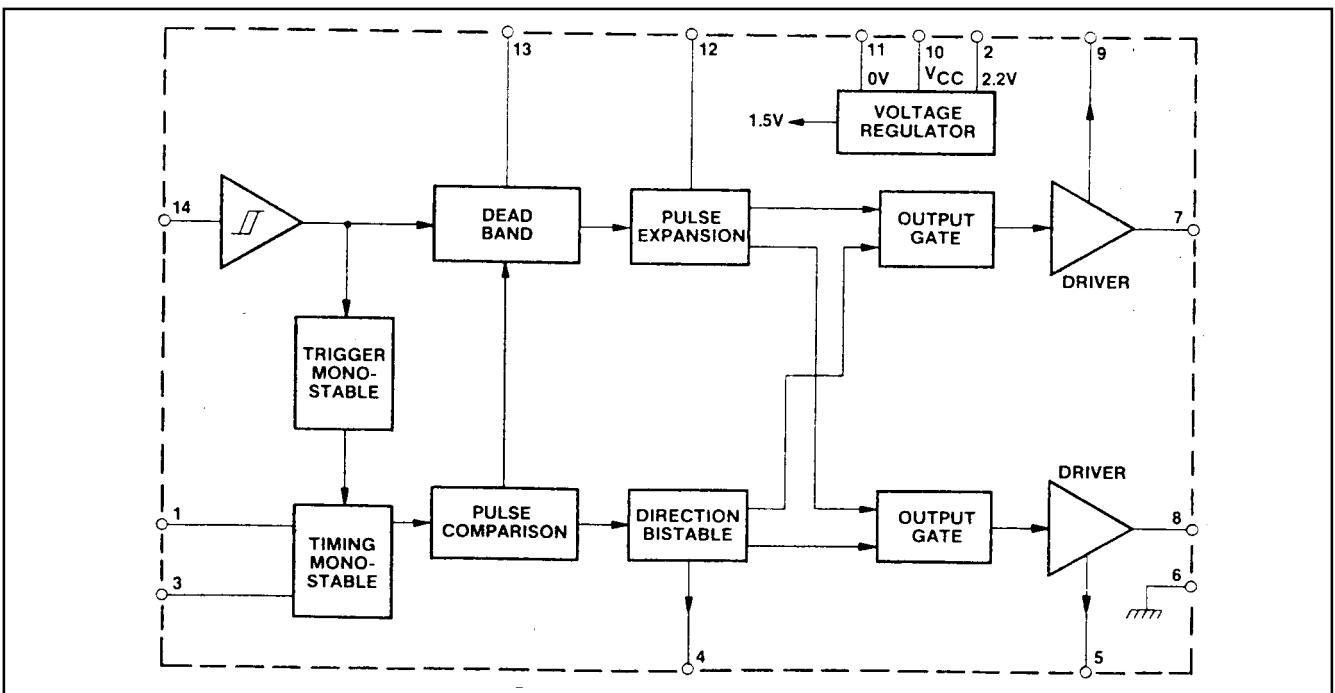

Fig.2 Block diagram for ZN409CE

## ZN409CE

### ELECTRICAL CHARACTERISTICS

Test conditions (unless otherwise stated):

$$T_{amb} = 25^{\circ}\text{C}, V_s = 5\text{V}$$

Characteristics	Value			Units	Test conditions
	Min.	Typ.	Max.		
Input threshold (lower)	1.15	1.25	1.35	V	Pin 14
Input threshold (upper)	1.4	1.5	1.6	V	Pin 14
Ratio upper/lower threshold	1.1	1.2	1.3		-10°C to +65°C
Input resistance	20	27	35	k $\Omega$	
Input current	350	500	650	$\mu\text{A}$	
Regulator voltage	2.1	2.2	2.3	V	-10°C to +65°C, 1.3mA load current
Regulator supply rejection ratio	200	300	-		$V_s = 3.5\text{V to } 6.5\text{V}$ $dV_{IN}$ $RSRR = \frac{dV_{OUT}}{dV_{IN}}$
Monostable Linearity	-	3.5	4.0	%	$\pm 45^{\circ}$ , $R_p = 1.5\text{k}\Omega$ , $R_1 = 12\text{k}\Omega$
Monostable period temperature coefficient	-	+0.01	-	%/°C	Excluding $R_T$ , $C_T$ . $R_p = 1.5\text{k}\Omega$ , $R_1 = 12\text{k}\Omega$ (potentiometer slider set mid-way)
Output Schmitt deadband	$\pm 1$	$\pm 1.5$	$\pm 3$	$\mu\text{s}$	$C_E = 0.47\mu\text{F}$
Minimum output pulse	2.5	3.5	4.5	ms	$C_E = 0.47\mu\text{F}$ , $R_E = 180\text{k}\Omega$
Error pulse for full drive	70	100	130	$\mu\text{s}$	15ms repetition rate $C_E = 0.47\mu\text{F}$ , $R_E = 180\text{k}\Omega$
Total deadband	$\pm 3.5$	$\pm 5$	$\pm 6.5$	$\mu\text{s}$	$C_D = 1000\text{pF}$
PNP drive	40	55	70	mA	$T = 25^{\circ}\text{C}$
	35	50	65	mA	$T = 10^{\circ}\text{C}$
Output saturation voltage	-	300	400	mV	$I_L = 400\text{mA}$
Direction bistable output	2	2.8	3.6	mA	
Supply voltage range	3.5	5	6.5	V	
Supply current	4.6	6.7	10	mA	Quiescent
Total external current from regulator	1.3	-	-	mA	$V_s = 3.5\text{V}$
Peak voltage $V_{C\_EXT}$ (with respect to 2V regulated voltage)	-	0.7	-	V	$T = 25^{\circ}\text{C}$
	-	0.5	-	V	$T = -10^{\circ}\text{C}$

### CIRCUIT DESCRIPTION

The ZN409CE incorporates a precision dual voltage source providing 1.5V for internal use and 2.2V for external circuit requirements.

The input circuit is a Schmitt trigger allowing servo operation independent of edge speed, as obtained from the receiver-decoder.

Output from the Schmitt trigger is fed to the deadband and monostable circuits. The deadband circuit provides a programmable area of insensitivity to input pulse in order to eliminate hunting and overshoot. Dynamic feedback can be

used to reduce the width of the deadband to acceptable levels, and to maintain correct servo operation.

The monostable circuits provide the inputs to the pulse comparison circuit which determines direction and amount of drive required to reach the new position. The output drive is also controlled by the pulse expansion circuit. This circuit ensures that a stationary motor will start rotating without drawing full stall current. This gives much improved battery life.





HEADQUARTERS OPERATIONS  
**GEC PLESSEY SEMICONDUCTORS**  
Cheney Manor, Swindon,  
Wiltshire SN2 2QW, United Kingdom.  
Tel: (0793) 518000  
Fax: (0793) 518411

**GEC PLESSEY SEMICONDUCTORS**  
P.O. Box 660017  
1500 Green Hills Road,  
Scotts Valley, California 95067-0017,  
United States of America.  
Tel: (408) 438 2900  
Fax: (408) 438 5576

CUSTOMER SERVICE CENTRES

- **FRANCE & BENELUX** Les Ulis Cedex Tel: (1) 64 46 23 45 Fax : (1) 64 46 06 07
- **GERMANY** Munich Tel: (089) 3609 06-0 Fax : (089) 3609 06-55
- **ITALY** Milan Tel: (02) 66040867 Fax: (02) 66040993
- **JAPAN** Tokyo Tel: (03) 5276-5501 Fax: (03) 5276-5510
- **NORTH AMERICA Integrated Circuits and Microwave Products** Scotts Valley, USA  
Tel (408) 438 2900 Fax: (408) 438 7023.  
**Hybrid Products**, Farmingdale, USA Tel (516) 293 8686 Fax: (516) 293 0061.
- **SOUTH EAST ASIA** Singapore Tel: (65) 3827708 Fax: (65) 3828872
- **SWEDEN** Stockholm, Tel: 46 8 702 97 70 Fax: 46 8 640 47 36
- **UK, EIRE, DENMARK, FINLAND & NORWAY**  
Swindon Tel: (0793) 518510 Fax : (0793) 518582

These are supported by Agents and Distributors in major countries world-wide.

© GEC Plessey Semiconductors 1993 Publication No. DS3894 Issue No. 2.0 October 1993