

Features

- Extremely low collector-to-emitter saturation voltage
($V_{CE(SAT)} = -0.15V$ Typ. @ $I_C/I_B = -100mA/-10mA$)
- Suitable for low voltage large current drivers
- Complementary pair with DN030
- Switching Application

Ordering Information

Type NO.	Marking	Package Code
DP030	DP030	TO-92

Outline Dimensions

unit : mm

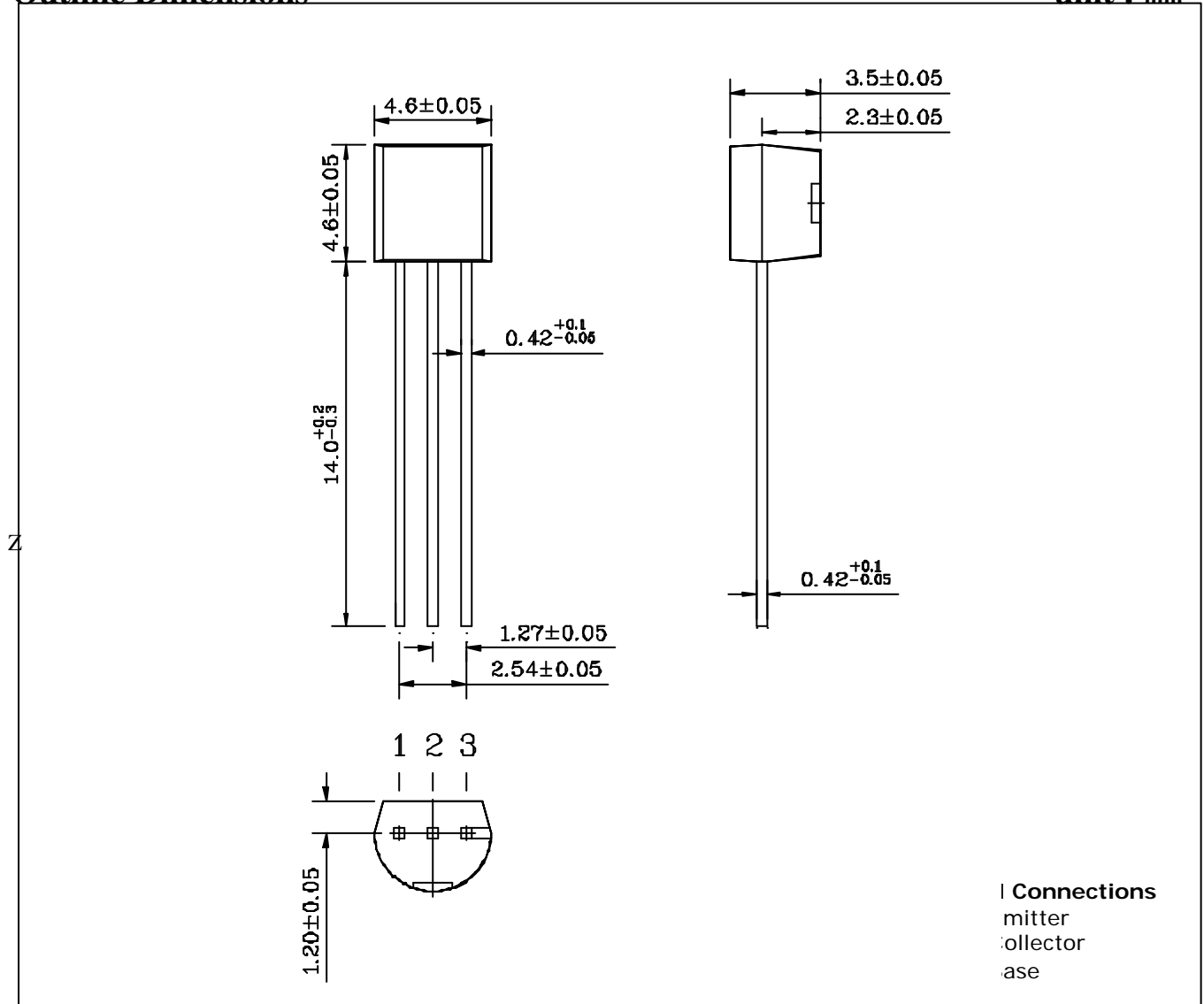

Absolute maximum ratings

(Ta=25° C)

Characteristic	Symbol	Ratings	Unit
Collector-Base voltage	V_{CBO}	-15	V
Collector-Emitter voltage	V_{CEO}	-12	V
Emitter-Base voltage	V_{EBO}	-5	V
Collector current	I_C	-300	mA
Collector dissipation	P_C	625	mW
Junction temperature	T_J	150	°C
Storage temperature	T_{stg}	-55 ~ 150	°C

Electrical Characteristics

(Ta=25° C)

Characteristic	Symbol	Test Condition	Min.	Typ.	Max.	Unit
Collector-Base breakdown voltage	BV_{CBO}	$I_C = -50\mu A, I_E = 0$	-15	-	-	V
Collector-Emitter breakdown voltage	BV_{CEO}	$I_C = -1mA, I_B = 0$	-12	-	-	V
Emitter-Base breakdown voltage	BV_{EBO}	$I_E = -50\mu A, I_C = 0$	-5	-	-	V
Collector cut-off current	I_{CBO}	$V_{CB} = -12V, I_E = 0$	-	-	-0.1	μA
Emitter cut-off current	I_{EBO}	$V_{EB} = -5V, I_C = 0$	-	-	-0.1	μA
DC current gain	h_{FE1}	$V_{CE} = -1V, I_C = -100mA$	200	-	450	-
	h_{FE2}	$V_{CE} = -1V, I_C = -300mA$	70	-	-	-
Collector-Emitter saturation voltage	$V_{CE(sat1)}$	$I_C = -100mA, I_B = -10mA$	-	-	-0.2	V
	$V_{CE(sat2)}$	$I_C = -300mA, I_B = -30mA$	-	-	-0.5	V
Base-Emitter saturation voltage	$V_{BE(sat1)}$	$I_C = -100mA, I_B = -10mA$	-	-	-1.2	V
	$V_{BE(sat2)}$	$I_C = -300mA, I_B = -30mA$	-	-	-1.7	V
Transition frequency	f_T	$V_{CE} = -5V, I_C = -10mA$	-	350	-	MHz
Collector output capacitance	C_{ob}	$V_{CB} = -10V, I_E = 0, f = 1MHz$	-	4	-	pF

Electrical Characteristic Curves

Fig. 1 $P_C - T_a$

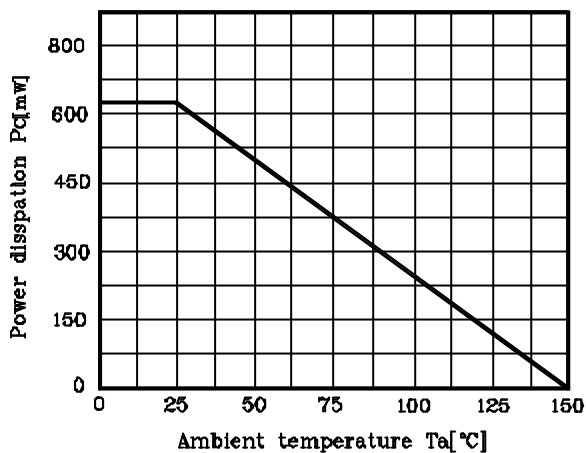

Fig. 2 $I_C - V_{BE}$

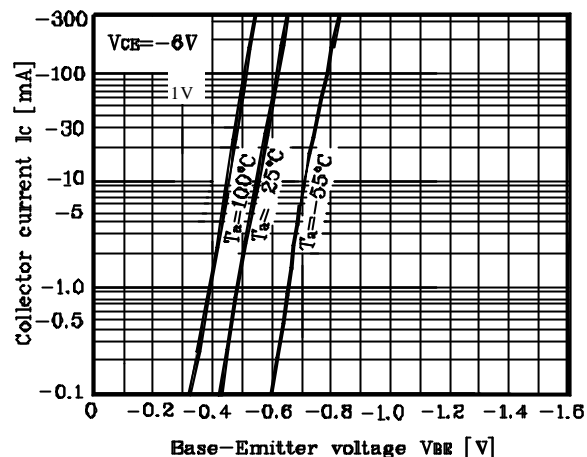

Fig. 3 $h_{FE} - I_C$

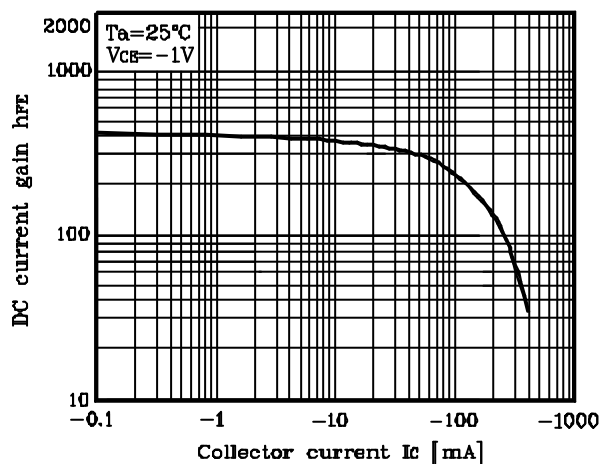

Fig. 4 $I_C - V_{CE}$

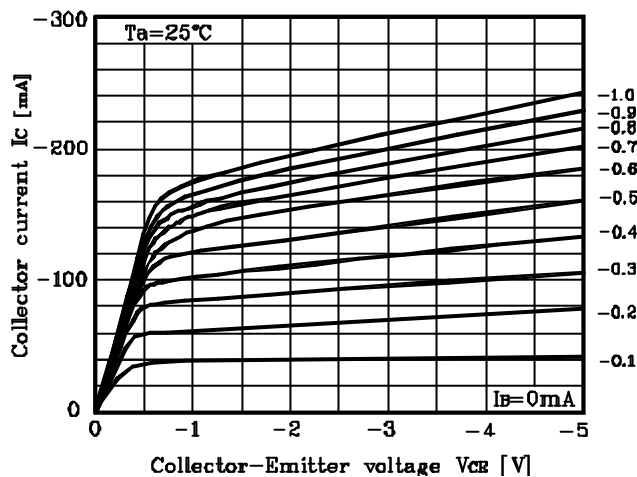

Fig. 5 $V_{CE(sat)} - I_C$

