



Design Example Report

Title	<i>21W (45W peak) Multiple Output Power Supply using TOP246Y</i>
Specification	Input: 90 – 265 VAC Output: 12V / 0.72A (2.75A _{PK}), 5V / 1.4A, 3.3V / 1.51A, 3V / 0.1A, -22V/4mA
Application	DVD Recorder with HDD
Author	Power Integrations Applications Department
Document Number	DER-40
Date	February 22, 2005
Revision	3.0

Summary and Features

- No linear regulators used
- One transformer solution
- Small 6.8 mH common mode choke, small X-cap and Y-cap
- EMI has 12 dB margin
- Good cross regulation
- Small heatsinks
- Good peak power capability (can operate down to 75 Vac)
- EEL25 transformer does not use triple insulated wire, or Teflon sleeving
- Meets low power standby requirements

The products and applications illustrated herein (including circuits external to the products and transformer construction) may be covered by one or more U.S. and foreign patents or potentially by pending U.S. and foreign patent applications assigned to Power Integrations. A complete list of Power Integrations' patents may be found at www.powerint.com.

Table Of Contents

1	Introduction	4
2	Photograph.....	4
3	Power Supply Specification.....	5
4	Schematic	6
5	Circuit Description	8
5.1	Input EMI Filtering	8
5.2	TOPSwitch Primary.....	8
5.3	Outputs.....	8
5.4	Output Feedback.....	8
5.5	Rev 2 to Rev3 changes	9
6	PCB Layout	10
7	Bill Of Materials	11
8	Transformer Specification	13
8.1	Electrical Diagram	13
8.2	Electrical Specifications	13
8.3	Materials.....	14
8.4	Transformer Build Diagram	14
8.4.1	WD#3 Copper Foil build diagram:.....	15
8.4.2	WDG#4 & #5 Copper Foil build diagram:.....	15
8.5	Transformer Construction.....	16
8.6	Transformer Spreadsheets.....	17
9	Performance Data	20
9.1	Regulation in DVD Recording Mode	20
9.2	Efficiency.....	20
9.3	Standby Input Power	21
9.4	Peak Load Margin	21
10	Thermal Performance	22
11	Control Loop Measurements.....	23
11.1	110 VAC Maximum Continuous Load	23
11.2	230 VAC Maximum Continuous Load	23
12	Waveforms.....	24
12.1	Drain Voltage Normal Operation	24
12.2	Output Voltage Start-up Profile	24
12.3	Drain Voltage Start-up Profile.....	26
13	Conducted EMI	27
13.1	230V High Line EMI	27
13.2	110V Low Line EMI	28
14	Revision History.....	29



Important Note:

Although this board is designed to satisfy safety isolation requirements, the engineering prototype has not been agency approved. Therefore, all testing should be performed using an isolation transformer to provide the AC input to the prototype board.

Design Reports contain a power supply design specification, schematic, bill of materials, and transformer documentation. Performance data and typical operation characteristics are included. Typically only a single prototype has been built.



1 Introduction

This document is an engineering report describing the PSU design using TOP246Y. This design adopts a one transformer solution instead of two transformers as originally used in the application, eliminates one X-cap, several Y-caps, a linear regulator and several heatsinks, and uses a smaller transformer. The new design meets EMI and peak power with good margin. The use of a smaller transformer is made possible by TOPSwitch-GX's high switching frequency with good switching performance, and the low EMI with a low-cost filter is made possible because of TOPSwitch-GX's frequency jitter and E-Shield™ transformer winding techniques.

EcoSmart™ features allow low consumption during lower power standby mode.

This document contains the power supply specifications, schematic, Bill of materials, transformer documentation, printed circuit layout, and performance data.

2 Photograph



Figure 1 – Circuit Board Photograph.



3 Power Supply Specification

The load currents below are actual measurements of the DVD/R unit. The capability of the PSU design is higher than the measured consumption of the unit.

Description	Symbol	Min	Typ	Max	Units	Comment
Input Voltage	V_{IN}	90		265	VAC	2 Wires System
Frequency	f_{LINE}	47	50/60	64	Hz	
Output Voltage 1	V_{OUT1}	3.135	3.3	3.465	V	20 MHz Bandwidth for all the outputs
Output Ripple Voltage 1	$V_{RIPPLE1}$		150		mV	
Output Current 1	I_{OUT1}		1.51		A	
Output Voltage 2	V_{OUT2}	4.75	5.0	5.25	V	
Output Ripple Voltage 2	$V_{RIPPLE2}$		150		mV	
Output Current 2	I_{OUT2}		1.40		A	
Output Voltage 3	V_{OUT3}	10.5	12	13.5	V	
Output Ripple Voltage 3	$V_{RIPPLE3}$		240		mV	
Output Current 3	I_{OUT3}		0.72	2.75	A	
Output Voltage 4 (FL)	V_{OUT4}	2.5	3.0	3.5	V	
Output Ripple Voltage 4	$V_{RIPPLE4}$				mV	
Output Current 4	I_{OUT4}		0.1		A	
Output Voltage 5	V_{OUT5}	-19.8	-22.0	-24.2	V	
Output Ripple Voltage 5	$V_{RIPPLE5}$		280		mV	
Output Current 5	I_{OUT5}		0.004		A	
Total Output Power						
Continuous Output Power	P_{OUT}		21		W	Actual load measurement
Peak Output Power	$P_{OUT PEAK}$		45		W	
Efficiency	η	74			%	Measured at P_{OUT} (21W), 25 °C
Environmental						
Conducted EMI		Meets CISPR22B / EN55022B				
Safety		Designed to meet IEC950, UL1950 Class II				
Ambient Temperature	T_{AMB}		25		°C	Free convection, sea level

Note: When the maximum input power happens, only 12V output shows a significantly higher peak power. All other outputs are specified at average output current at DVD drive recorder mode.



4 Schematic

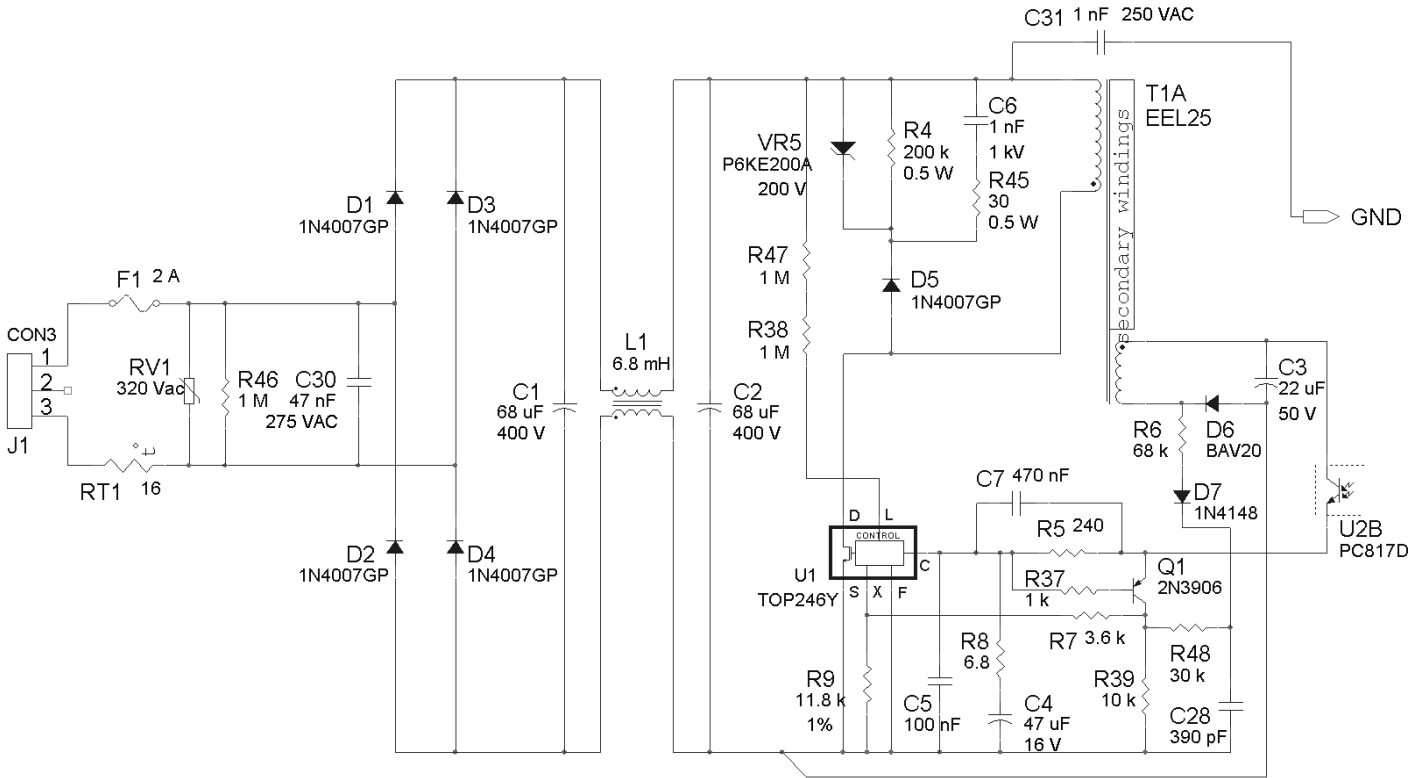

Figure 2 – Schematic (Primary side).



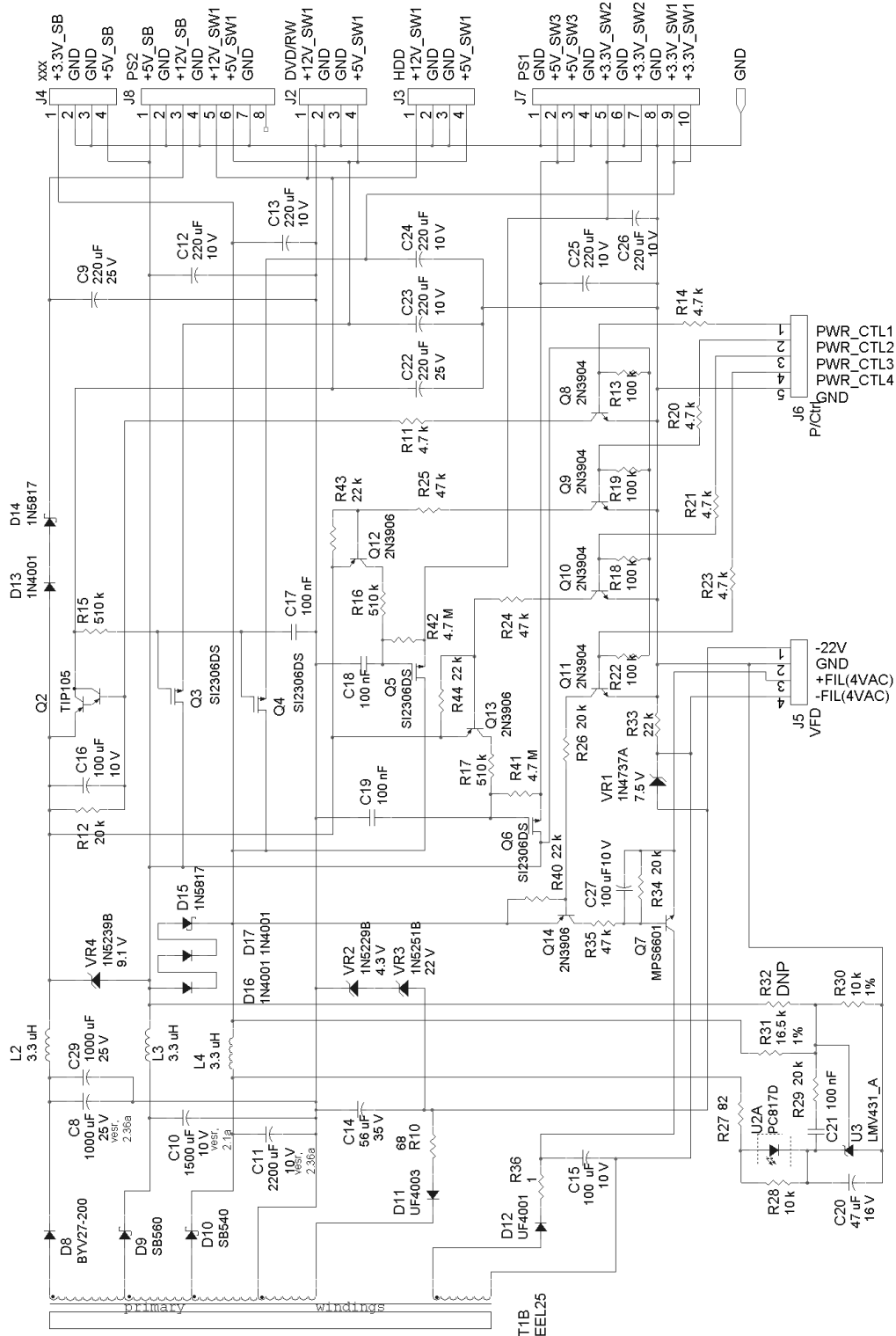

Figure 3 –Schematic (Secondary side)



5 Circuit Description

The schematic in Figure 2 shows an off-line flyback converter using the TOP246Y. The circuit is designed for 90 VAC to 265 VAC input. The schematic in Figure 3 shows the secondary circuit to supply the power rails to the DVD circuits, with associated power rail control for low power modes.

5.1 Input EMI Filtering

Capacitors C1, C2, X-capacitor C30, and common-mode choke L1 act as an input filter to reduce common mode and differential mode EMI. The X capacitor and Common Mode choke required in this design to achieve low EMI is very small and low cost, because of the frequency 'jitter' (modulation) feature of the TOPSwitch-GX.

5.2 TOPSwitch Primary

The AC line voltage is rectified and filtered to generate a high voltage DC bus via D1-4 and C1 and C2. Diode D5, C6, and R4, and R45 clamp leakage spikes generated when the MOSFET in U1 switches off. D5 is a glass-passivated normal recovery rectifier. The slow, controlled recovery time of D5 allows energy stored in C6 to be recycled back to the high voltage bus, significantly increasing efficiency. A normal (non-glass-passivated) 1N4007 should not be substituted for the glass-passivated device. C5 bypasses the U1 control pin. C4 has three functions. It provides the energy required by U1 during startup, sets the auto-restart frequency during fault conditions, and also acts to roll off the gain of U1 as a function of frequency. R8 adds a zero to the control loop to help stabilize the power supply control loop. Diode D6 and capacitor C3 provide rectified and filtered bias power for U1 and U2. Components Q1, D7, C7, C28 R5, R6, R7, R39, R48 provide a signal to the U1 X pin to allow aggressive frequency reduction at light load, reducing power consumption.

5.3 Outputs

The T1 output is rectified and filtered by Diodes D8-D12 and filtered by inductor/capacitor networks on most outputs. MOSFETs Q3, Q4 and Q5 are used to switch the low supply rails. Darlington device Q2 is used to switch the 12V rail. Level shifting transistors Q8-Q14 are used to drive the rail switch devices in response to logic signals PWR_CNTL1-4.

5.4 Output Feedback

Output feedback is used from a combination of the 5 V and the 3.3 V rails. Resistors R31 and R30 develop a feedback voltage, which is fed to the reference regulator U3. U3 drives optocoupler U2 through resistor R27 to provide feedback information to the U1 control pin. The optocoupler output also provides power to U1 during normal operating conditions. Capacitor C20 applies drive to the optocoupler during supply startup to reduce output voltage overshoot. Capacitor C21 and R29 provide frequency compensation for error amplifier U3.



5.5 Rev 2 to Rev3 changes

OV/UV resistor from L pin was added to provide additional protection, using the TOPSwitch-GX integrated under-voltage / over-voltage feature. The X-pin frequency reduction circuit was also modified for improved margin.

Add	RT1, RV1, R46, R38, R47, R37, R48, C28
Changes	Updated Gain/Phase plot
	C7 from 47nF to 470nF
	C21 from 10nF to 100nF
	R6 from 18k to 68k
	R7 from 16k to 3.6k
R27 from 470 to 82	
Delete	VR6



6 PCB Layout

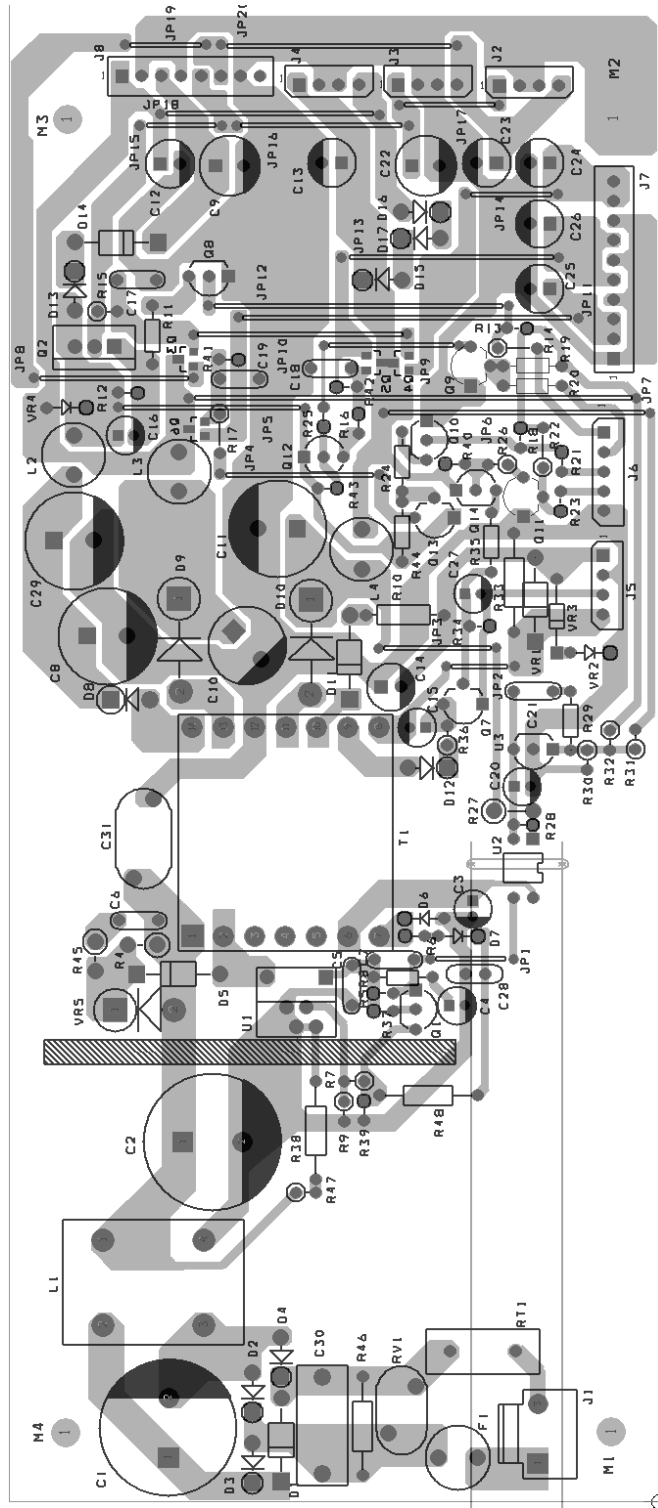

Figure 4 – Printed Circuit Layout

Note: R32 is not stuffed on the PCB.



7 Bill Of Materials

Item	Qua.	Value	Part Ref.	Description	Mfg Part Number	Mfg
1	2	68 uF	C1 C2	68 uF, 400 V, Electrolytic, Low ESR, 530 mOhm, (18 x 25)	KMX400VB68RM18X25LL	United Chemi-Con
2	1	22 uF	C3	22 uF, 50 V, Electrolytic, Very Low ESR, 340 mOhm, (5 x 11)	KZE50VB22RME11LL	United Chemi-Con
3	2	47 uF	C4 C20	47 uF, 16 V, General Purpose, (5 x 11)		Any
4	5	100 nF	C5 C17 C18 C19 C21	100 nF, 50 V, Ceramic, X7R	ECU-S1H104KBB	Panasonic
5	1	1 nF	C6	1 nF, 1 kV, Disc Ceramic	NCD102K1KVY5F	NIC Components Corp
6	1	470 nF	C7	470 nF, 50 V, Ceramic, X7R	ECU-S1H474KBB	Panasonic
7	2	1000 uF	C8 C29	1000 uF, 25 V, Electrolytic, Very Low ESR, 21 mOhm, (12.5 x 20)	KZE25VB102MK20LL	United Chemi-Con
8	2	220 uF	C9 C22	220 uF, 25 V, Electrolytic, Low ESR, 120 mOhm, (8 x 12)	LXZ25VB221MH15LL	United Chemi-Con
9	1	1500 uF	C10	1500 uF, 10 V, Electrolytic, Very Low ESR, 22 mOhm, (10 x 25)	KZE10VB152MJ25LL	United Chemi-Con
10	1	2200 uF	C11	2200 uF, 10 V, Electrolytic, Very Low ESR, 21 mOhm, (12.5 x 20)	KZE10VB222MK20LL	United Chemi-Con
11	6	220 uF	C12 C13 C23 C24 C25 C26	220 uF, 10 V, Electrolytic, Low ESR, 250 mOhm, (6.3 x 11.5)	LXZ10VB221MF11LL	United Chemi-Con
12	1	56 uF	C14	56 uF, 35 V, Electrolytic, Low ESR, 250 mOhm, (6.3 x 11.5)	LXZ35VB56RMF11LL	United Chemi-Con
13	1	100 uF	C15	100 uF, 10 V, Electrolytic, Very Low ESR, 300 mOhm, (5 x 11)	KZE10VB101ME11LL	United Chemi-Con
14	2	100 uF	C16 C27	100 uF, 10 V, Electrolytic, Gen. Purpose, (5 x 11)	KME10VB101M5X11LL	United Chemi-Con
15	1	390 pF	C28	390 pF, 50 V, Ceramic, COG	ECU-S1H391JCA	Panasonic
16	1	47 nF	C30	47 nF, 275 VAC, Film, X2	B81130B1473M	Epcos
17	1	1 nF	C31	1 nF, Ceramic, Y1	440LD10	Vishay
18	5	1N4007GP	D1 D2 D3 D4 D5	1000 V, 1 A, Rectifier, Glass Passivated, 2 us, DO-41	1N4007GP	Vishay
19	1	BAV20	D6	200 V, 200 mA, Fast Switching, 50 ns, DO-35	BAV20	Vishay
20	1	1N4148	D7	75 V, 300 mA, Fast Switching, DO-35	1N4148	Vishay
21	1	BYV27-200	D8	200 V, 2 A, Ultrafast Recovery, 25 ns, SOD57	BYV27-200	Philips
22	1	SB560	D9	60 V, 5 A, Schottky, DO-201AD	SB560	Vishay
23	1	SB540	D10	40 V, 5 A, Schottky, DO-201AD	SB540	Vishay
24	1	UF4003	D11	200 V, 1 A, Ultrafast Recovery, 50 ns, DO-41	UF4003	Vishay
25	1	UF4001	D12	50 V, 1 A, Ultrafast Recovery, 50 ns, DO-41	UF4001	Vishay
26	3	1N4001	D13 D16 D17	50 V, 1 A, Rectifier, DO-41	1N4001	Vishay
27	2	1N5817	D14 D15	20 V, 1 A, Schottky, DO-41	1N5817	Vishay
28	1	2 A	F1	2 A, 250V, Slow, TR5	3.721.200.041	Wickman
29	1	CON3	J1	3 Position (1 x 3) header, 0.156 pitch, Vertical	26-48-1031	Molex
30	4	DVD/RW	J2 J3 J4 J5	4 Position (1 x 4) header, 0.1 pitch, Vertical	22-28-4049	Molex
31	1	P/Ctrl	J6	5 Position (1 x 5) header, 0.1 pitch, Vertical	22-28-4050	Molex
32	1	PS1	J7	10 Position (1 x 10) header, 0.1 pitch, Vertical	22-28-4100	Molex
33	1	PS2	J8	8 Position (1 x 8) header, 0.1 pitch, Vertical	22-28-4080	Molex
34	1	6.8 mH	L1	6.8 mH, 0.8 A, Common Mode Choke	ELF15N008	Panasonic
35	3	3.3 uH	L2 L3 L4	3.3 uH, 2.66 A	822LY-3R3M	Toko
36	4	Mounting holes	M1 M2 M3 M4	PCB Terminal Hole, 18 AWG	N/A	N/A
37	4	2N3906	Q1 Q12 Q13 Q14	PNP, Small Signal BJT, 40 V, 0.2 A, TO-92	2N3906	Fairchild
38	1	TIP105	Q2	PNP Darlington, Power BJT, 60 V, 8 A, TO-220	TIP105	Fairchild
39	4	SI2306DS	Q3 Q4 Q5 Q6	20 V, N-Channel, SOT 23	SI2306ADS	Vishay
40	1	MPS6601	Q7	NPN, Small Signal BJT, TO-92	MPS6601	On Semiconductor
41	4	2N3904	Q8 Q9 Q10 Q11	NPN, Small Signal BJT, 40 V, 0.2 A, TO-92	2N3904	Fairchild
42	1	200 k	R4	200 k, 5%, 1/2 W, Carbon Film	CFR-50JB-200K	Yageo



43	1	240	R5	240 R, 5%, 1/8 W, Carbon Film	CFR-12JB-240R	Yageo
44	1	68 k	R6	68 k, 5%, 1/8 W, Carbon Film	CFR-12JB-68K	Yageo
45	1	3.6 k	R7	3.6 k, 5%, 1/4 W, Carbon Film	CFR-25JB-3K6	Yageo
46	1	6.8	R8	6.8 R, 5%, 1/8 W, Carbon Film	CFR-12JB-6R8	Yageo
47	1	11.8 k	R9	11.8 k, 1%, 1/4 W, Metal Film	MFR-25FBF-11K8	Yageo
48	1	68	R10	68 R, 5%, 1/4 W, Carbon Film	CFR-25JB-68R	Yageo
49	5	4.7 k	R11 R14 R20 R21 R23	4.7 k, 5%, 1/8 W, Carbon Film	CFR-12JB-4K7	Yageo
50	7	20 k	R12 R13 R18 R22 R26 R29 R34	20 k, 5%, 1/8 W, Carbon Film	CFR-12JB-20K	Yageo
51	2	510 k	R15 R17	510 k, 5%, 1/4 W, Carbon Film	CFR-25JB-510K	Yageo
52	1	510 k	R16	510 k, 5%, 1/8 W, Carbon Film	CFR-12JB-510K	Yageo
53	1	100 k	R19	100 k, 5%, 1/8 W, Carbon Film	CFR-12JB-100K	Yageo
54	3	47 k	R24 R25 R35	47 k, 5%, 1/8 W, Carbon Film	CFR-12JB-47K	Yageo
55	1	82	R27	82 R, 5%, 1/4 W, Carbon Film	CFR-25JB-82R	Yageo
56	2	10 k	R28 R39	10 k, 5%, 1/8 W, Carbon Film	CFR-12JB-10K	Yageo
57	1	10 k	R30	10 k, 1%, 1/4 W, Metal Film	MFR-25FBF-10K0	Yageo
58	1	16.5 k	R31	16.5 k, 1%, 1/4 W, Metal Film	MFR-25FBF-16K5	Yageo
59	1	37.4 k	R32	37.4 k, 1%, 1/4 W, Metal Film	MFR-25FBF-37K4	Yageo
60	1	22 k	R33	22 k, 5%, 1/4 W, Carbon Film	CFR-25JB-22K	Yageo
61	1	1	R36	1 R, 5%, 1/4 W, Carbon Film	CFR-25JB-1R0	Yageo
62	1	1 k	R37	1 k, 5%, 1/4 W, Carbon Film	CFR-25JB-1K0	Yageo
63	3	1 M	R38 R46 R47	1 M, 5%, 1/4 W, Carbon Film	CFR-25JB-1M0	Yageo
64	3	22 k	R40 R43 R44	22 k, 5%, 1/8 W, Carbon Film	CFR-12JB-22K	Yageo
65	2	4.7 M	R41 R42	4.7 M, 5%, 1/8 W, Carbon Film	CFR-12JB-4M7	Yageo
66	1	30	R45	30 R, 5%, 1/2 W, Carbon Film	CFR-50JB-30R	Yageo
67	1	30 k	R48	30 k, 5%, 1/4 W, Carbon Film	CFR-25JB-30K	Yageo
68	1	16	RT1	NTC Thermistor, 16 Ohms, 1.7 A	CL180	Thermometrics
69	1	320 Vac	RV1	320 V, 26 J, 7 mm, RADIAL	V320LA7	Littlefuse
70	1	EEL25	T1	Custom		
71	1	TOP246Y	U1	TOPSwitch-GX, TOP246Y, TO220-7C	TOP246Y	Power Integrations
72	1	PC817D	U2	Opto coupler, 35 V, CTR 80-160%, 4-DIP	ISP817A, PC817X1	Isocom, Sharp
73	1	LMV431_A	U3	1.24V Shunt Reg IC	LMV431ACZ	National Semiconductor
74	1	1N4737A	VR1	7.5 V, 5%, 1 W, DO-41	1N4737A	Diodes Inc.
75	1	1N5229B	VR2	4.3 V, 5%, 500 mW, DO-35	1N5229B	Microsemi
76	1	1N5251B	VR3	22 V, 5%, 500 mW, DO-35	1N5251B	Microsemi
77	1	1N5239B	VR4	9.1 V, 5%, 500 mW, DO-35	1N5239B	Microsemi
78	1	P6KE200A	VR5	200 V, 5 W, 5%, DO204AC (DO-15)	P6KE200A	Vishay
79	1		H1	Heatsink		Any

Note: Item 79, H1 heatsink, is a plain sheet metal heatsink 11x24x0.5 mm with a solderable tab at one end. It is soldered onto cathode of D9, which is an axial diode. Material used on the prototype was copper but plated mild steel can be used.



8 Transformer Specification

8.1 Electrical Diagram

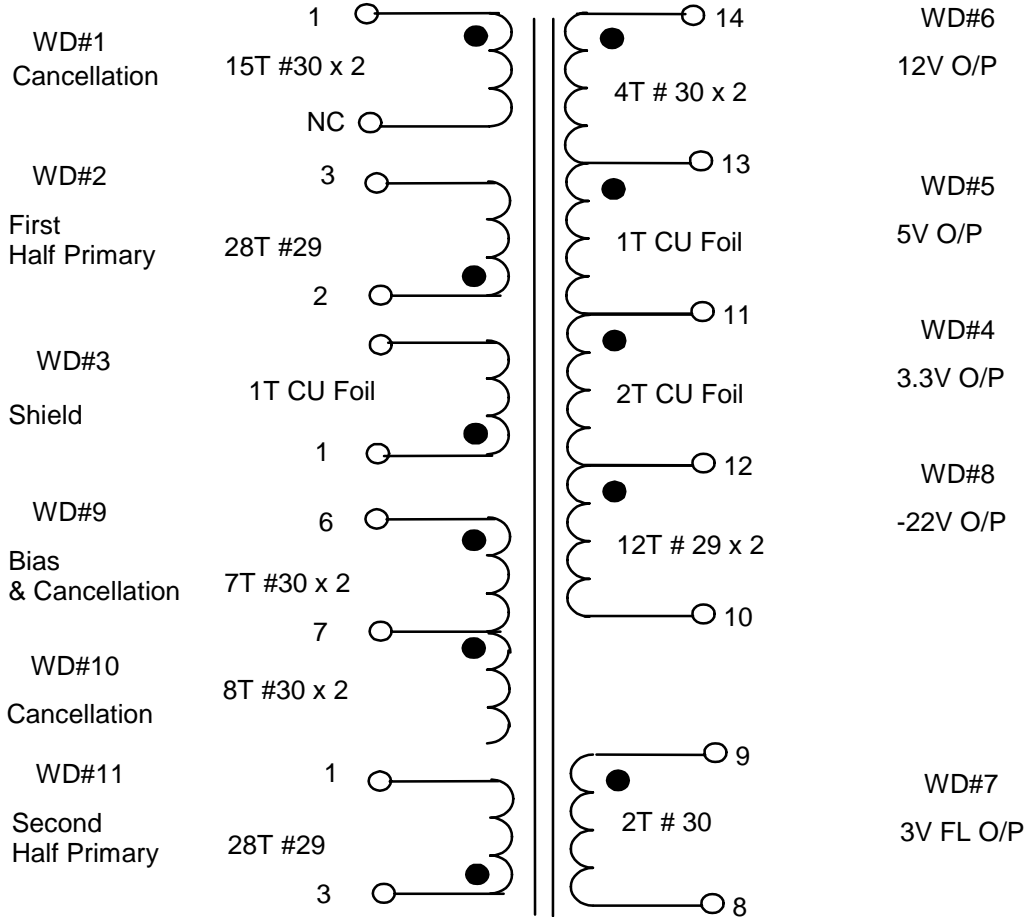

Figure 5 –Transformer Electrical Diagram

8.2 Electrical Specifications

Electrical Strength	1 second, 60 Hz, from Pins 1 - 7 to Pins 8 -14	3000 VAC
Primary Inductance	Pins 1-2, all other windings open, measured at 132 kHz, 0.4 VRMS	422 uH, -10/+10%
Resonant Frequency	Pins 1-2, all other windings open	1M kHz (Min.)
Primary Leakage Inductance	Pins 1-2, with Pins 7-14 shorted, measured at 132 kHz, 0.4 VRMS	10 uH (Max.)



8.3 Materials

Item	Description
[1]	Core: PC40EEL25, TDK or equivalent Gapped for AL of 134 nH/T ²
[2]	Bobbin: EEL25, Horizontal 14 pins
[3]	Magnet Wire: #30 AWG
[4]	Magnet Wire: #29 AWG
[5]	Magnet Wire: #28 AWG
[6]	WD#3, CU Foil: 2mil x 10mm wide x 50 mm long
[7]	WD#4&5 CU Foil: 2mil x 9mm wide x 134 mm long
[8]	Tape: Margin 6 mm
[9]	Tape: 3M 1298 Polyester Film, 10.6mm wide
[10]	Tape: 3M 1298 Polyester Film, 22.4mm wide

8.4 Transformer Build Diagram

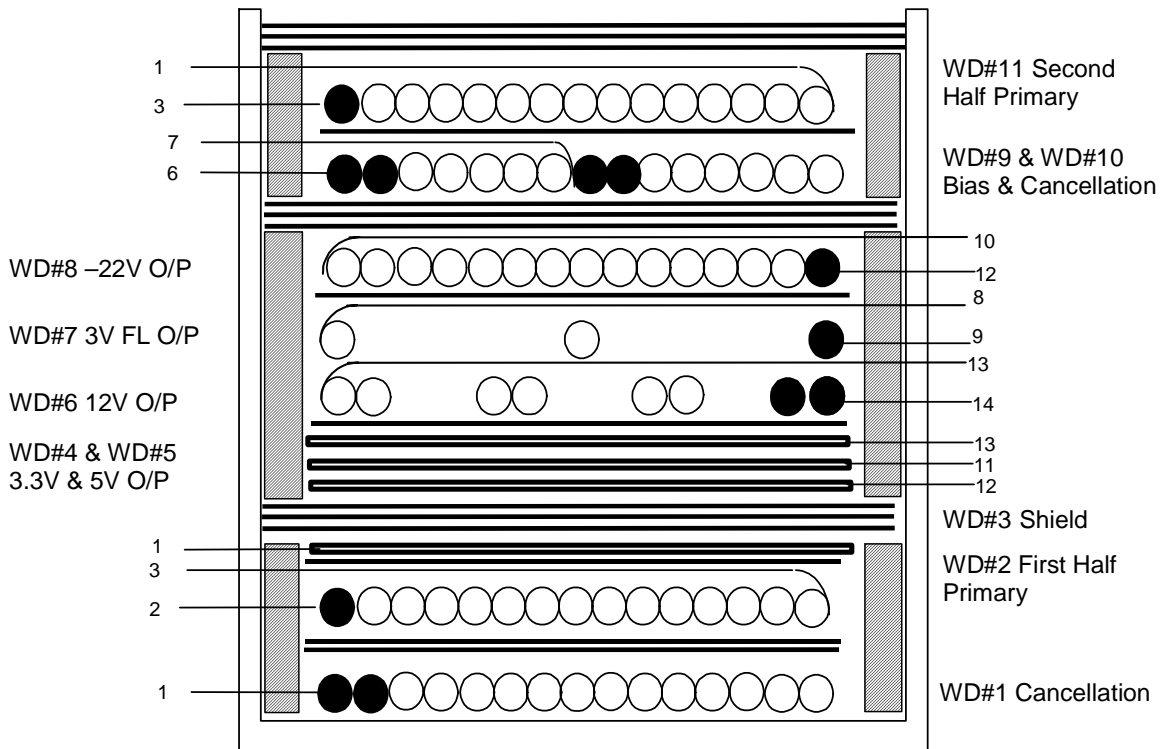

Figure 6 – Transformer Build Diagram.



8.4.1 WD#3 Copper Foil build diagram:

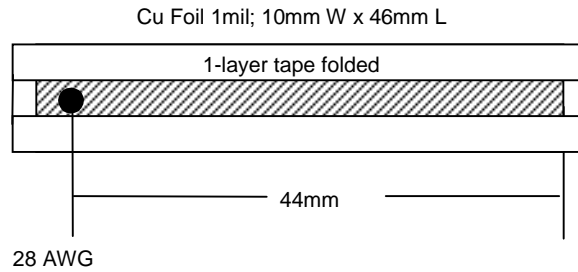

Figure 7 – Copper Foil Build Diagram.

8.4.2 WDG#4 & #5 Copper Foil build diagram:

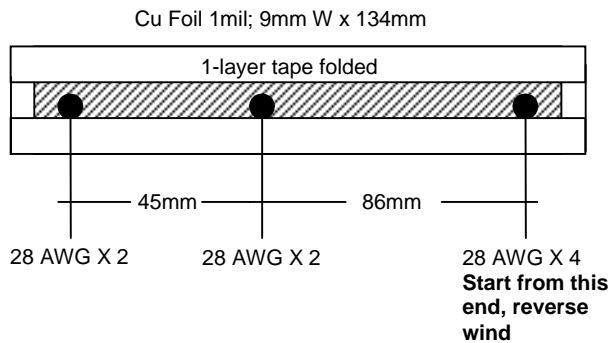

Figure 8 – Copper Foil Build Diagram



8.5 Transformer Construction

Bobbin Preparation	Pin1 side of the bobbin orients to the left hand side.
Margin Tape	Wind item [8] at the each pin side of the bobbin to match the height of the first half primary windings.
WD#1 Cancellation	Start on Pin 1, wind 15 turns bifilar of item [3] from left to right. Wind with tight tension. Cut the wires after finishing 15 th turns. Overall, total 15 turns winding should be well fit the entire length of the bobbin.
Insulation	2 Layers of tape [9] for insulation
WD#2 Fist Half Primary	Start on pin 2, wind 28 turns of item [4] from left to right. After finishing the 28 th turns, All the wires should be well fit the entire length of the bobbin. Bring the lead back to the left side and finish it on Pin 3.
Insulation	1 Layer of tape [9] for insulation.
WD #3 Shield	Start at Pin 1, wind 1turns of item [6]. Clock-wise wind with tension. Apply a small piece tape to secure the end of the foil.
Insulation	3 Layers of tape [10] for insulation.
Margin Tape	Wind item [8] at the each pin side of the bobbin to match the height of the secondary windings.
WD #4 & WD #5	Start at pin 12, anti-clock-wise wind 2 turns of item [7]. Wind with tight. Finish the middle termination to pin 11, then continue to wind the last turn and finish it on pin 13. Apply a piece of tape to secure the end of the foil
Insulation	1 Layer of tape [9] for insulation.
WD #6	Start at pin 14, wind 4 turns bifilar of item [3] from right to left. Wind uniformly, in a single layer across entire bobbin evenly. Bring the wire back and finish on pin 13.
WD #7	Start at pin 9, wind 2 turns of item [3] from right to left. Wind between the wire gaps of the previous winding, in a single layer across entire bobbin evenly. Bring the wire back and finish on pin 8.
Insulation	1 Layer of tape [9] for insulation.
WD #8	Start at pin 12, wind 12 turns bifilar of item [4] from right to left. Wind uniformly, in a single layer across entire bobbin evenly. Bring the wire back and finish on pin 10.
Insulation	3 Layers of tape [10] for insulation.
WD #9 & WD10	Start on Pin 6, wind 7 turns bifilar of item [3] from left to right. Wind with tight tension. After finishing 7 th turn, bring the wire back and finish it on Pin 7. Start from the Pin 7, rout the same wires to the ending position of the previous winding, continuous to wind another 8 turns, cut the wires after finishing 8 th turns. Overall, total 15 turns winding should be well fit the entire length of the bobbin.
Insulation	1Layer of tape [9] for insulation.
WD #11	Start on pin 3, wind 28 turns of item [4] from left to right. After finishing the 28 th turns, All the wires should be well fit the entire length of the bobbin. Bring the lead back to the left side and finish it on Pin 1.
Insulation	3 Layers of tape [10] for insulation.
Finish	Grind the core to get 422uH. Secure the core with tape.



8.6 Transformer Spreadsheets

ACDC_TOPSwitchGX_032204; Rev.1.9; Copyright Power Integrations Inc. 2004	INPUT	INFO	INFO	OUTPUT	OUTPUT	UNIT	TOP_GX_FX_032204.xls: TOPSwitch-GX/FX Continuous/Discontinuous Flyback Transformer Design Spreadsheet
ENTER APPLICATION VARIABLES							Customer
VACMIN	90					Volts	Minimum AC Input Voltage
VACMAX	265					Volts	Maximum AC Input Voltage
fL	50					Hertz	AC Mains Frequency
VO	5					Volts	Output Voltage
PO	45					Watts	Output Power
η	0.73						Efficiency Estimate
Z	0.5						Loss Allocation Factor
VB	15					Volts	Bias Voltage
tC	3					mSeconds	Bridge Rectifier Conduction Time Estimate
CIN	136					uFarads	Input Filter Capacitor
ENTER TOPSWITCH-GX VARIABLES							
TOP-GX		TOP246				Universal	115 Doubled/230V
Chosen Device		TOP246	TOP246	Power Out	Power Out	90W	125W
KI	0.7						External Ilimit reduction factor (KI=1.0 for default ILIMIT. KI <1.0 for lower ILIMIT)
ILIMITMIN				1.701	1.701	Amps	Use 1% resistor in setting external ILIMIT
ILIMITMAX				2.079	2.079	Amps	Use 1% resistor in setting external ILIMIT
Frequency (F)=132kHz. (H)=66kHz	F						Full (F) frequency option - 132kHz
fS				132000	132000	Hertz	TOPSwitch-GX Switching Frequency: Choose between 132 kHz and 66 kHz
fSmin				124000	124000	Hertz	TOPSwitch-GX Minimum Switching Frequency
fSmax				140000	140000	Hertz	TOPSwitch-GX Maximum Switching Frequency
VOR	103					Volts	Reflected Output Voltage
VDS	10					Volts	TOPSwitch on-state Drain to Source Voltage
VD	0.5					Volts	Output Winding Diode Forward Voltage Drop
VDB	0.7					Volts	Bias Winding Diode Forward Voltage Drop
KP	0.55						Ripple to Peak Current Ratio (0.4 < KRP < 1.0 : 1.0 < KDP < 6.0)
ENTER TRANSFORMER CORE/CONSTRUCTION VARIABLES							
Core Type	eel25						
Core		EEL25	EEL25			P/N:	PC40EE25.4/32/6.4-Z
Bobbin		EEL25 BOBBIN	EEL25 BOBBIN			P/N:	*
AE				0.404	0.404	cm^2	Core Effective Cross Sectional Area
LE				7.34	7.34	cm	Core Effective Path Length
AL				1420	1420	nH/T^2	Ungapped Core Effective Inductance
BW				22.3	22.3	mm	Bobbin Physical Winding Width
M	6					mm	Safety Margin Width (Half the Primary to Secondary Creepage Distance)
L	2						Number of Primary Layers
NS	3						Number of Secondary Turns
DC INPUT VOLTAGE PARAMETERS							
VMIN				99	99	Volts	Minimum DC Input Voltage



VMAX				375	375	Volts	Maximum DC Input Voltage
CURRENT WAVEFORM SHAPE PARAMETERS							
DMAX				0.54	0.54		Maximum Duty Cycle
IAVG				0.62	0.62	Amps	Average Primary Current
IP				1.60	1.60	Amps	Peak Primary Current
IR				0.88	0.88	Amps	Primary Ripple Current
IRMS				0.87	0.87	Amps	Primary RMS Current
TRANSFORMER PRIMARY DESIGN PARAMETERS							
LP				422	422	uHenries	Primary Inductance
NP				56	56		Primary Winding Number of Turns
NB				9	9		Bias Winding Number of Turns
ALG				134	134	nH/T^2	Gapped Core Effective Inductance
BM				2972	2972	Gauss	Maximum Flux Density at PO, VMIN (BM<3000)
BP				3864	3864	Gauss	Peak Flux Density (BP<4200)
BAC				817	817	Gauss	AC Flux Density for Core Loss Curves (0.5 X Peak to Peak)
ur				2053	2053		Relative Permeability of Ungapped Core
LG				0.34	0.34	mm	Gap Length (Lg > 0.1 mm)
BWE				20.6	20.6	mm	Effective Bobbin Width
OD				0.37	0.37	mm	Maximum Primary Wire Diameter including insulation
INS				0.06	0.06	mm	Estimated Total Insulation Thickness (= 2 * film thickness)
DIA				0.31	0.31	mm	Bare conductor diameter
AWG				29	29	AWG	Primary Wire Gauge (Rounded to next smaller standard AWG value)
CM				128	128	Cmils	Bare conductor effective area in circular mils
CMA		Warning	Warning	147	147	Cmils/Amp	!!!!!!!!! INCREASE CMA>200 (increase L(primary layers),decrease NS,larger Core)
TRANSFORMER SECONDARY DESIGN PARAMETERS (SINGLE OUTPUT / SINGLE OUTPUT EQUIVALENT)							
Lumped parameters							
ISP				29.94	29.94	Amps	Peak Secondary Current
ISRMS				15.14	15.14	Amps	Secondary RMS Current
IO				9.00	9.00	Amps	Power Supply Output Current
IRIPPLE				12.18	12.18	Amps	Output Capacitor RMS Ripple Current
CMS				3028	3028	Cmils	Secondary Bare Conductor minimum circular mils
AWGS				15	15	AWG	Secondary Wire Gauge (Rounded up to next larger standard AWG value)
DIAS				1.45	1.45	mm	Secondary Minimum Bare Conductor Diameter
ODS				3.43	3.43	mm	Secondary Maximum Outside Diameter for Triple Insulated Wire
INSS				0.99	0.99	mm	Maximum Secondary Insulation Wall Thickness
VOLTAGE STRESS PARAMETERS							
VDRAIN				611	611	Volts	Maximum Drain Voltage Estimate (Includes Effect of Leakage Inductance)
PIVS				25	25	Volts	Output Rectifier Maximum Peak Inverse Voltage
PIVB				72	72	Volts	Bias Rectifier Maximum Peak Inverse Voltage
TRANSFORMER SECONDARY DESIGN PARAMETERS (MULTIPLE OUTPUTS)							
1st output							
VO1	3.3					Volts	Output Voltage
IO1	1.500					Amps	Output DC Current
PO1				4.95	4.95	Watts	Output Power



VD1	0.5					Volts	Output Diode Forward Voltage Drop
NS1				2.07	2.07		Output Winding Number of Turns
ISRMS1				2.524	2.524	Amps	Output Winding RMS Current
IRIPPLE1				2.03	2.03	Amps	Output Capacitor RMS Ripple Current
PIVS1				17	17	Volts	Output Rectifier Maximum Peak Inverse Voltage
CMS1				505	505	Cmils	Output Winding Bare Conductor minimum circular mils
AWGS1				23	23	AWG	Wire Gauge (Rounded up to next larger standard AWG value)
DIAS1				0.58	0.58	mm	Minimum Bare Conductor Diameter
ODS1				4.97	4.97	mm	Maximum Outside Diameter for Triple Insulated Wire
2nd output							
VO2	12.0					Volts	Output Voltage
IO2	0.700					Amps	Output DC Current
PO2				8.40	8.40	Watts	Output Power
VD2	0.7					Volts	Output Diode Forward Voltage Drop
NS2				6.93	6.93		Output Winding Number of Turns
ISRMS2				1.178	1.178	Amps	Output Winding RMS Current
IRIPPLE2				0.95	0.95	Amps	Output Capacitor RMS Ripple Current
PIVS2				58	58	Volts	Output Rectifier Maximum Peak Inverse Voltage
CMS2				236	236	Cmils	Output Winding Bare Conductor minimum circular mils
AWGS2				26	26	AWG	Wire Gauge (Rounded up to next larger standard AWG value)
DIAS2				0.41	0.41	mm	Minimum Bare Conductor Diameter
ODS2				1.49	1.49	mm	Maximum Outside Diameter for Triple Insulated Wire
3rd output							
VO3	22.0					Volts	Output Voltage
IO3	0.100					Amps	Output DC Current
PO3				2.20	2.20	Watts	Output Power
VD3	0.7					Volts	Output Diode Forward Voltage Drop
NS3				12.38	12.38		Output Winding Number of Turns
ISRMS3				0.168	0.168	Amps	Output Winding RMS Current
IRIPPLE3				0.14	0.14	Amps	Output Capacitor RMS Ripple Current
PIVS3				105	105	Volts	Output Rectifier Maximum Peak Inverse Voltage
CMS3				34	34	Cmils	Output Winding Bare Conductor minimum circular mils
AWGS3				34	34	AWG	Wire Gauge (Rounded up to next larger standard AWG value)
DIAS3				0.16	0.16	mm	Minimum Bare Conductor Diameter
ODS3				0.83	0.83	mm	Maximum Outside Diameter for Triple Insulated Wire



9 Performance Data

All measurements performed at room temperature, 60 Hz input frequency.

Some tests were performed using E-loads, some were performed in the actual DVD Recorder unit. The actual unit was only tested in HDD -> DVD-R recording mode, which shows the highest average and peak power draw. The DVD Recorder unit is a prototype which does not have the correct standby mode, nor the firmware to drive the control signals 1-4. So testing in the unit was done with signals 1-4 connected to 5Vsb to turn on all the switched outputs.

9.1 Regulation in DVD Recording Mode

A Fluke 87 in min/max recording mode was used to capture the min and max of each output. The test was done at room temperature, 90 Vac and 265 Vac input.

Output	90V	265V
	(V)	(V)
3.3 V _{SB}	3.261	3.263
3.3 V _{SW1}	3.206	3.207
3.3 V _{SW2}	3.221	3.222
5 V _{SB}	5.06	5.05
5 V _{SW1}	4.95	4.94
5V _{SW3}	5.03	5.02
12 V _{SB}	11.51	11.49
12 V _{SW1}	12.08	12.05
3 V _{FL}	2.55	2.49
- 22V	- 23.3	-22.6

9.2 Efficiency

E-loads were used for this measurement.

Output	Load		O/P Power
	Output (V)	Output (A)	(W)
3.3 V _{SW1}	3.22	1.53	4.927
5 V _{SW1}	4.95	1.39	6.881
12 V _{SW1}	12.01	0.87	10.45
3 V _{FL}	2.53	0.1	0.253
- 22V	- 23	0.004	0.092
Total output Power			22.60



Input Voltage	Efficiency
90Vac	76.4%
265Vac	78.2%

9.3 Standby Input Power

With E-load at 1W condition, 12VSB @ 2.5mA, 5VSB @20mA, Power Block 2 is loaded @340mW.

Input Voltage	Input Power
110 Vac	836mW
230 Vac	860mW

9.4 Peak Load Margin

A Flyback power supply has lowest peak power capability at minimum AC voltage. The DVD/R unit has very fluctuating power requirements, which are difficult to characterize. It draws maximum power when switching signal inputs or inserting the DVD tray. A good test for peak power margin is to see the minimum AC voltage that the unit can operate normally. The unit is powered up at, and operated at a reduced AC input voltage. The unit is cycled through different modes of operation – startup, eject, load, play, record, etc. The DVD/RW HDD functions normally.

Input voltage	Result
75Vac	PASS

75 Vac is a very good result and implies there is plenty of margin for peak power capability.



10 Thermal Performance

Test Condition: The DVD/RW HDD was set on the bench. The unit is recording (highest continuous load) during the test.

Temperature (°C)		
Item	90Vac	265Vac
	(°C)	
Ambient (°C)	25	
TOP246Y (U1)	67.7	56.2
5 V filter Cap (C10)	56.2	55.5
3.3 V Rectifier (D10)	75.1	74.3
5 V Rectifier (D9)	83.2	82.6

Note: H1 heatsink is attached to D9.



11 Control Loop Measurements

The power supply is loaded at 21W continuous load.

11.1 110 VAC Maximum Continuous Load

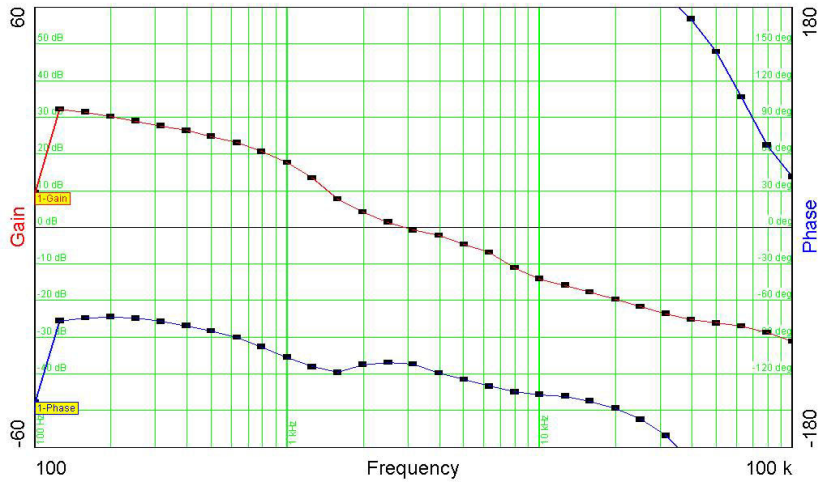

Figure 9 - Gain-Phase Plot, 110 VAC, 21W Steady State Load.
Vertical Scale: Gain = 10 dB/div, Phase = 30°/div.
Crossover Frequency = 3 kHz Phase Margin = 105°

11.2 230 VAC Maximum Continuous Load

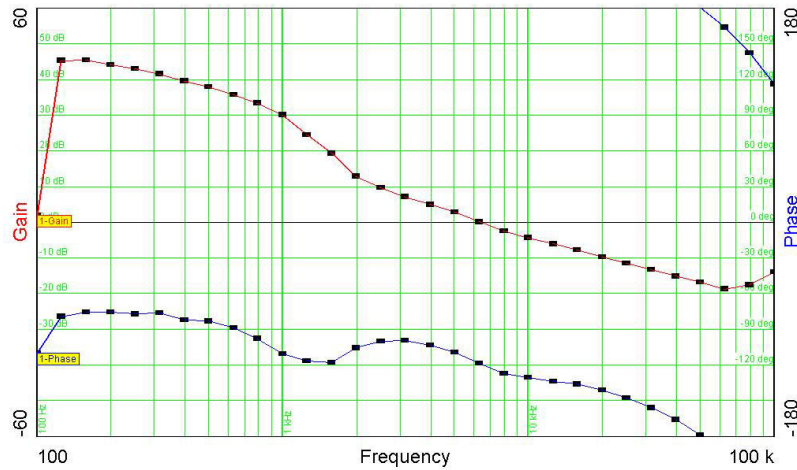

Figure 10 - Gain-Phase Plot, 230 VAC, 21W Steady State Load.
Vertical Scale: Gain = 10 dB/div, Phase = 30°/div.
Crossover Frequency = 6.5 kHz, Phase Margin = 60°



12 Waveforms

Waveforms were taken at 25°C

12.1 Drain Voltage Normal Operation

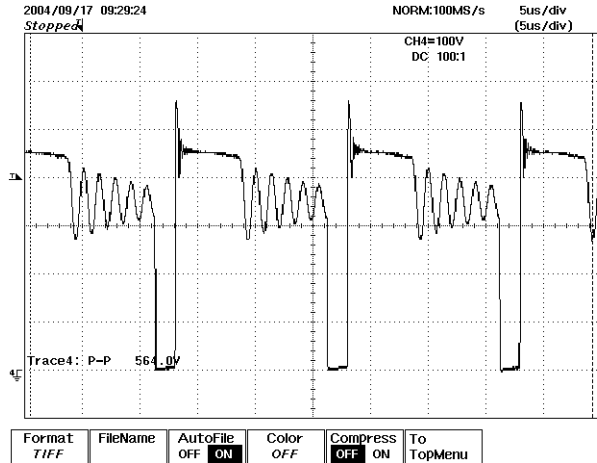

Figure 11 - 265 VAC, V_{DRAIN} , 100 V, 5 μ s / div

12.2 Output Voltage Start-up Profile

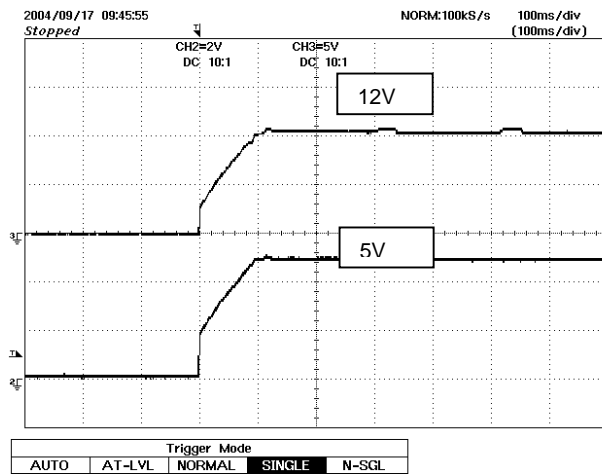

Figure 12 – Start-up Profile, 90 VAC
2V/div for 5V, 5V/div for 12V, 100 ms / div.

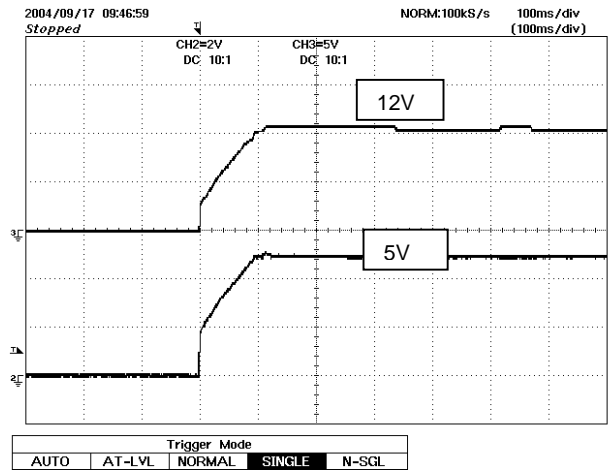

Figure 13 – Start-up Profile, 265 VAC
2V/div for 5V, 5V/div for 12V, 100 ms / div.



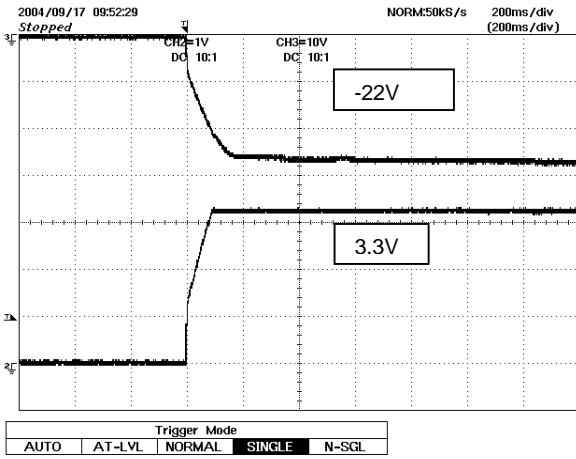

Figure 14 – Start-up Profile, 90 VAC
1V/div for 3.3V, 10V/div for -22V, 200 ms / div.

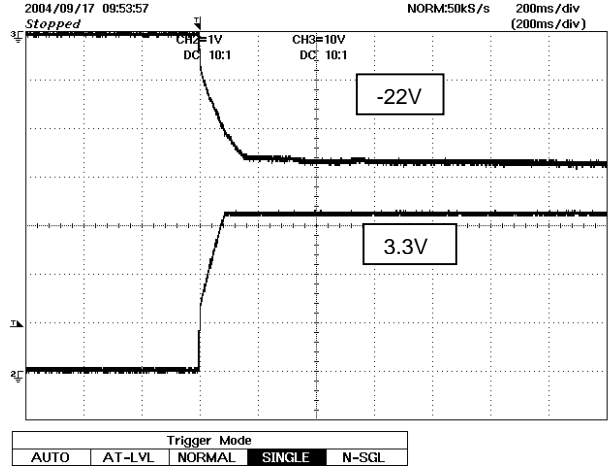

Figure 15 – Start-up Profile, 265 VAC
1V/div for 3.3V, 10V/div for -22V, 200 ms / div.

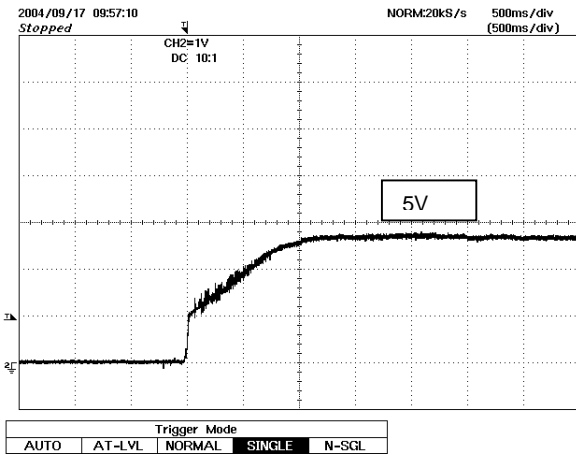

Figure 16 – Start-up Profile, 90 VAC
1V/div for 3V FL, 500 ms / div.

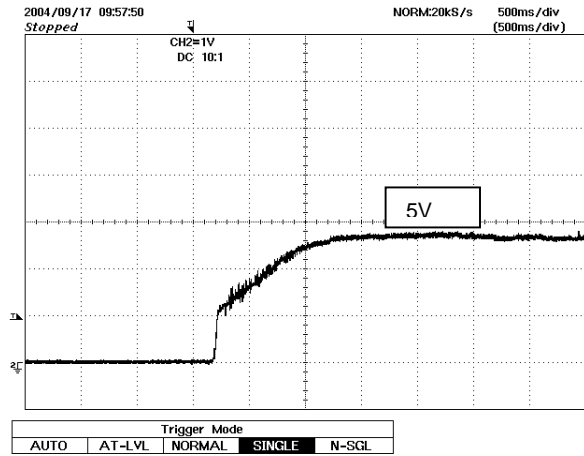

Figure 17 – Start-up Profile, 265 VAC
1V/div for 3V FL, 500 ms / div.



12.3 Drain Voltage Start-up Profile

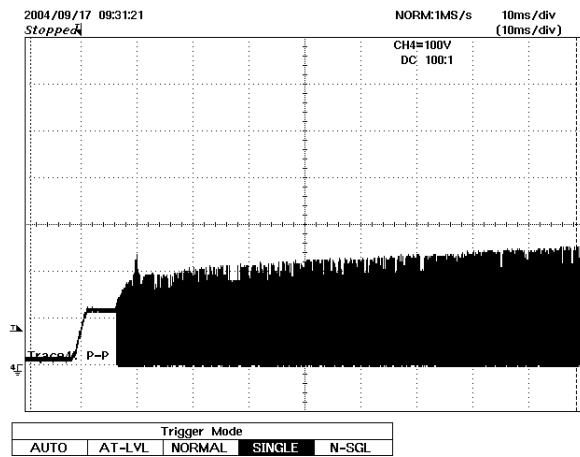

Figure 18 - 90 VAC Input. V_{DRAIN} , 100 V & 10 ms / div.

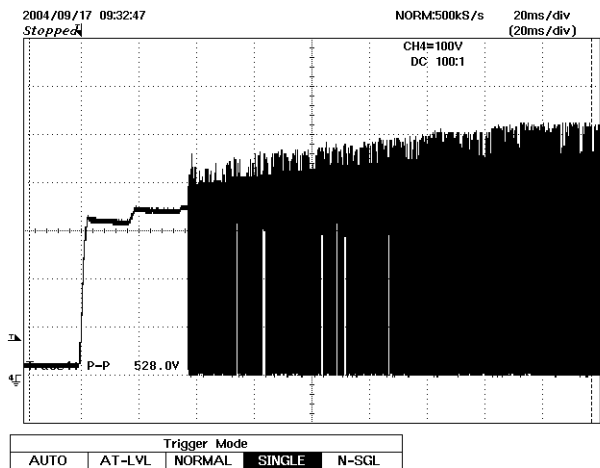

Figure 19 - 265 VAC Input. V_{DRAIN} , 100 V & 20 ms / div.



13 Conducted EMI

EMI was tested at room temperature and at 110 VAC & 230 VAC input. The TOP246Y PSU was installed in the DVD/RW HDD Recorder. The DVD/RW HDD was in recording mode during the test. Two conditions were tested. (1) Chassis connected to LISN ground (worst case), and (2) with no connection. Red line is QP, Blue line is AVG. EMI is low in spite of low-cost EMI filter because of TOP246Y built-in frequency jittering and E-Shield™ transformer winding technique.

13.1 230V High Line EMI

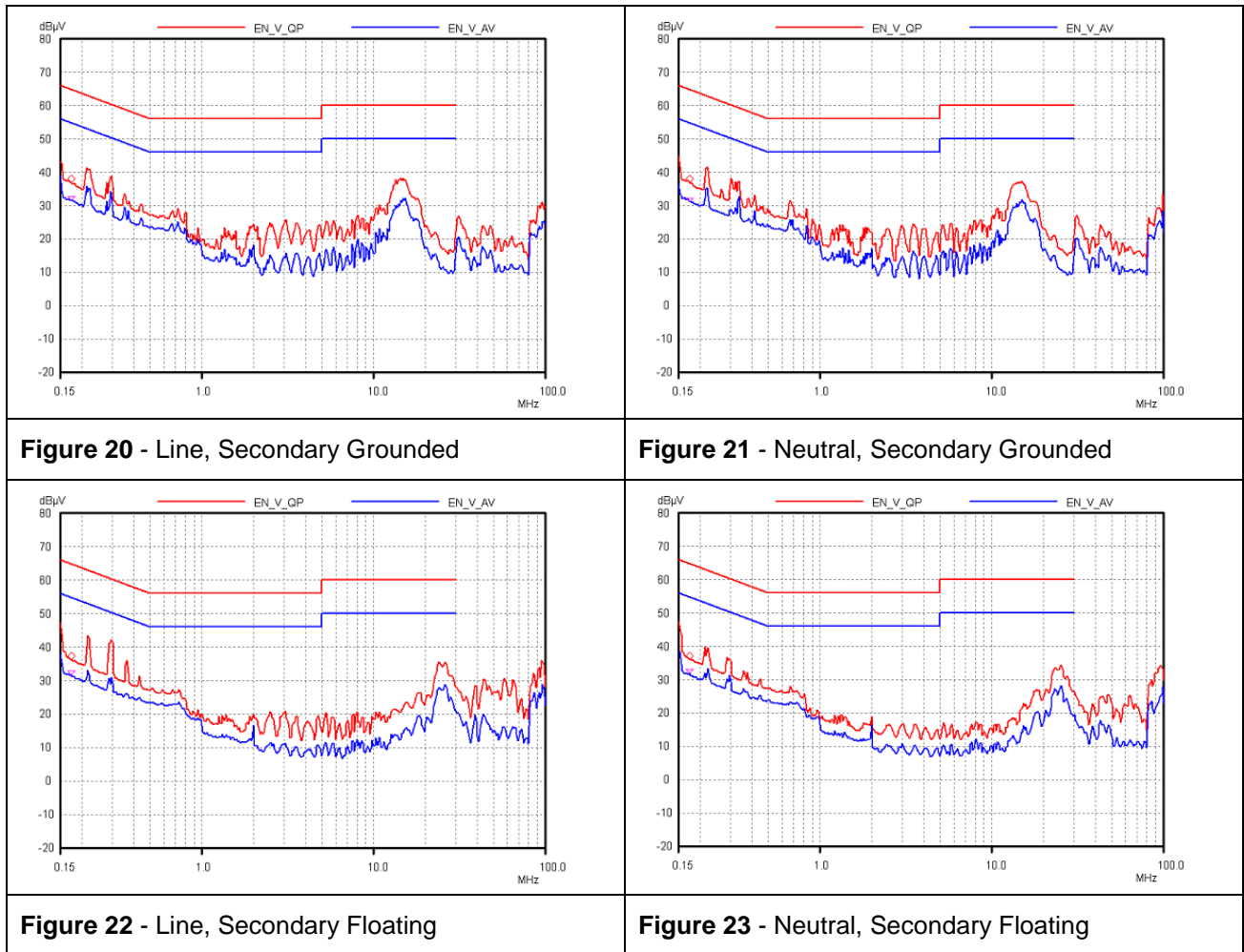

13.2 110V Low Line EMI

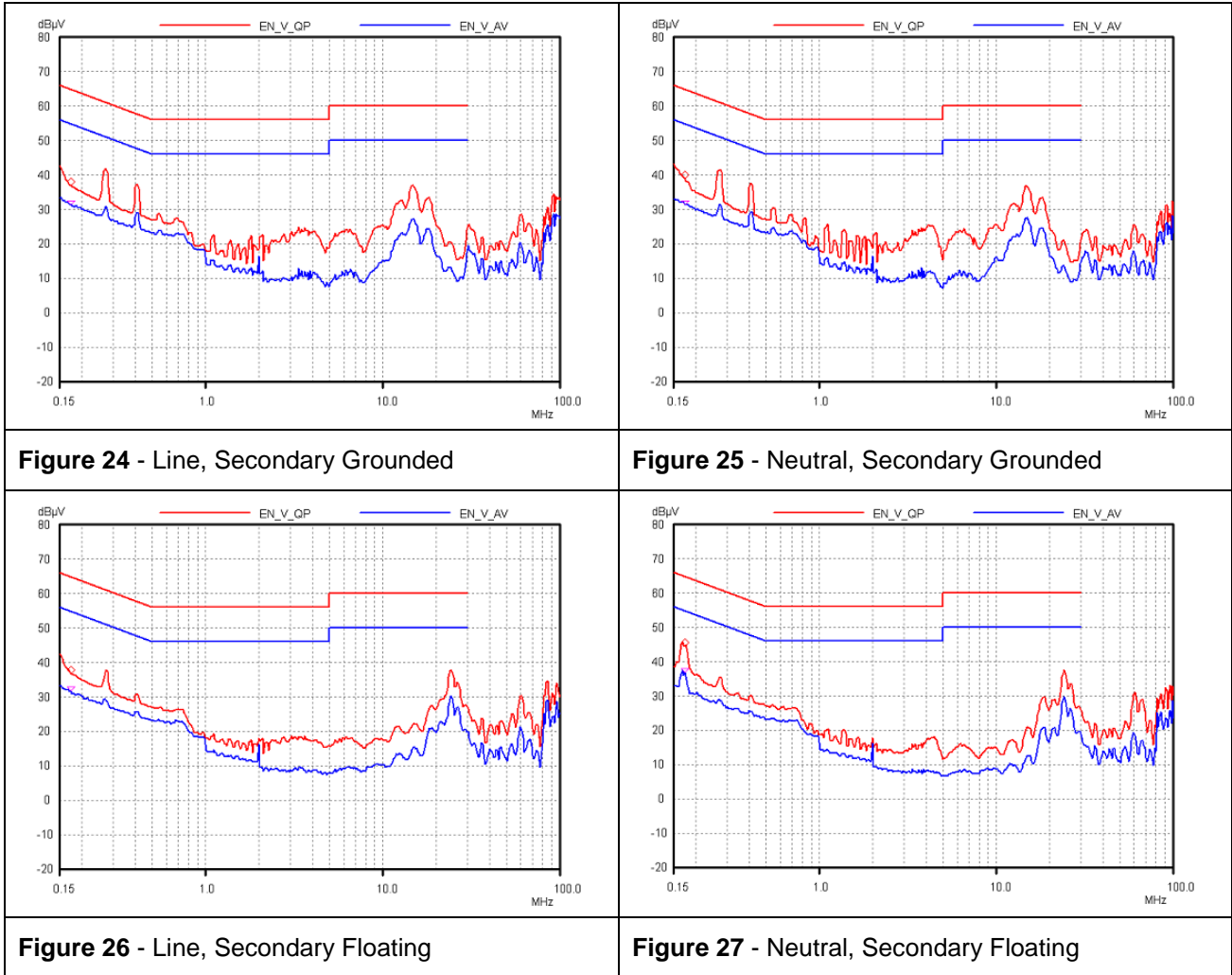

14 Revision History

Date	Author	Revision	Description & changes	Reviewed
Sept 21, 2004	DZ	1.0	Initial release	VC / AM
Sept 29, 2004	DZ	2.0	R1, R2, R3, R38 removed; R27 changed from 56 ohms to 470 ohms; C7 changed from 220 nF to 47 nF; R27 changed from 56 ohms to 470 ohms; small heatsink H1 is added and attached to axial diode D9; C30 is stuffed.	VC / AM
Feb 18, 2005	DZ	3.0	Add OV/UV resistor; improve frequency reduction circuit,	AM / VC



For the latest updates, visit our Web site: www.powerint.com

Power Integrations may make changes to its products at any time. Power Integrations has no liability arising from your use of any information, device or circuit described herein nor does it convey any license under its patent rights or the rights of others. POWER INTEGRATIONS MAKES NO WARRANTIES HEREIN AND SPECIFICALLY DISCLAIMS ALL WARRANTIES INCLUDING, WITHOUT LIMITATION, THE IMPLIED WARRANTIES OF MERCHANTABILITY, FITNESS FOR A PARTICULAR PURPOSE, AND NON-INFRINGEMENT OF THIRD PARTY RIGHTS.

PATENT INFORMATION

The products and applications illustrated herein (including circuits external to the products and transformer construction) may be covered by one or more U.S. and foreign patents or potentially by pending U.S. and foreign patent applications assigned to Power Integrations. A complete list of Power Integrations' patents may be found at www.powerint.com.

The PI Logo, **TOPSwitch**, **TinySwitch**, **LinkSwitch**, and **EcoSmart** are registered trademarks of Power Integrations. **PI Expert** and **DPA-Switch** are trademarks of Power Integrations.
© Copyright 2004, Power Integrations.

Power Integrations Worldwide Sales Support Locations

WORLD HEADQUARTERS

5245 Hellyer Avenue,
San Jose, CA 95138, USA
Main: +1-408-414-9200
Customer Service:
Phone: +1-408-414-9665
Fax: +1-408-414-9765
e-mail:
usasales@powerint.com

CHINA (SHANGHAI)

Rm 807, Pacheer,
Commercial Centre,
555 Nanjing West Road,
Shanghai, 200041, China
Phone: +86-21-6215-5548
Fax: +86-21-6215-2468
e-mail:
chinasales@powerint.com

CHINA (SHENZHEN)

Rm# 1705, Bao Hua Bldg.
1016 Hua Qiang Bei Lu,
Shenzhen, Guangdong,
518031, China
Phone: +86-755-8367-5143
Fax: +86-755-8377-9610
e-mail:
chinasales@powerint.com

APPLICATIONS HOTLINE

World Wide +1-408-414-9660

GERMANY

Rueckertstrasse 3,
D-80336, Munich, Germany
Phone: +49-89-527-3910
Fax: +49-89-527-3920
e-mail: eurosales@powerint.com

INDIA (TECHNICAL SUPPORT)

Innovatech
261/A, Ground Floor
7th Main, 17th Cross,
Sadashivanagar
Bangalore, India, 560080
Phone: +91-80-5113-8020
Fax: +91-80-5113-8023
e-mail: indiasales@powerint.com

ITALY

Via Vittorio Veneto 12, Bresso,
Milano,
20091, Italy
Phone: +39-028-928-6001
Fax: +39-028-928-6009
e-mail: eurosales@powerint.com

APPLICATIONS FAX

World Wide +1-408-414-9760

JAPAN

Keihin-Tatemono 1st Bldg.
12-20 Shin-Yokohama,
2-Chome,
Kohoku-ku, Yokohama-shi,
Kanagawa 222-0033, Japan
Phone: +81-45-471-1021
Fax: +81-45-471-3717
e-mail:
japansales@powerint.com

KOREA

8th Floor, DongSung Bldg.
17-8 Yoido-dong,
Youngdeungpo-gu,
Seoul, 150-874, Korea
Phone: +82-2-782-2840
Fax: +82-2-782-4427
e-mail:
koreasales@powerint.com

SINGAPORE

51 Newton Road,
#15-08/10 Goldhill Plaza,
Singapore, 308900
Phone: +65-6358-2160
Fax: +65-6358-2015
e-mail:
singaporesales@powerint.com

TAIWAN

17F-3, No. 510,
Chung Hsiao E. Rd., Sec. 5,
Taipei, Taiwan 110, R.O.C.
Phone: +886-2-2727-1221
Fax: +886-2-2727-1223
e-mail:
taiwansales@powerint.com

UK (EUROPE & AFRICA HEADQUARTERS)

1st Floor, St. James's House
East Street
Farnham, Surrey GU9 7TJ
United Kingdom
Phone: +44-1252-730-140
Fax: +44-1252-727-689
e-mail: eurosales@powerint.com

ER or EPR template – Rev 3.6 – Single sided

