

B5-430-JD

DESCRIPTION

- Super bright LED Lamp
- Round type
- T1-3/4 (5mm) diameter
- Lens color: Water Clear
- With Flange
- Solder leads without stand-off

FEATURES

- Emitted color: White
- High Luminous intensity
- Technology: InGaN
- Typical emission color: x=0.31, y=0.32
- Viewing angle: 30 °

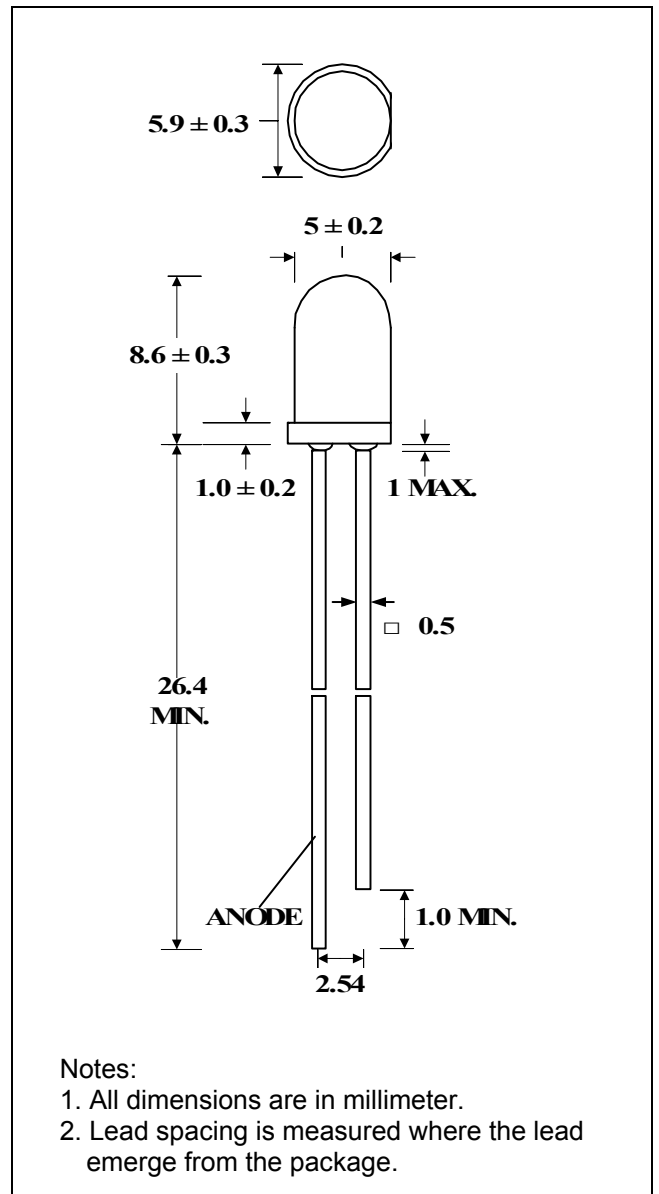

SELECTION GUIDE

Chip Material	Emitted Color	Lens Color	Viewing Angle
InGaN	White	Water Clear	30 °

B5-430-JD

ABSOLUTE MAXIMUM RATINGS

(Ta=25 °C)

PARAMETER	SYMBOL	MAX. RATING	Unit
Power Dissipation	P _D	120	mW
Peak Forward Current (1/10 Duty Cycle @1KHz)	I _{PF}	100	mA
Continuous Forward Current	I _{AF}	30	mA
Reverse Voltage	V _R	5.0	V
Operating Temperature Range	T _{OPR}	-20~+80	°C
Storage Temperature Range	T _{STG}	-30~+100	°C

Solder temperature 1.6 mm from body for 3 seconds at 260 °C

OPTICAL-ELECTRICAL CHARACTERISTICS

PARAMETER	SYMBOL	TEST CONDITION	MIN	TYP	MAX	UNIT
Luminous Intensity	I _v	I _F = 20mA	2400	3500		mcd
Forward Voltage	V _F	I _F = 20mA		3.5	4.0	V
Reverse Current	I _R	V _R = 5V			10	uA
Viewing Angle	2θ1/2	I _F = 20mA		30		deg.

*Tolerance of Viewing Angle: -10 / +5 deg.

B5-430-JD

TYPICAL OPTICAL-ELECTRICAL CHARACTERISTIC CURVES

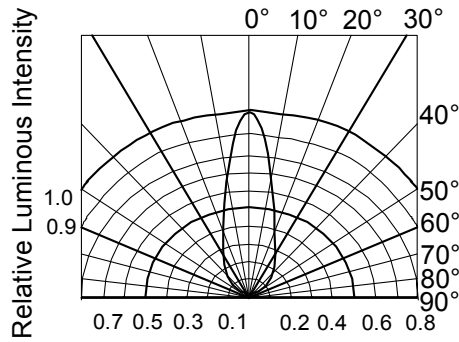

RADIATION DIAGRAM

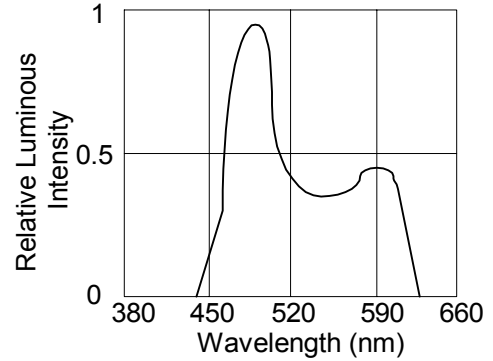

RELATIVE LUMINOUS INTENSITY Vs. WAVELENGTH

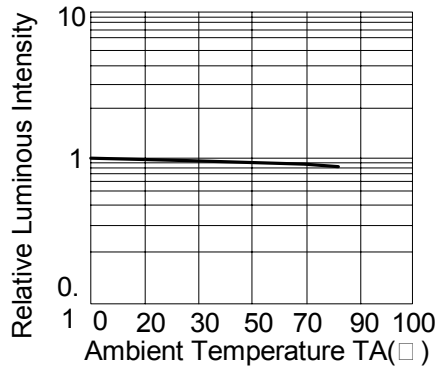

LUMINOUS INTENSITY Vs. AMBIENT TEMPERATURE

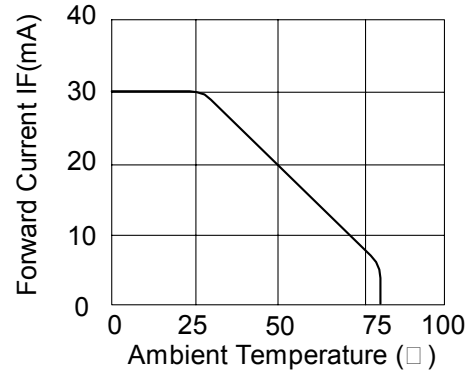

FORWARD CURRENT Vs. AMBIENT TEMPERATURE

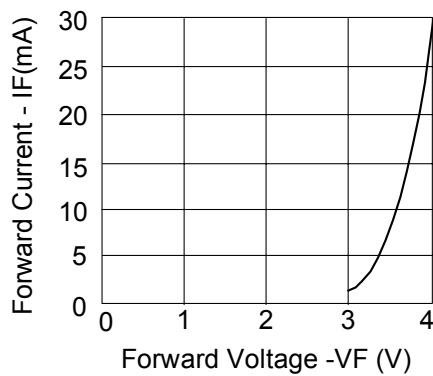

FORWARD CURRENT Vs. FORWARD VOLTAGE

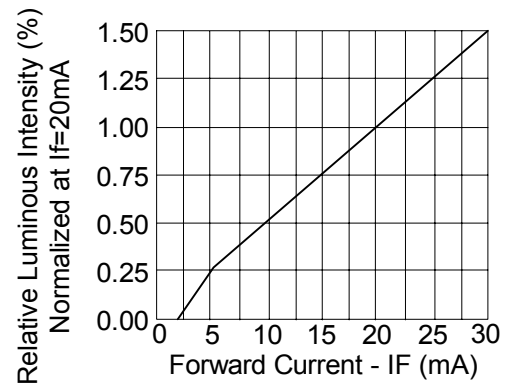

LUMINOUS INTENSITY Vs. FORWARD CURRENT