

1.0 General Description

The AMIS-710251-A6 (PI251MC-A6) is a contact imaging sensor (CIS) module. It is a successor module to its predecessor, AMIS-710222-A6 (PI222MC-A6). This possesses all qualities of its predecessor, except, it has one outstanding feature - it operates from a single 5V supply. Like its predecessor, it is composed of 13 AMIS-720220 (PI3020) sensor chips. The AMIS-720220 is a 200 dots per inch (dpi) solid-state line imaging array, also a product of AMI Semiconductor. This imaging device is fabricated using MOS imaging sensor technology for its high-speed performance and high sensitivity. Like its predecessor, the AMIS-710251-A6 is suitable for scanning A6 size (104mm) documents with 8 dots per millimeter (dpm) resolution. Applications include ticket, check and card scanners, variety of mark readers and other automation equipment.

2.0 Key Features

- Low power-single power supply at 5.0V
- Light source, lens and sensor are integrated into a single module
- 8dpm resolution, 104mm scanning length
- High speed page scan - up to 167µsec/line @ 5MHz pixel rate
- Wide dynamic range
- Analog output
- Yellow-Green LED light source
- Compact size \cong 14mm x 19mm x 120mm
- Light weight

3.0 Functional Description

The AMIS-710251-A6 consists of 13 imaging array sensors that are cascaded to provide 832 photo-detectors. Each sensor contains its associated multiplex switches, and a digital shift register that controls its sequential readout. Each sensor also contains a chip-select switch so that each following chip is accessed sequentially as its predecessor chip completes its scan. These chips are mounted on a printed circuit board (PCB) along with clock buffers and video signal amplifier. The only change from its predecessor module is in this amplifier. It has been slightly altered to gain the single supply feature through the application of the new rail-to-rail single volt operational amplifiers. See Figure 1.

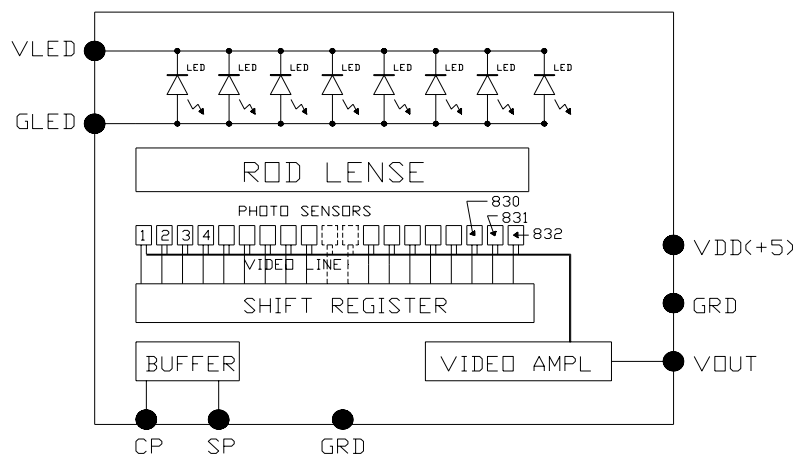

Figure 1: AMIS-710251-A6 Module Block Diagram

The PCB containing the imaging array is enclosed in a module housing, along with a one-to-one graded indexed micro lens array that focuses the scanned documents' image onto the sensing line of the sensor chips. The document is illuminated with a LED light source which is also mounted in the housing. See Figure 2.

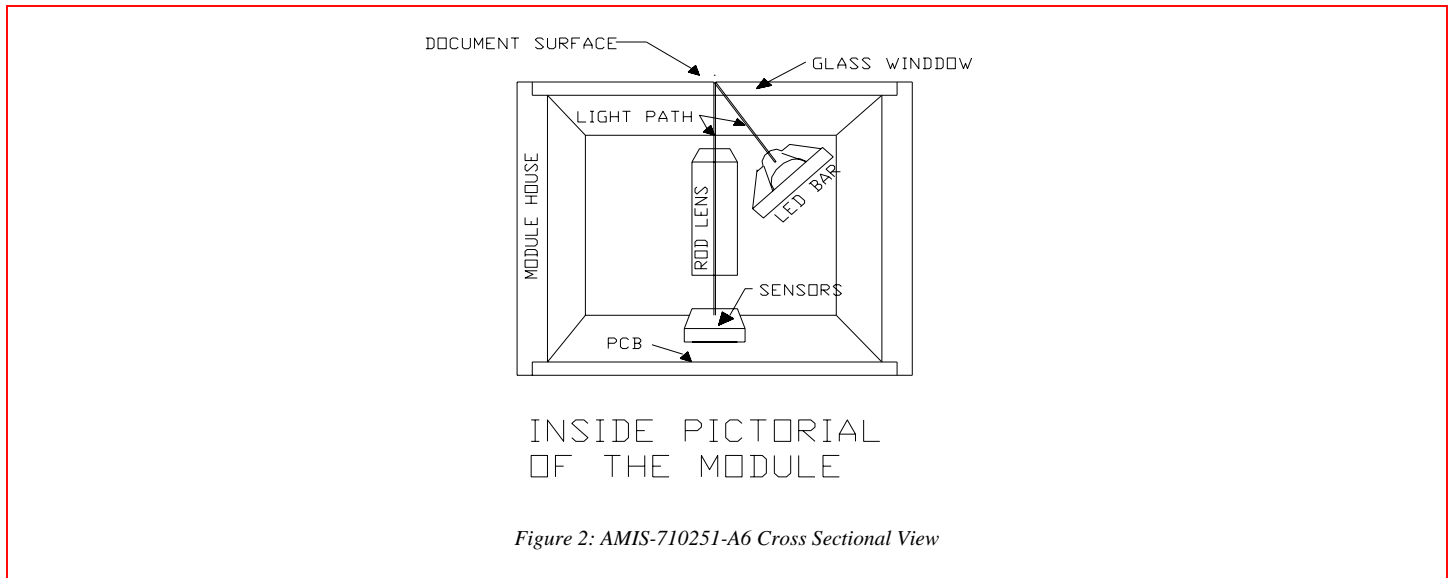

Figure 2: AMIS-710251-A6 Cross Sectional View

This pictorial cross section shows the LED bar light source and its illumination path. The light on the document reflects images of the document. The reflected images focus through the micro lens onto the chips' image sensing line where images are converted to proportional electrical charges. An on board amplifier processes these signal charges into proportional video signal voltages, which are sent out to the output video port.

All components are housed in a small plastic housing and covered with a glass window. This cover glass not only serves to protect all of the critical components within the housing from dust, but, along with micro lens, plays a minor role in the depth-of-focus because it lies in the optical path.

4.0 Pin Out Description

There is one connector located at the end of the module. The outline of the module's housing in Figure 4 illustrates the connector location. With the module window facing down on the flat surface, the viewer looking down on backside of the module and the connector's pins facing viewer, the connector is located on the right-hand end of the module. The connector is a single row of 10-pin with a 1.25mm pin space. It is a JAE 1L-Z-10P-S125T3-E. Its I/O designation is provided in Table 1. The location of Pin 1 is indicated on the module outline.

Table 1: I/O Designation

Pin Number	Symbol	Names and Functions
1	Vout	Analog video output
2	Gnd (0V)	Ground
3	Vdd (+5V)	Positive power supply
4	NA	Not used
5	Gnd (0V)	Ground
6	SP	Shift register start pulse
7	Gnd (0V)	Ground
8	CP	Sampling clock pulse
9	GLED	Ground for the light source
10	VLED	Supply for the light source

5.0 Absolute Maximum Rating

The following is a table of absolute maximum parameters. These parameters should not be used in prolonged operation.

Table 2: Absolute Maximum Rating

Parameter	Symbols	Maximum Rating	Units
Power supply	Vdd	7.0	V
	Idd	50	mA
	VLED	6.0	V
	ILED	650	mA
Input clock pulse (high)	Vih	Vdd	V
Input clock pulse (low)	Vil	-0.5	V

Table 3: Operating Environment

Parameter	Symbols	Maximum Rating	Units
Operating temperature	Top	0 to 50	°C
Operating humidity	Hop	10 to 85	%
Storage temperature	Tstg	-25 to 85	°C
Storage humidity	Hstg	5 to 95	%

6.0 Electro-Optical Characteristics (25°C)

Table 4: Electro-Optical Characteristics (25°C)

Parameter	Symbol	Parameter	Units	Note
Number of photo detectors		832	Elements	
Pixel-to-pixel spacing		125	µm	
Line scanning rate	Tint ⁽¹⁾	170	µsec	@ 5MHz clock frequency
Clock frequency ⁽²⁾	Fclk	5	MHz	
Bright output voltage ⁽³⁾	Video output	1.0	V	Specified for Tint = 170µsec
Bright output non-uniformity ⁽⁴⁾	Up	<+/-30	%	
Adjacent pixel non-uniformity ⁽⁵⁾	Uadj	<25	%	
Dark non-uniformity ⁽⁶⁾	Ud	<50	mV	
Dark output voltage	Vd	275<Vd<325	mV	
Modulation transfer function ⁽⁷⁾	MTF	>40	%	See Note 7 for MTF & DOF

Definition:

- Tint: line scanning rate or integration time. Tint is determined by the interval of two SP.
- Fclk: main clock frequency applied to into the module. It is also equal to the pixel frequency.
- $V_{pavg} = \sum V_p(n)/832$; where $V_p(n)$ is the n^{th} pixel voltage value
- U_p is defined as follows: $U_{pmax} = [(V_{pmax} - V_{pavg}) / V_{pavg}] \times 100\%$ and $U_{pmin} = [(V_{pavg} - V_{pmin}) / V_{pavg}] \times 100\%$; where U_{pmax} is determined by the highest n^{th} video pixel, $V_p(n)$, and V_{pmin} is determined by minimum pixel, $V_p(n)$, then U_p is selected from the largest of the two values $|U_{pmax}|$ or $|U_{pmin}|$.
- U_{adj} is between two adjacent pixel's non-uniformity and defined as follows.
 $U_{adj} = \text{MAX}[|(V_p(n) - V_p(n+1)) / V_p(n)| \times 100\%$
- $U_d = V_{dmax} - V_{dmin}$
 V_{dmin} is the minimum output in the dark.
 V_{dmax} : maximum output voltage in the light.
- $MTF = [(V_{max} - V_{min}) / (V_{max} + V_{min})] \times 100 \%$. Depth of focus, DOF, range is defined with the MTF
MTF is measured at glass surface to approximately 0.4mm from the glass surface, and is > 40 percent with its peaks at approximately mid-point, 0.2mm.
 V_{max} : maximum output voltage at 50lp/inch (At 1/2 of the optical Nyquist frequency)
 V_{min} : minimum output voltage at 50lp/inch
- lp / inch: line pair per inch

Table 5: Recommended Operating Conditions (25°C)

Item	Symbol	Min.	Mean	Max.	Units
Power supply	Vdd	4.5	5.0	5.5	V
	VLED	4.5	5.0	5.5	V
	Idd	30	35	40	ma
	ILED	200	360	480	ma
Input voltage at digital high	Vih	Vdd-1.0	Vdd-0.5	Vdd	V
Input voltage at digital low	Vil	0		0.6	V
Clock frequency ⁽¹⁾	Fclk		5.0	5.5	MHz
Clock pulse high duty cycle ⁽²⁾		25			%
Clock pulse high duration ⁽³⁾		50			ns
Integration time ⁽³⁾	Tint	0.167		5.0	ms
Operating temperature	Top		25	50	°C

Notes:

1. The module will operate at 5.5MHz, but its performances cannot be guaranteed.
2. Clock duty cycle is defined as the ratio of the high level duration divided by the duration of the clock period.
3. Tint (min.) is the lowest line integration time available at 5.0MHz clock rate.

7.0 Switching Characteristics (25°C)

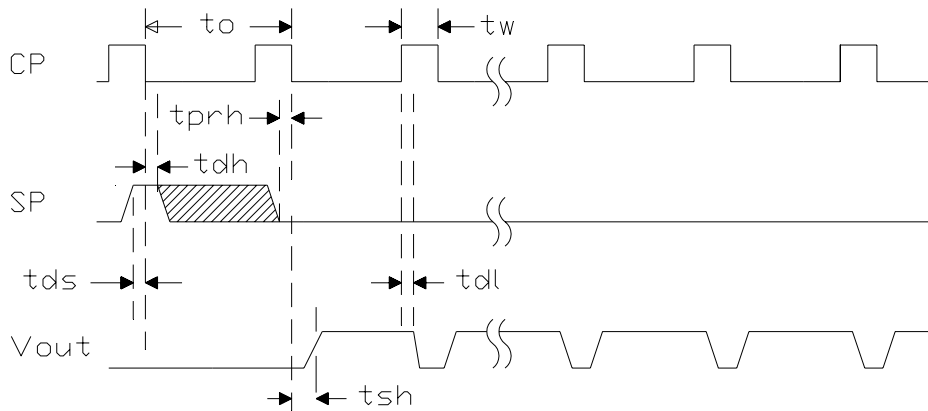

MODULE TIMING DIAGRAM

Figure 3: Clock and Start Pulse Timing Diagram

The switching characteristics for the I/O clocks are shown in Figure 3. Its corresponding timing symbol definitions are given in Table 6.

Table 6: Symbol Definition for the Above Timing Diagram

Item	Symbol	Min.	Typ.	Max.	Units
Clock cycle time	to	0.2		4.0	μs
Clock pulse width	tw	50			ns
Clock duty cycle		25		75	%
Prohibit crossing time of SP	tprh	15			ns
Data setup time	tds	20			ns
Data hold time	tdh	20			ns
Signal delay time	tdl	50			ns
Signal settling time	tsh	120			ns

8.0 AMIS-710251-A6 Module and its Mechanical Dimensions

The sketch of this module is to provide a pictorial of the module size and structure. A detailed drawing is available upon request.

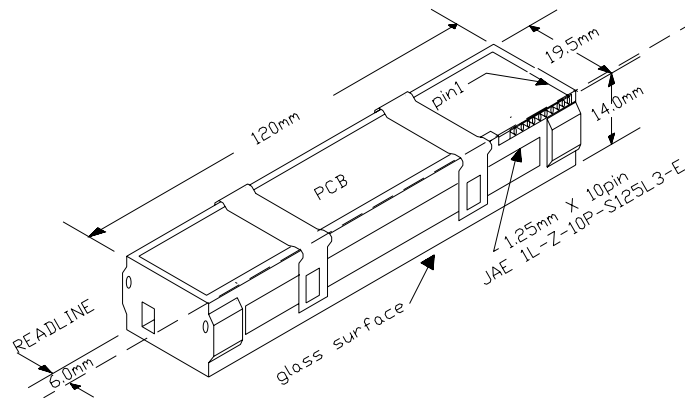

Pictorial of The Plastic Standard A6 Housing Size

Figure 4: AMIS-710251-A6 Module Mechanical Outline

9.0 Company or Product Inquiries

For more information about AMI Semiconductor, our technology and our product, visit our Web site at: <http://www.amis.com>

North America

Tel: +1.208.233.4690

Fax: +1.208.234.6795

Europe

Tel: +32 (0) 55.33.22.11

Fax: +32 (0) 55.31.81.12

Production Technical Data - The information contained in this document applies to a product in production. AMI Semiconductor and its subsidiaries ("AMIS") have made every effort to ensure that the information is accurate and reliable. However, the characteristics and specifications of the product are subject to change without notice and the information is provided "AS IS" without warranty of any kind (express or implied). Customers are advised to obtain the latest version of relevant information to verify that data being relied on is the most current and complete. AMIS reserves the right to discontinue production and change specifications and prices at any time and without notice. Products sold by AMIS are covered by the warranty and patent indemnification provisions appearing in its Terms of Sale only. AMIS makes no other warranty, express or implied, and disclaims the warranties of noninfringement, merchantability, or fitness for a particular purpose. AMI Semiconductor's products are intended for use in ordinary commercial applications. These products are not designed, authorized, or warranted to be suitable for use in life-support systems or other critical applications where malfunction may cause personal injury. Inclusion of AMIS products in such applications is understood to be fully at the customer's risk. Applications requiring extended temperature range, operation in unusual environmental conditions, or high reliability, such as military or medical life-support, are specifically not recommended without additional processing by AMIS for such applications. Copyright © 2006 AMI Semiconductor, Inc.