

## Internal Pull-up Hall Effect Latch

### ■ Features

- Bipolar Hall effect latch sensor
- 2.2V to 20V DC operation voltage
- Built-in pull-up resistor
- 25mA output sink current
- Operating temperature:  $-40^{\circ}\text{C} \sim +125^{\circ}\text{C}$
- Package: SIP3, SOT23

### ■ Applications

- Rotor position sensing
- Current switch
- Encoder
- RPM detection

### ■ General Description

AH373 is a single-digital-output Hall-effect sensor with pull-up resistor for high temperature operation. The device includes an on-chip Hall voltage generator for magnetic sensing, an amplifier to amplify Hall voltage, and a comparator to provide switching hysteresis for noise rejection, and an output driver with a pull-up resistor (Rpu). An internal bandgap regulator is used to provide temperature compensated supply voltage for internal circuits and allows a wide operating supply range. While the magnetic flux density (B) is larger than operate point (Bop), the OUT pin turns on (low). If B moves toward release point (Brp), the OUT pin is latched "on" state prior to  $B < \text{Brp}$ . When  $B < \text{Brp}$ , the OUT pin go into "off" state.

### ■ Pin Assignment

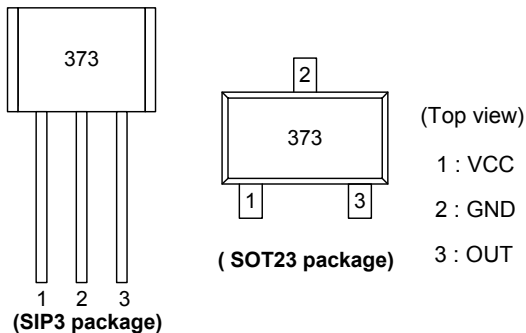

### ■ Pin Descriptions

Name	Description
VCC	Positive Power Supply
GND	Ground
OUT	Output Pin

### ■ Ordering Information

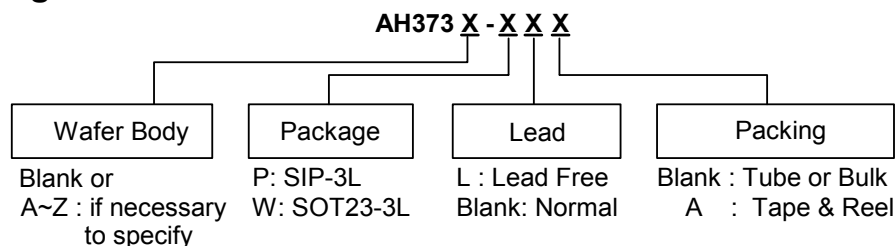

## Internal Pull-up Hall Effect Latch

### ■ Block Diagram

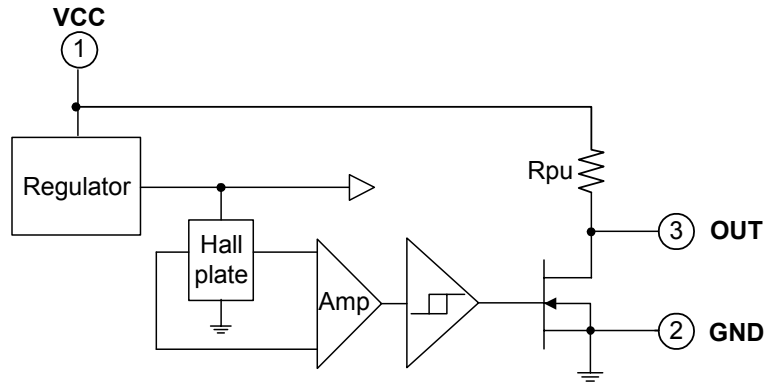

### ■ Functional Application Circuit

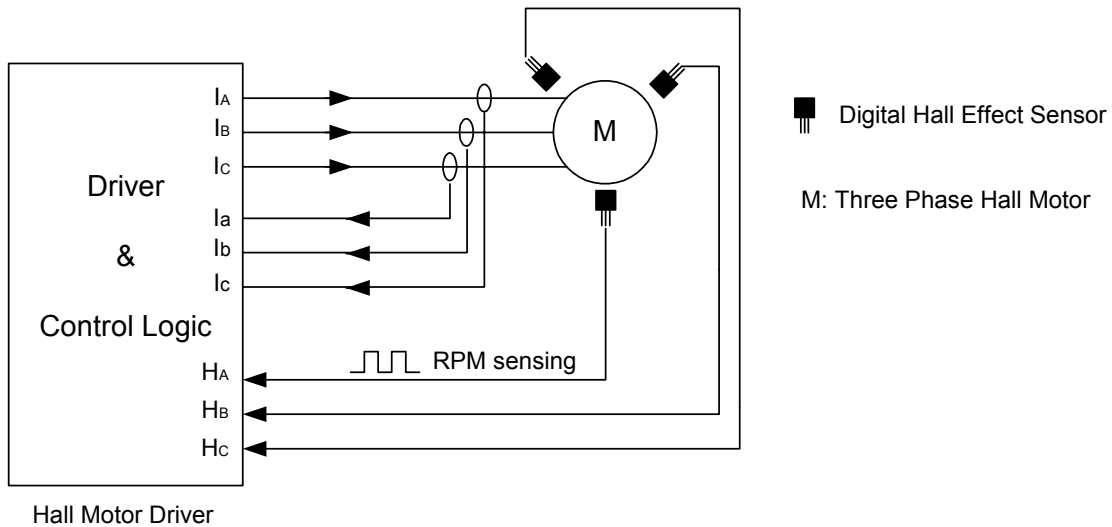

### ■ Absolute Maximum Ratings ( at Ta= 25°C )

Characteristics	Symbol	Values	Unit
Supply voltage	VCC	20	V
Output "off" voltage	Vout (off)	28	V
Output "on" current	Io (sink)	25	mA
Operating temperature range	Top	-40~+125	°C
Storage temperature range	Tstg	-65~+150	°C
Power dissipation	SIP	PD	550
	SOT23		230
			mW

## Internal Pull-up Hall Effect Latch

### ■ Electrical Characteristics ( $T_a = 25^\circ\text{C}$ , $V_{cc} = 12\text{V}$ )

Characteristics	Symbol	Conditions	Min.	Typ.	Max.	Unit
Supply voltage	$V_{cc}$	—	2.2*	-	20	V
Output saturation voltage	$V_{out(sat)}$	$I_{out} = 20\text{mA}$	-	300	400	mV
Output Leakage Current	$I_{off}$	$B < Brp$	-	<0.1	10	$\mu\text{A}$
Supply current	$I_{cc}$	OUT "OFF"	-	2	4	mA
Internal pull-up resistor	$R_{pu}$	—	7	10	13	$\text{K}\Omega$

\*Note: The output of IC will be switched after the supply voltage is over 2.2V, but the magnetic characteristics won't be normal until the supply is over 2.5V.

### ■ Magnetic Characteristics ( $T_a = 25^\circ\text{C}$ , $V_{cc} = 2.5\text{V to } 20\text{V}$ )

(1mT=10Gauss)

Parameter	Symbol	Min.	Typ.	Max.	Unit
Operate Point	$B_{op}$	5	30	60	Gauss
Release Point	$B_{rp}$	-60	-30	-5	Gauss
Hysteresis	$B_{hys}$	-	60	-	Gauss

### ■ Operating Characteristics

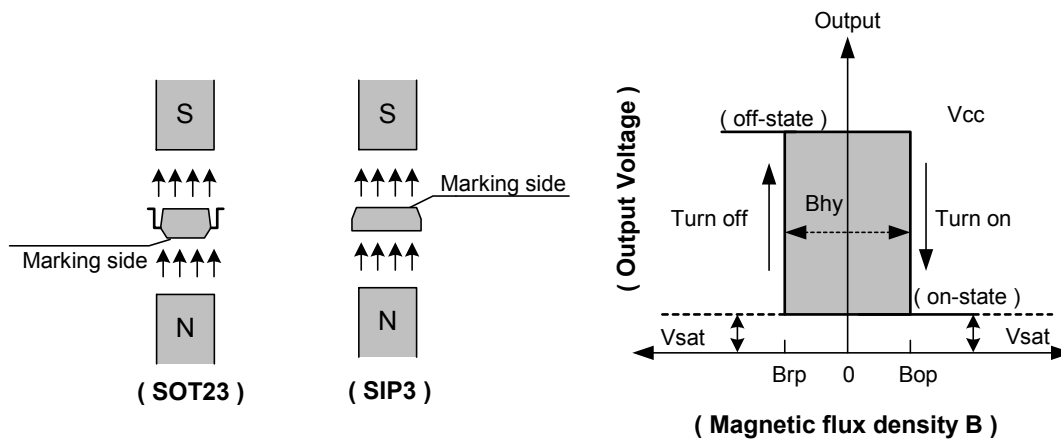

## Internal Pull-up Hall Effect Latch

### ■ Performance Characteristics (SIP3)

Ta (°C)	25	50	60	70	80	85	90	95	100
Pd (mW)	550	440	396	352	308	286	264	242	220
Ta (°C)	105	110	115	120	125	130	135	140	150
Pd (mW)	198	176	154	132	110	88	66	44	0

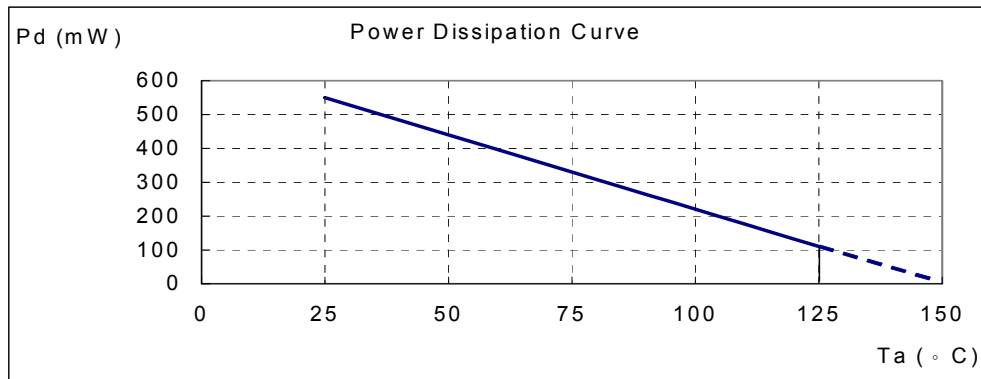

### ■ Performance Characteristics (SOT23-3)

Ta (°C)	25	50	60	70	80	90	100	110	120	125	130	140	150
Pd (mW)	230	184	166	147	129	110	92	74	55	46	37	18	0

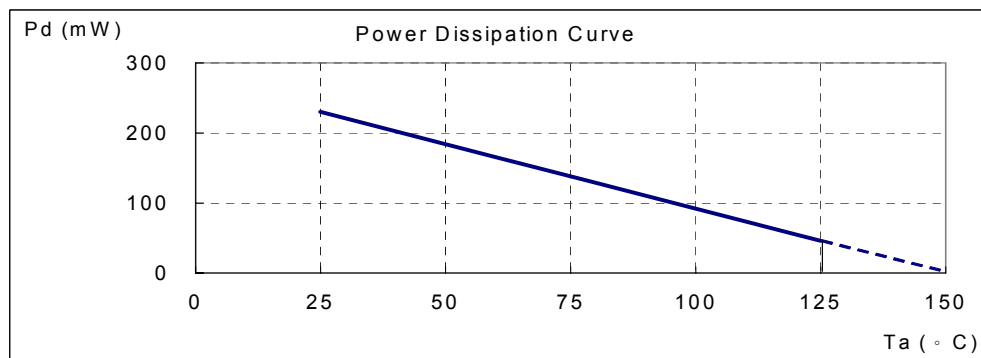

## Internal Pull-up Hall Effect Latch

### ■ Marking Information

#### (1) SIP3

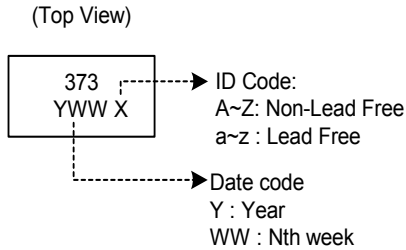

#### (2) SOT23

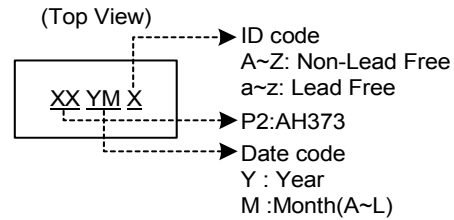

### ■ Package Information

#### (1) Package Type: SIP-3L

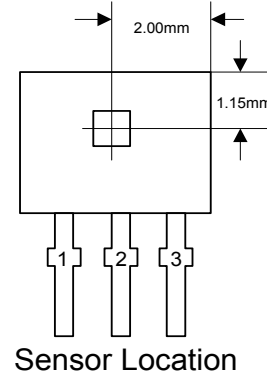
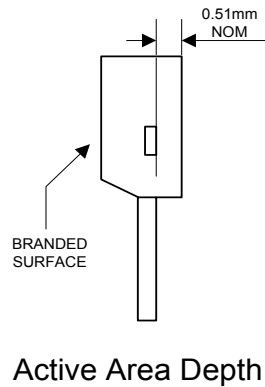

#### Package Dimension

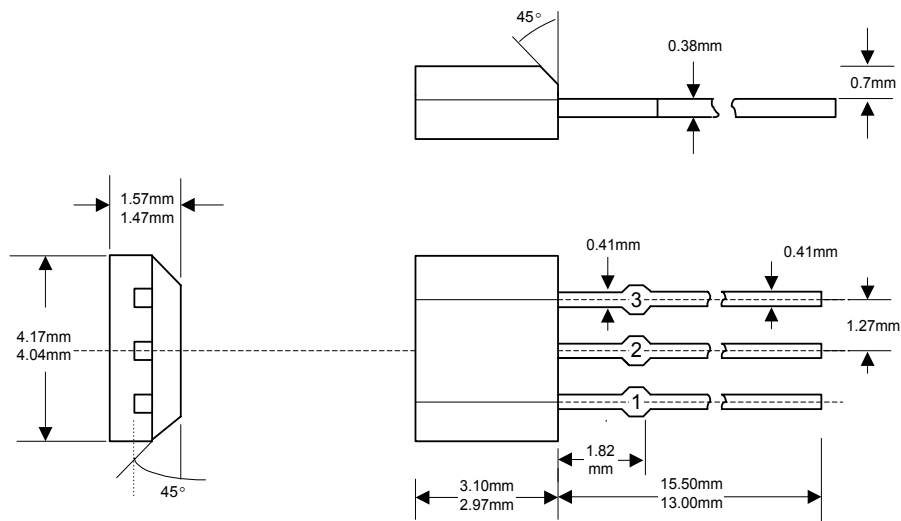

## Internal Pull-up Hall Effect Latch

(2) Package Type: SOT23-3L

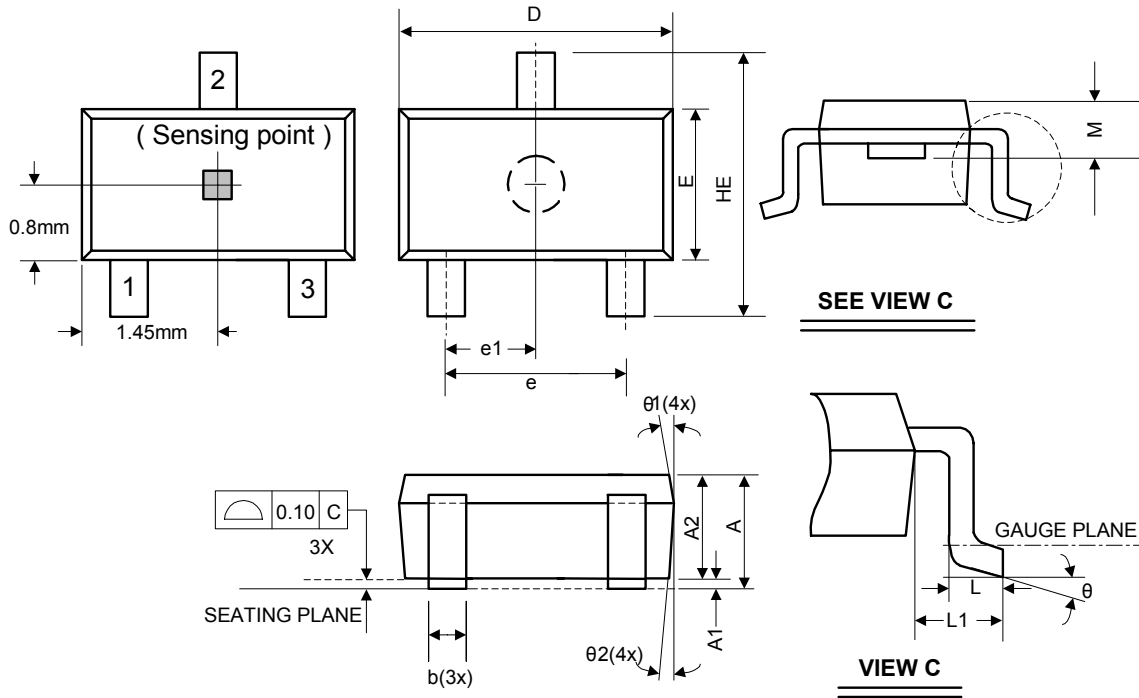

Symbol	Dimensions In Millimeters			Dimensions In Inches		
	Min.	Nom.	Max.	Min.	Nom.	Max.
A	1.05	-	1.35	0.041	-	0.053
A1	0.05	-	0.15	0.002	-	0.006
A2	1.00	1.10	1.20	0.039	0.043	0.047
b	0.25	-	0.50	0.010	-	0.020
C	0.08	-	0.20	0.003	-	0.008
D	2.70	2.90	3.00	0.106	0.114	0.118
E	1.50	1.60	1.70	0.059	0.063	0.067
HE	2.60	2.80	3.00	0.102	0.110	0.118
L	0.30	-	0.55	0.012	-	0.022
L1	0.50	0.60	0.70	0.020	0.024	0.028
M	0.73	0.78	0.83	0.029	0.031	0.033
e	1.80	1.90	2.00	0.071	0.075	0.079
e1	0.85	0.95	1.05	0.033	0.037	0.041
θ	0°	5°	10°	0°	5°	10°
θ1	3°	5°	7°	3°	5°	7°
θ2	6°	8°	10°	6°	8°	10°