



TELEFUNKEN ELECTRONIC

44E D ■ 8920096 0010385 8 ■ ALGG

U 263 B1 · U 263 B2

ZERO VOLTAGE SWITCH

T-65-09

Triac Temperature Control for Industrial and Domestic Purposes

Technology: Bipolar

Features:

- U 263 B1 with ramp output
- U 263 B2 with static output.
- Direct supply from the mains
- Very few external components
- Full wave drive—no d.c. current component in the load circuit
- Integrated temperature sensor
- Negative output current pulse typ. 75 mA
- Internal generated ramp for proportional control (U 263 B1)
- Zero voltage synchronised static output for simple two point driver
- Automatic pulse phase control

Case: DIP 8

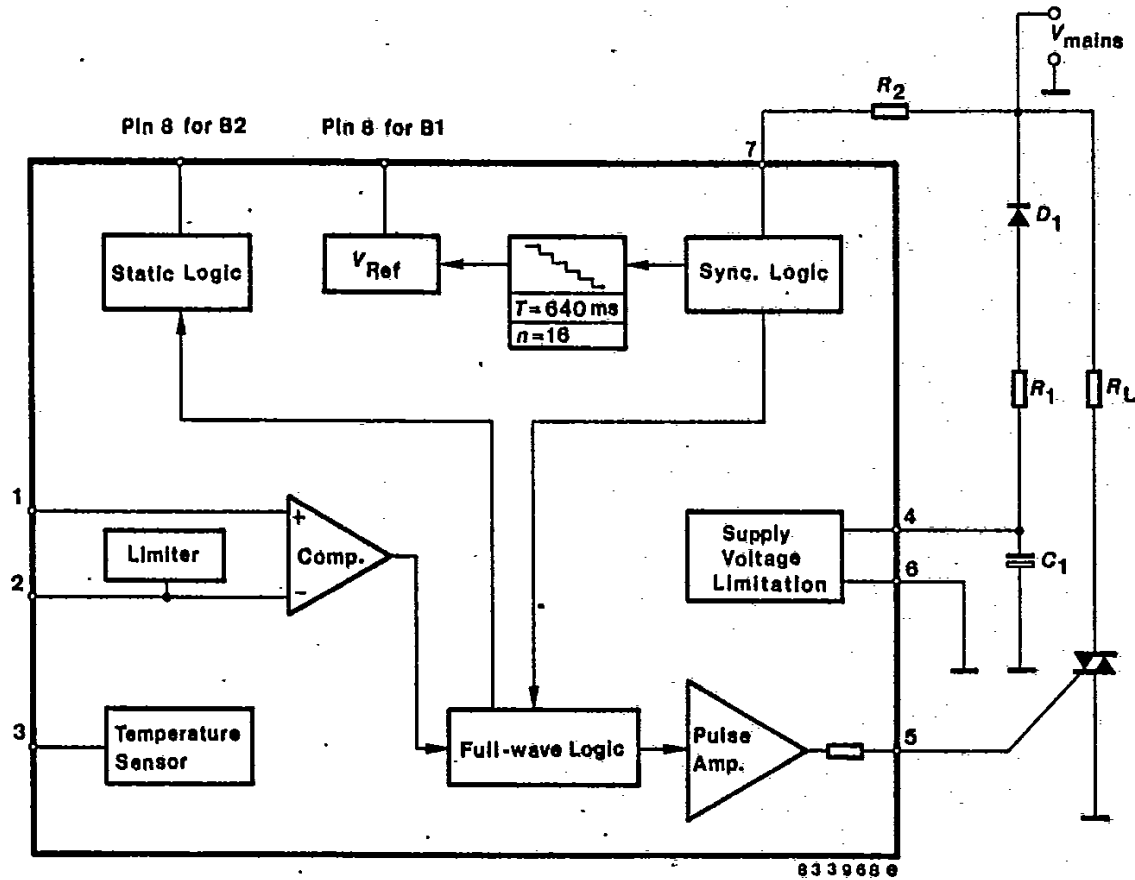

Fig. 1 Block diagram with external circuit



U 263 B1 · U 263 B2

T-65-09

TELEFUNKEN ELECTRONIC

Description

The monolithic bipolar integrated circuit described below is a triac-driver circuit working on the principle of zero-voltage-switching. Both versions available, the U 263 B1 and the U 263 B2 are like the already known types U 217 B and U 106 BS designed predominantly for resistive loads.

Power supply and its limitations

The voltage limitation contained in the U 263 B allows it to be powered from mains via series resistance R_1 and rectifying diode D_1 between Pin 6 (+Pol/L) and Pin 4 ($-V_S$). The capacitor C_1 smooths the supply voltage (see Fig. 1).

An internal temperature-compensated limiting circuit protects the module from random peaks of voltage on the mains, and during the negative half-cycle delivers a defined reference voltage.

Synchronisation

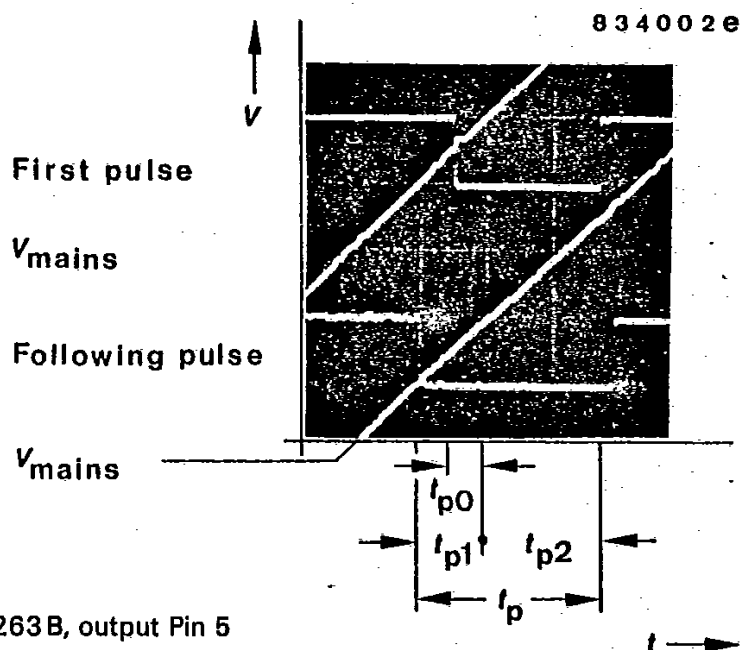

Fig. 2 Trigger pulses U 263 B, output Pin 5

The logic function is synchronised by means of a separate resistance R_2 between Pin 7 and phase (voltage-synchronisation). The width of the pulses can be varied between wide limits by choice of value of R_2 . The larger the value chosen, the wider is the output pulse on Pin 5. Automatic optimisation of the phase of the pulse is necessary, since the latching current of the triac exceeds the steady current by a factor of 3. The phase of the pulse is chosen so that ca. 1/3 of the pulse width appears before the transition through null and 2/3 after it (see electrical characteristics and Fig. 2).

In order to avoid phase-clipping after the switch-on in the case of the first pulse, in the U 263 B the first third of the initial pulse is automatically suppressed.

Full-wave logic

The full-wave logic ensures that only pairs of pulses can be released, and that these always begin with the positive dv/dt . The load is thus switched on for a minimum of one complete mains cycle, which means that the triac receives a minimum of 2 driving pulses, so that the unwanted d.c. component in the load circuit is definitely eliminated.

Pulse amplifier

The pulse amplifier connected to the output of the full-wave logic circuit, is proof against continuous short-circuit, and delivers to Pin 5, via an integrated limiting resistance, negative output pulses of typ. 75 mA.

Temperature sensor

A voltage proportional to the chip or case temperature, with a temperature coefficient typically $TK_{typ} = 10.7 \text{ mV/K}$ is available at Pin 3. At 25 °C this voltage is $V_T = -3 \text{ V}$.



U 263B1 · U 263B2

TELEFUNKEN ELECTRONIC T-65-09

Comparator

The comparison of set value and measured value is carried out via the two comparator inputs Pin 1 and Pin 2. Here Pin 2 is the inverting input and has a circuit protecting it against interference spikes. Fig. 3 shows the protective circuit of the comparator. Pin 1 is the non-inverting input.

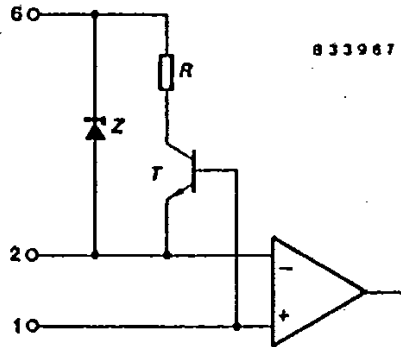

Fig. 3 Protective circuit of the comparator

The only essential difference between the two versions B 1 and B 2 is in the function of Pin 8 (compare block diagram). In version B 1 a ramp voltage (Fig. 4) derived from the mains frequency via a digital-analogue converter is provided at Pin 8. This ramp function, which is necessary for the realisation of proportional control, is made available without additional external components. The ramp, programmed by the D/A-converter to a duration of 640 ms and having 16 steps, is suitable for a typical load of 750 W meeting the Flicker Standard (EN 60555).

Fig. 4 Ramp function of the U 263B1

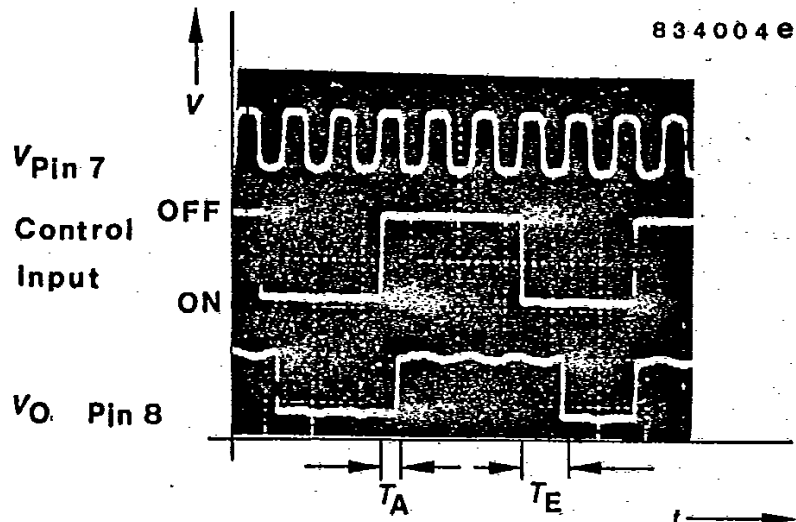
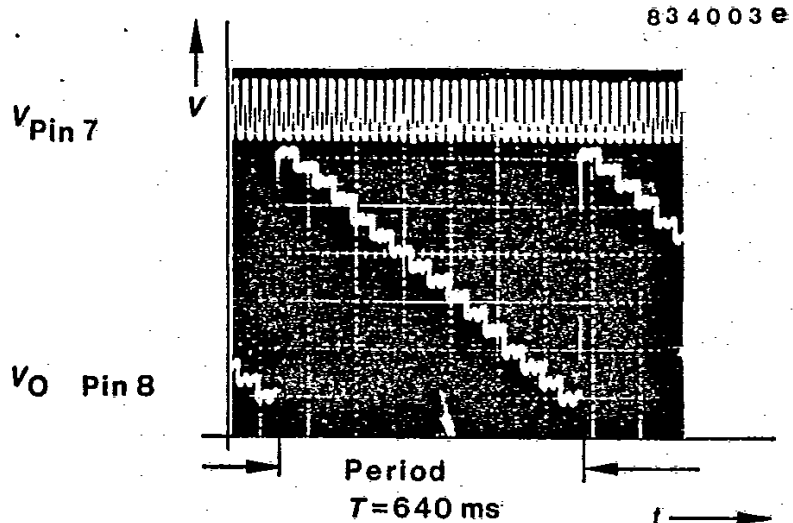

Fig. 5 Static output U 263B2



U 263 B1 · U 263 B2

TELEFUNKEN ELECTRONIC

Instead of a ramp voltage, the U 263 B2 provides at Pin 8 a zero-synchronised static output pulse with two defined states – V_S and high-resistance (open-collector), Fig.5. The signal appears at the time of the first positive transition through zero after the switch-on command. Because of the full-wave logic, only in the negative half-cycle can the signal alter to the "off" condition. Using the U 263 B2 the simplest kind of two-point control can be realised, which can switch either resistive or inductive loads.

Ramp generator, Fig. 6

Ramp voltage which is generated in the IC is available at reference Pin 8. Current sink which is controlled by D/A converter influences the internal reference voltage at Pin 8 specified by voltage divider.

The current sink is turned-off in the reset state of the D/A converter so that the voltage at Pin 8 is primarily specified via internal voltage divider (ramp starting voltage).

In the maximum state of the 4 stage D/A converter, current sink overtake the maximum current, whereby the ramp final (end) voltage has reached.

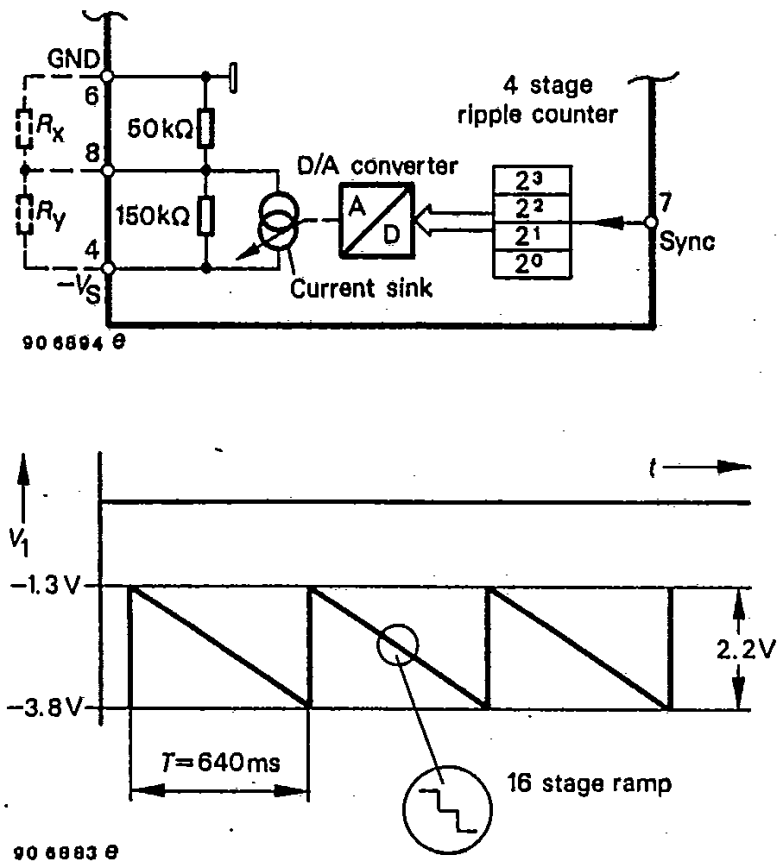

**Fig. 6 Principle diagram
Generation and evaluation of ramp**

**U 263 B1 · U 263 B2****TELEFUNKEN ELECTRONIC****Design guide for mains supply**

The value of resistance R_1 shown in Fig. 1 depends on the total current (I_{tot}) consumption, which is as follows:

T-65-09

$$I_{tot} = I_{smax} + I_x + I_p \text{ whereas,}$$

$$I_{smax} = \text{Current consumption of the integrated circuit} = 1.8 \text{ mA.}$$

$$I_x = \text{Current consumption of the external components (nominal value voltage source), } \leq 500 \mu\text{A.}$$

$$I_p = \text{Current component of the pulse output on Pin 5 which depends on the Triac and its load.}$$

Curves shown in Figs. 10, 11, 14...16 are calculated for mains supply of 220 V~. Precautions should be taken, if the dimensioning is for other than mentioned operating voltages.

- Select the triacs according to the load, with the smallest possible gate- and dynamic holding current.
- Evaluate the pulse width t_p from Fig. 10, $t_p = f(I_L, P)$.
- Determine the synchronisation resistance R_2 from Fig. 11 $R_2 = f(t_p)$.
- If a gate-series resistor R_G is necessary to reduce the gate current I_G see Fig. 12.
- Determine the maximum pulse width t_{pmax} from Fig. 20 $t_{pmax} = f(R_2)$.
- From pulse width t_{pmax} and gate current I_G and with Fig. 13 you can determine the d.c. component I_p to evaluate the resistor R_1 .
- Evaluate $R_1 = f(I_{tot})$ with the help of Fig. 14.
- Determine the power dissipation of R_1 with Fig. 15 or Fig. 16.
- Substitute smoothing condenser $C_1 \geq 47 \mu\text{F}/10 \text{ V}$.

(Because of the half wave supply the ripple on the supply voltage has no effect on the control.)

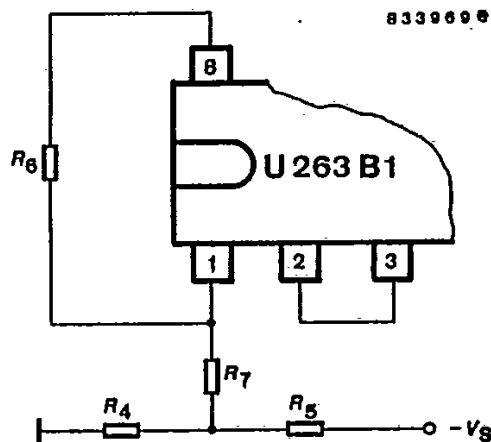
Design guide for control function U 263 B1

- From Fig. 17:

$V_{TS} = f(T_x)$, evaluate the nominal-value for the temperature voltage V_{TS} , then determine R_4 and R_5 .

- From Fig. 18:

with the desired proportional term, determine R_6 and R_7

$$R_4 + R_5 \approx 150 \text{ k}\Omega$$

Fig. 7 Component values for a proportional control with internal temperature sensor



U 263 B1 · U 263 B2

TELEFUNKEN ELECTRONIC

T-65-09

Design guide for control function U 263 B2

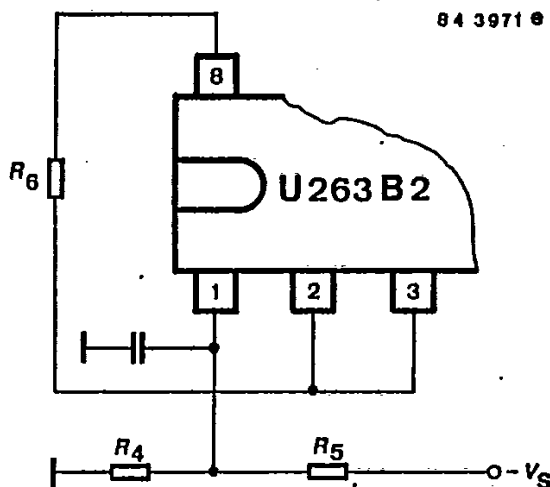

- a) From Fig. 17:
 $V_{TS} = f(T_x)$, determine the set-temperature voltage V_{TS} , then R_4 and R_5 .
- b) From Table 1 and the hysteresis desired, evaluate R_6 .

$$R_4 + R_5 \approx 150 \text{ k}\Omega$$

Fig. 8 Component values for a 2-point controller with hysteresis and internal temperature sensor

ΔT	$^{\circ}\text{C}$	ΔV mV											
		0.23	0.47	0.7	0.9	1.2	1.4	1.9	2.3	2.8	3.7	4.7	5.6
T	$^{\circ}\text{C}$	V_{TS} V											
		2.5	5	7.5	10	12.5	15	20	25	30	40	50	60
10	3.16	36	12	6.2	4.7	3.0	2.7	1.8	1.5	1.1	0.82	0.62	0.51
25	3.0	39	13	6.2	4.7	3.0	2.7	1.8	1.5	1.2	0.91	0.68	0.51
30	2.95	39	13	6.2	4.7	3.3	2.7	1.8	1.5	1.2	0.91	0.68	0.51
45	2.78	39	13	6.8	5.1	3.3	3.0	1.8	1.6	1.3	0.91	0.68	0.56
50	2.73	39	13	6.8	5.1	3.3	3.0	2.0	1.6	1.3	0.91	0.68	0.56
75	2.47	43	15	7.5	5.6	3.6	3.0	2.0	1.8	1.3	1.0	0.75	0.62
100	2.2	47	15	7.5	5.6	3.9	3.3	2.0	1.8	1.5	1.1	0.82	0.62

Table 1: Determination of the hysteresis resistor R_6 in M Ω

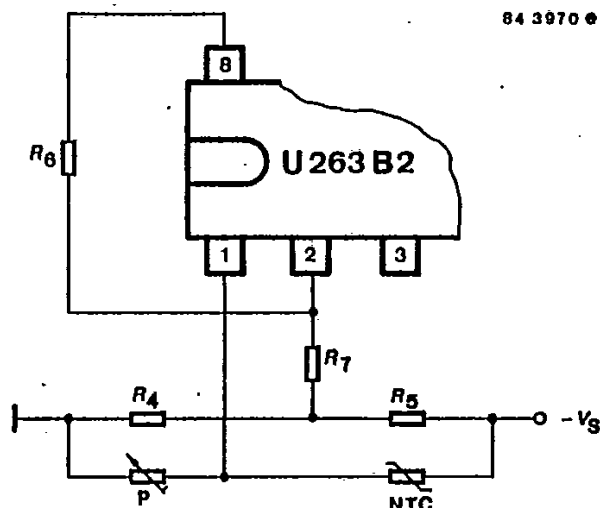

- a) as in Fig. 7
 - b) From Table 2 and the desired hysteresis, determine R_6 and R_7 .
- $$R_4 + R_5 \approx 50 \text{ k}\Omega$$

Fig. 9 Component values for a 2-point controller with hysteresis and external temperature sensor



U 263B1 · U 263B2

TELEFUNKEN ELECTRONIC

T-65-09

Absolute maximum ratings

Reference point Pin 6

Supply voltage in operation with DC voltage	Pin 4	$-V_S$	6.5	V
Current consumption	Pin 4	$-I_S$	30	mA
$t \leq 10 \mu s$	Pin 4	I_S	150	mA
Sync. current	Pin 7	I_{Sync}	5	mA
$t \leq 10 \mu s$	Pin 7	I_{sync}	20	mA
Load capability, comparator input	Pin 2	$\pm I_I$	1	mA
Load capability, temperature sensor	Pin 3	$-I_{IO}$	3	mA
		$+I_I$	10	μA
Input voltages	Pin 1,4,5,8	$-V_I$	$\leq V_S$	V
	Pin 5,8	$+V_I$	≤ 0.5	V
Power dissipation				
$T_{amb} = 45 \text{ }^\circ C$		P_{tot}	400	mW
$T_{amb} = 100 \text{ }^\circ C$		P_{tot}	125	mW
Junction temperature		T_J	150	$^\circ C$
Ambient temperature range		T_{amb}	-40...+125	$^\circ C$
Storage temperature range		T_{stg}	-40...+125	$^\circ C$

Maximum thermal resistance

Junction ambient	R_{thJA}	200	K/W
------------------	------------	-----	-----

Electrical characteristics

Supply voltage $-V_S = 6.5 \text{ V}$, $T_{amb} = 25 \text{ }^\circ C$
Reference point Pin 6, unless otherwise specified

			Min.	Typ.	Max.	
Supply voltage limitation						
$-I_4 = 1 \text{ mA}$	Pin 4	$-V_S$	5.7	6.7	7.4	V
Current consumption, d.c.	Pin 4					
positive half cycle		$-I_4$			1	mA
zero transition (Pin 5 open)		$-I_4$			1	mA
negative half cycle		$-I_4$			1.8	mA
Synchronisation						
Voltage limitation						
$\pm I_7 = 1 \text{ mA}$	Pin 7	$\pm V_I$	1.0		1.8	V
Synchronisation current	Pin 7	$\pm I_{Sync}$	0.15			mA
Zero cross detection	Pin 7	$\pm I_{Sync}$		25		μA
Comparator						
Input zero voltage	Pin 1, 2	V_{IO}		10		mV
Input bias current	Pin 1, 2	I_{IO}			1	μA
Common mode input range	Pin 1, 2	$-V_{IC}$	1		$(V_S - 1.6)$	V



U 263 B1 · U 263 B2

T-65-09

TELEFUNKEN ELECTRONIC

		Min.	Typ.	Max.	
Ramp generator					
Period	Pin 1	T	640		ms
Step number	Pin 1	n	16		
Initial voltage	Pin 1	$-V_1$	1.2	1.4	1.6 V
Final voltage	Pin 1	$-V_1$	3.3	3.6	3.9 V
Internal reference without external circuitry	Pin 1		$\left(\frac{V_S}{4}\right)$	+2.5% -7.5%	V
Temperature coefficient of internal reference	Pin 8	TK_{VRef}	± 0.6		mV/K
Temperature sensor					
Sensor voltage at 25 °C, $I_S = -1$ mA	Pin 3	$-V_{TS}$	2.75	3.0	3.25 V
Temperature coefficient	Pin 3	TK_{VTS}	10.7		mV/K
Pulse amplifier					
Output pulse current $V_G \leq 1.5$ V	Pin 5	$-I_o$	50		100 mA
Output pulse width $V_{Sync} = 220$ V \sim $R_2 = 220$ k Ω , Fig. 2	Pin 5	t_{p0}	33		μ s
		t_{p1}	65		μ s
		t_{p2}	110		μ s
Static logic					
Output current	Pin 8	$-I_o$	0.5		7 mA



U 263B1 · U 263B2

TELEFUNKEN ELECTRONIC

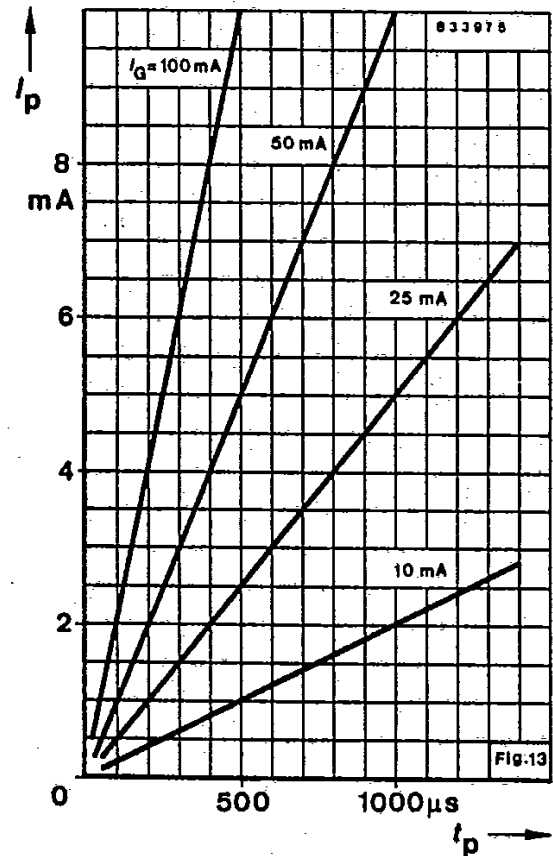
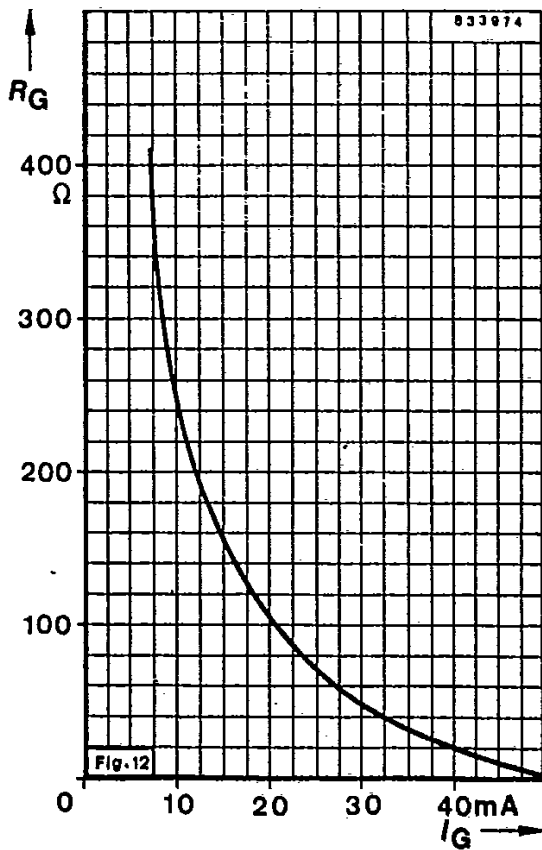
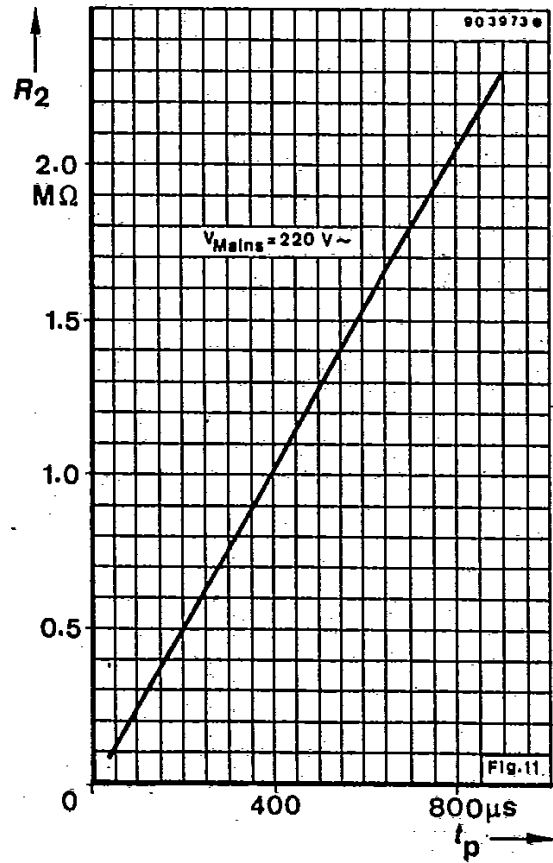
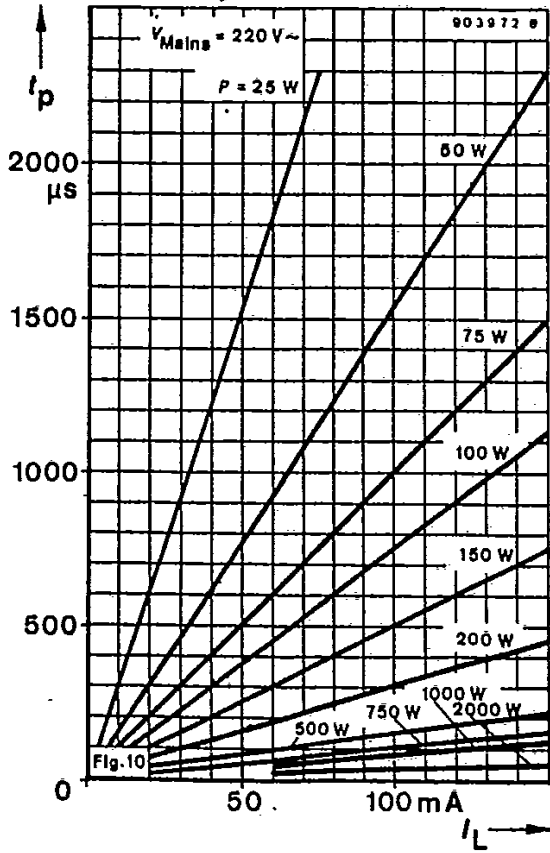



U 263B1 · U 263B2

TELEFUNKEN ELECTRONIC

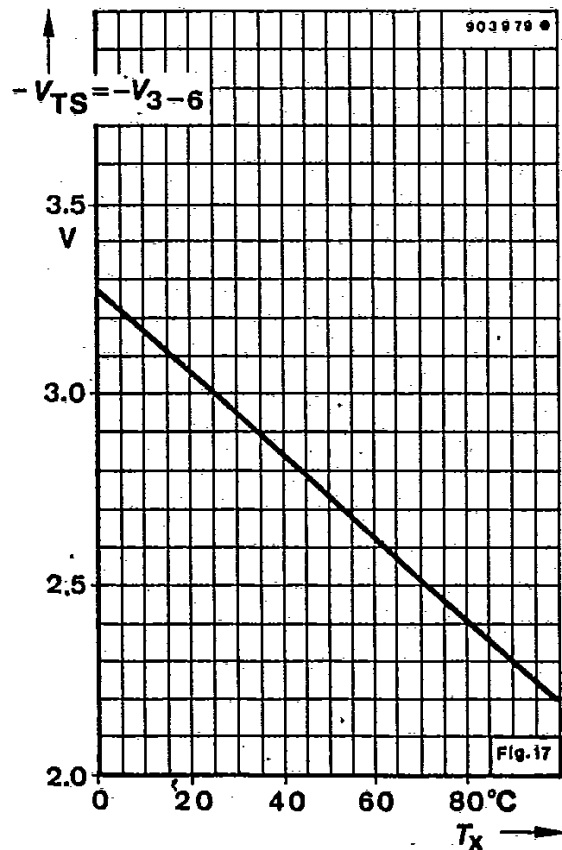
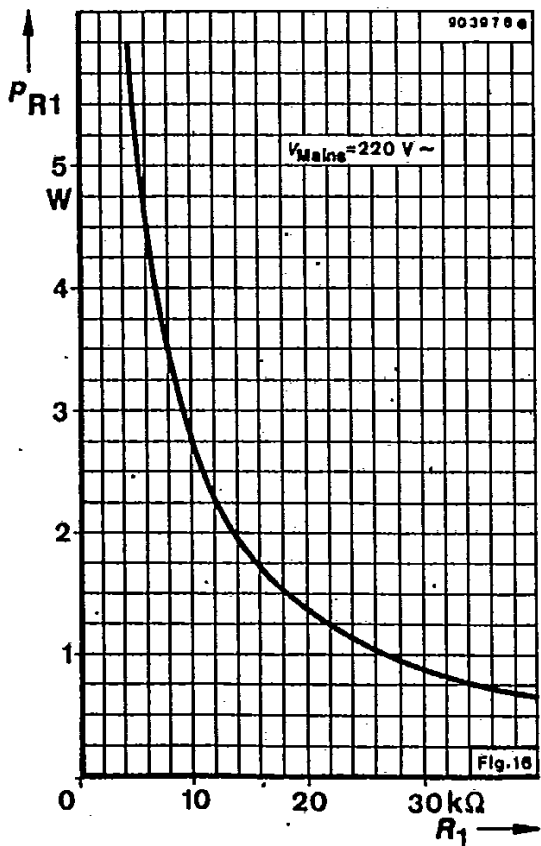
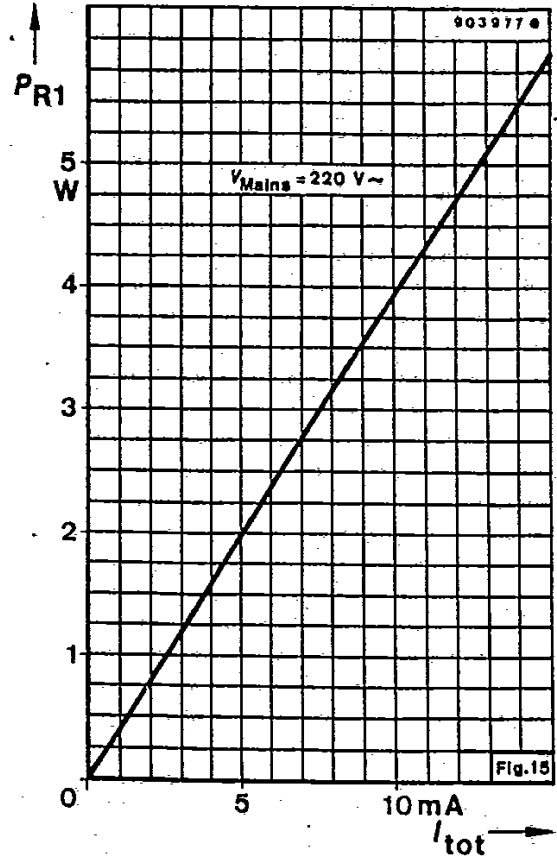
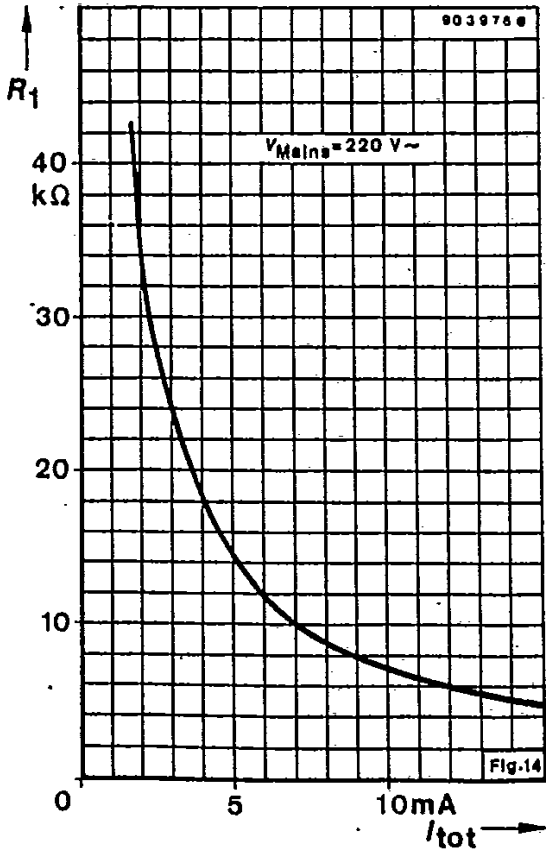



U 263 B1 · U 263 B2

TELEFUNKEN ELECTRONIC

T-65-09

ΔV_2 mV	5	10	20	30	40	50	60	70
V_{TS} V	12	6.8	3.3	1.8	1.5	1.0	0.91	0.82
R_6 M Ω	12	6.8	3.3	1.8	1.5	1.0	0.91	0.82
3.2	4.3	6.8	6.2	3.0	4.7	2.0	3.6	3.9
3.0	3.6	5.6	5.1	2.2	3.9	1.5	2.7	3.3
2.8	3.0	5.1	4.7	1.8	3.3	1.0	2.2	2.79
2.6	2.4	4.3	3.9	1.3	3.0	0.62	1.8	2.2
2.4	2.2	3.9	3.9	1.2	2.7	0.43	1.6	2.0
2.2	2.2	3.9	3.6	1.1	2.4	0.93	1.5	1.8

Table 2: Determination of the resistors R_6 in M Ω and R_7 in k Ω for a 2-point controller (U 263 B2) with hysteresis

Determination of component values

Fig. 10: $t_p = f(I_L, P)$

$$t_p = \frac{3}{4\pi f} \cdot \arcsin \left(\frac{I_L \cdot V_{RMS}}{P\sqrt{2}} \right)$$

- t_p = Pulse width
- I_L = Latching current
- P = Power rating
- V_{RMS} = Effective value of mains voltage

Fig. 11: $R_2 = f(t_p)$

$$R_2 = \frac{V \cdot \sin \left(\frac{\omega t_p \cdot 2}{3} \right) - 0.64}{25 \mu A} = -1.4 \text{ k}\Omega$$

- V = Peak value of mains voltage

Fig. 12: $R_G = f(I_G)$

$$R_G = \frac{V_{Smin} - V_G - 1.3 V}{I_G} - 65 \Omega$$

- V_{Smin} = Supply voltage, minimum
- V_G = Gate voltage of Triac
- I_G = Gate current of Triac

$$R_G = \frac{3.4 V}{I_G} - 65 \Omega$$

Fig. 13: $I_p = f(I_G, t_p)$

- I_p = Average current value of I_G

$$I_p = 2 \cdot \frac{I_G \cdot t_p}{10 \text{ ms}}$$

Fig. 14: $R_1 = f(I_{tot})$

$$R_1 = 0.85 \frac{V_{Mmin} - V_{Smax}}{2 I_{tot}}$$

- R_1 = Series resistor
- I_{tot} = Total current across R_1
- V_{Mmin} = Mains voltage, minimum
- $V_{Smax} = 7.4 V$
- I_{Smax} = Current consumption of IC
- I_p = Average current of trigger pulses
- I_x = Total current of peripheral components nominal value voltage source

$$I_{tot} = I_{Smax} + I_p + I_x$$

$$I_{Smax} = 1.8 \text{ mA}$$

I_p from Fig. 13 and Fig. 20

$$I_x \approx 0 \mu A$$



T-65-09

U 263 B1 · U 263 B2

TELEFUNKEN ELECTRONIC

Fig. 15 and Fig. 16: $P_{R1} = f(I_{tot})$

$$P_{R1} \approx \frac{(V_{Max} - V_{Smin})^2}{2R_1}$$

Fig. 17: $V_{TS} = f(T_x)$

$$V_{TS} = V_{T25} + T_x \cdot \Delta T$$

Fig. 18:

see Fig. 7 $R_7 = f(\Delta V)$ or $f(\Delta T)$

$$R_7 = \frac{R_8 + 32 \text{ k}\Omega}{\frac{V_D}{\Delta V} - 1} - \frac{V_{TS}}{V_S} \cdot 150 \text{ k}\Omega \left(1 - \frac{V_{TS}}{V_S}\right)$$

Fig. 19: $R_4 = f(V_{TS} \cdot V_S)$

$$R_4 = \frac{V_{TS}}{V_S} \cdot 150 \text{ k}\Omega$$

Fig. 20: $t_{pmax} = f(R_2)$

$$t_{pmax} = \frac{3}{2\omega} \cdot \arcsin \cdot \left[\frac{(1.4 \text{ k}\Omega + R_2) 83 \mu\text{A} + 0.64}{\hat{V}} \right]$$

P_{R1} = Power dissipation in R_1

V_{Smin} = 5.7 V

T_x = Nominal temperature

V_{TS} = Nominal temperature voltage

ΔT = $(T_x - 25^\circ\text{C})$

V_S = Supply voltage

ΔT = Temperature hysteresis

V_{TS} = 2.8 V

(symmetr. phasing of proportional term)

V_{D1} = $1.7 - V_{TS}$

V_{D2} = $3.9 - V_{TS}$

$$|V_{D1}| > |V_{D2}| \rightarrow |V_D| = |V_{D1}|$$

$$|V_{D2}| > |V_{D1}| \rightarrow |V_D| = |V_{D2}|$$

$R_8 = 4.7 \text{ M}\Omega$

$$R_4 + R_6 = 150 \text{ k}\Omega$$



TELEFUNKEN ELECTRONIC

U 263 B1 · U 263 B2

T-65-09

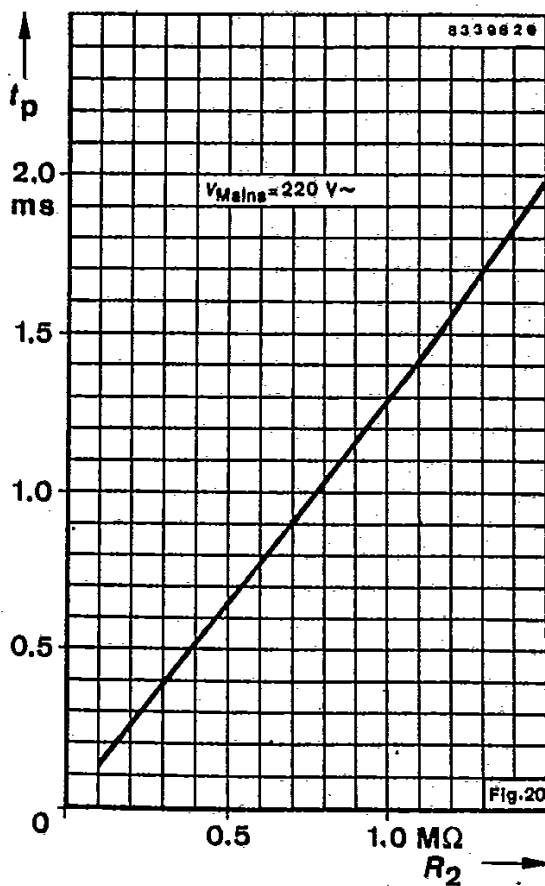
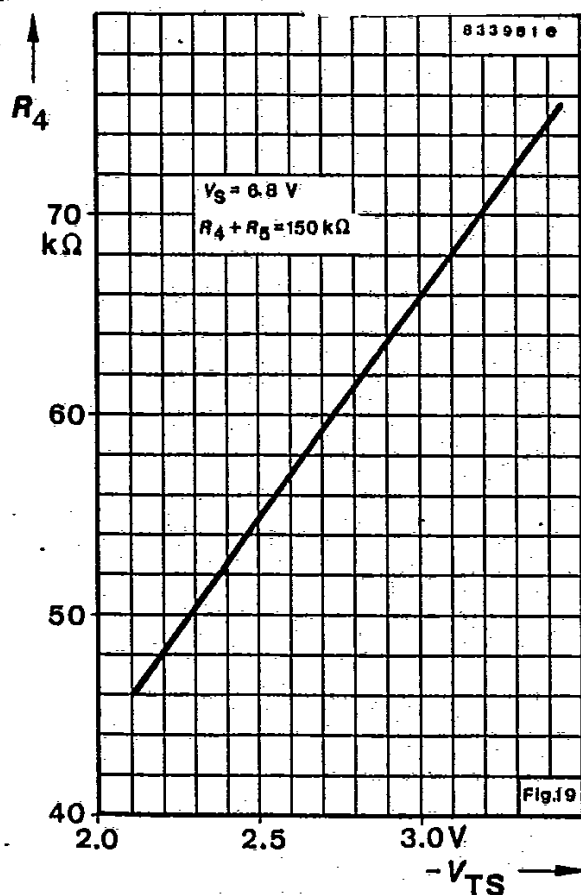
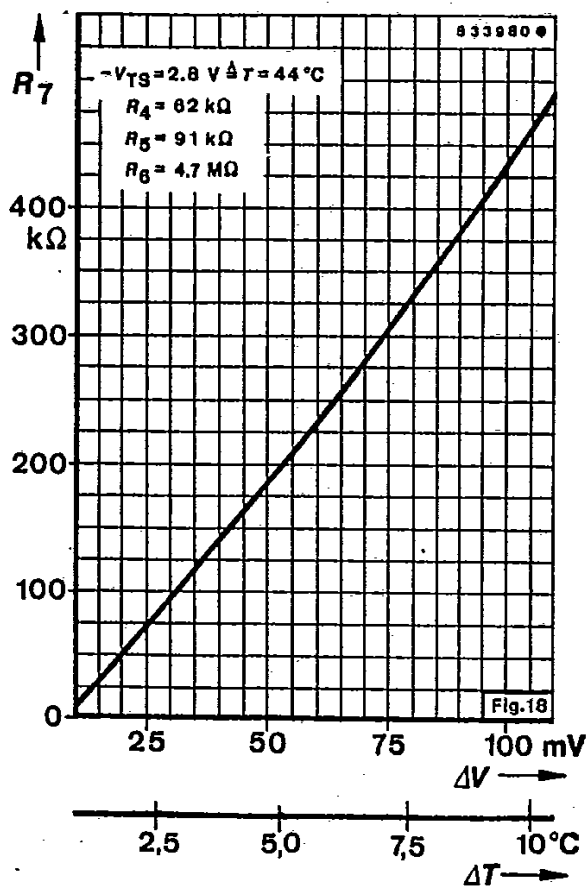



U 263 B1 · U 263 B2

T-65-09

TELEFUNKEN ELECTRONIC

Application Example with U 263 B1

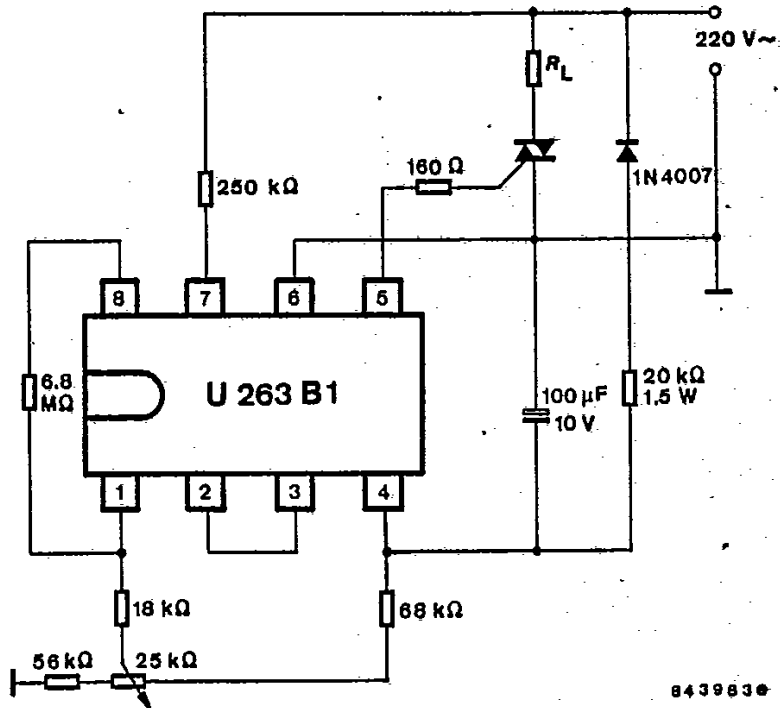

Fig. 21 Two point temperature controller with superimposed proportional behaviour and internal temperature sensor for a temperature range of 10...30 °C and a hysteresis (dead zone) of ± 1 °C

Application examples with U 263 B2

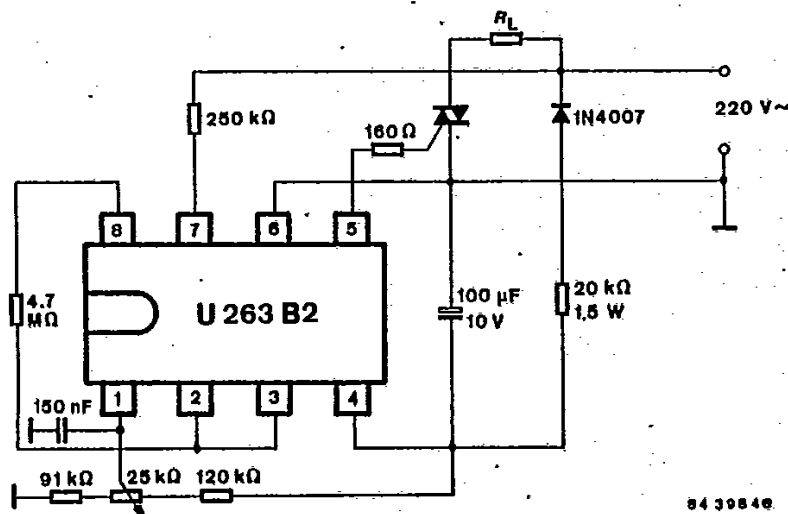

Fig. 22 Two-point temperature controller with internal temperature sensor for a temperature range of 10...30 °C and hysteresis of ± 1 °C



U 263 B1 · U 263 B2

TELEFUNKEN ELECTRONIC

T-65-09

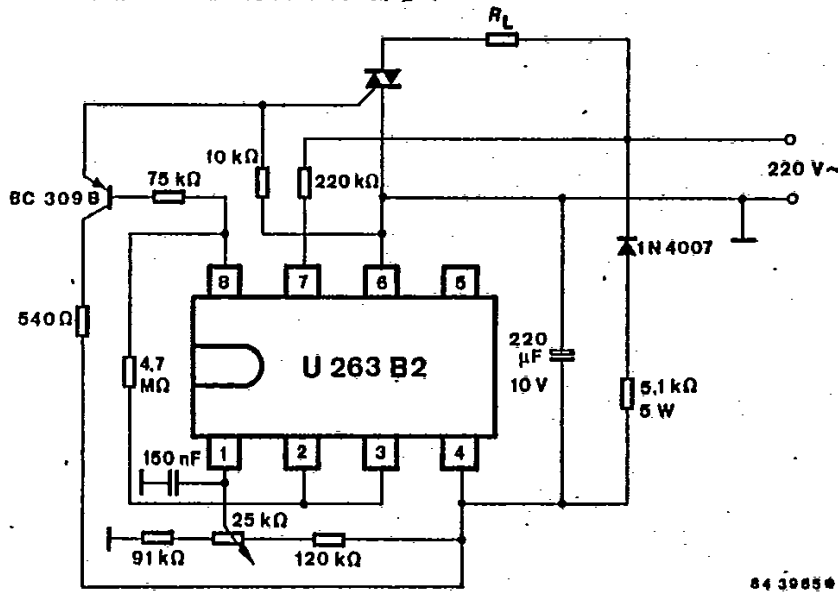

Fig. 23 Two-point room temperature controller with internal temperature sensor for a temperature range of 15...30 °C hysteresis for resistive or inductive load



U 263 B1 · U 263 B2

TELEFUNKEN ELECTRONIC

T-65-09

Dimensions in mm

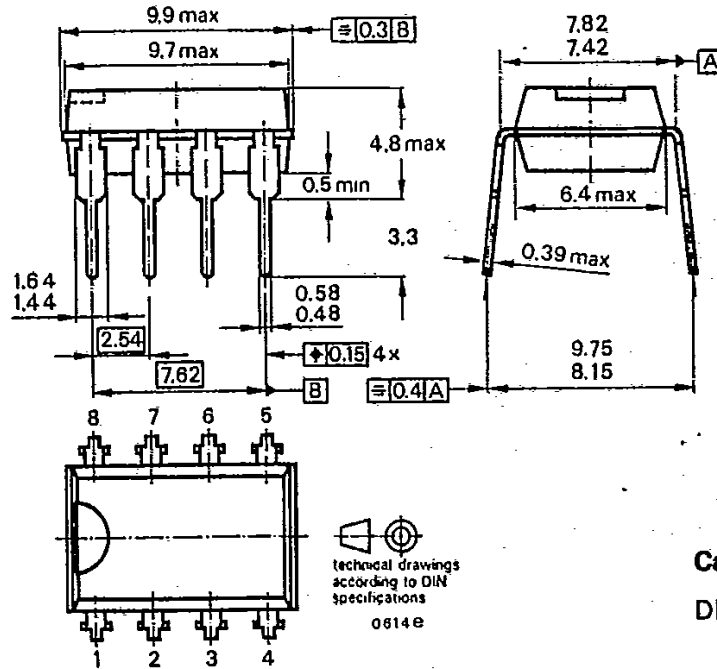

Case:
DIP 8