

STRUCTURE	Silicon Monolithic Integrated Circuit
NAME OF PRODUCT	DC-AC Inverter Control IC
TYPE	<b>BD9890FV</b>
FUNCTION	<ul style="list-style-type: none"> <li>• 2ch control with Push-Pull</li> <li>• Lamp current and voltage sense feed back control</li> <li>• Sequencing easily achieved with Soft Start Control</li> <li>• Short circuit protection with Timer Latch</li> <li>• Under Voltage Lock Out</li> <li>• Short circuit protection with over voltage</li> <li>• Mode-selectable the operating or stand-by mode by stand-by pin</li> <li>• Synchronous operating the other BD9890F or BD9890FV IC's</li> <li>• BURST mode controlled by PWM and DC input</li> <li>• 2ch in-phase in BURST mode</li> </ul>

### ○Absolute Maximum Ratings (Ta = 25°C)

Parameter	Symbol	Limits	Unit
Supply Voltage	Vcc	15	V
Operating Temperature Range	Topr	-40~+90	°C
Storage Temperature Range	Tstg	-55~+125	°C
Power Dissipation	Pd	600* <sup>1</sup> (BD9890F)	mW
		850* <sup>2</sup> (BD9890FV)	
Maximum Junction Temperature	Tjmax	+125	°C

\*<sup>1</sup>Pd derate at 6.0mW/°C for temperature above Ta = 25°C (When mounted on a PCB 70.0mm×70.0mm×1.6mm)

\*<sup>2</sup>Pd derate at 8.5mW/°C for temperature above Ta = 25°C (When mounted on a PCB 70.0mm×70.0mm×1.6mm)

### ○Recommended operating condition

Parameter	Symbol	Limits	Unit
Supply voltage	VCC	5.0~14.0	V
CT oscillation frequency	fCT	20~150	kHz
BCT oscillation frequency	fBCT	0.05~0.50	kHz

#### Status of this document

The Japanese version of this document is the official specification.

Please use the translation version of this document as a reference to expedite understanding of the official version.

If there are any uncertainty in translation version of this document, official version takes priority.

○Electric Characteristics (Ta=25°C, VCC=7V)

Parameter	Symbol	Limits			Unit	Conditions
		MIN.	TYP.	MAX.		
((WHOLE DEVICE))						
Operating current	Icc1	—	11.0	17.0	mA	CT=0.5V
Stand-by current	Icc2	—	2	10	μA	
((OVER VOLTAGE DETECT))						
FB over voltage detect voltage	Vovf	2.20	2.40	2.60	V	
((STAND BY CONTROL))						
Stand-by voltage H	VstH	1.6	—	VCC	V	System O N
Stand-by voltage L	VstL	-0.3	—	0.8	V	System O F F
Stand-by hysteresis	ΔVst	0.08	0.18	0.28	V	
((TIMER LATCH))						
Timer Latch voltage	Vcp	1.9	2.0	2.1	V	
Timer Latch current	Icp	0.5	1.0	1.5	μA	
((BURST MODE))						
BOSC Max voltage	VburH	1.94	2.0	2.06	V	fBCT=0.2kHz
BOSC Min Voltage	VburL	0.4	0.5	0.6	V	fBCT=0.2kHz
BOSC constant current	IBCT	1.35/BRT	1.5/BRT	1.65/BRT	A	
BOSC frequency	fBOSC	266	280	294	Hz	BRT=33kΩ、BCT=0.050μF
((OSC BLOCK))						
OSC constant current	ICT	1.35/RT	1.5/RT	1.65/RT	A	
OSC Max voltage	VosCH	1.8	2.0	2.2	V	fCT=60kHz
OSC Min voltage	VosCL	0.3	0.5	0.7	V	fCT=60kHz
MAX DUTY	MAXDUTY	44	46.5	49	%	fCT=60kHz
Soft start current	Iss	1.0	2.0	3.0	μA	
IS COMP detect Voltage	Visc	0.45	0.50	0.55	V	
SS COMP detect voltage	Vss	2.0	2.2	2.4	V	
SRT ON resistance	RSRT	—	200	400	Ω	
((UVLO BLOCK))						
Operating voltage	VuvloH	4.100	4.300	4.500	V	
Shut down voltage	VuvloL	3.900	4.100	4.300	V	
Operating voltage (External UVLO)	Vuvlo1	2.160	2.220	2.280	V	
Lock out voltage (External UVLO)	Vuvlo2	2.242	2.315	2.388	V	
Hysteresis width	ΔVuvlo	0.068	0.095	0.122	V	
((REG BLOCK))						
REG output voltage	VREG	3.038	3.100	3.162	V	
REG source current	I <sub>REG</sub>	5.0	—	—	mA	
VREF voltage	Vref1	1.225	1.250	1.275	V	VREF=OPEN
VREF input voltage range	Vref2	0.60	—	1.50	V	VREF applying voltage
((FEED BACK BLOCK))						
IS threshold voltage 1	Vis1	1.225	1.250	1.275	V	VREF=OPEN
IS threshold voltage 2	Vis2	—	Vref2	—	V	VREF applying voltage
VS threshold voltage	Vvs	1.220	1.250	1.280	V	
IS source current 1	Iis1	—	—	1.5	μA	DUTY=2.0V
IS source current 2	Iis2	13.0	20.0	27.0	μA	DUTY=0V、IS=0.5V
VS source current	Ivs	—	—	1.0	μA	
((OUTPUT BLOCK))						
NAch output voltage H	VoutNAH	VCC-0.3	VCC-0.1	—	V	
NBch output voltage H	VoutNBH	VCC-0.3	VCC-0.1	—	V	
NAch output voltage L	VoutNAL	—	0.1	0.3	V	
NBch output voltage L	VoutNBL	—	0.1	0.3	V	
NAch output sink resistance	RsinkNA	—	5	10	Ω	I <sub>sink</sub> = 10mA
NAch output source resistance	RsourceNA	—	8	16	Ω	I <sub>source</sub> = 10mA
NBch output sink resistance	RsinkNB	—	5	10	Ω	I <sub>sink</sub> = 10mA
NBch output source resistance	RsourceNB	—	8	16	Ω	I <sub>source</sub> = 10mA
Drive output frequency	fOUT	58.5	60.0	61.5	KHz	RT=18kΩ、CT=400pF
((COMP BLOCK))						
Under voltage detect	VCOMPL	0.620	0.640	0.660	V	
((PROTECT CLOCK))						
Normal output voltage	VPH	2.9	3.1	3.3	V	
Protect output voltage	VPL	—	—	0.5	V	

(This product is not designed to be radiation-resistant.)

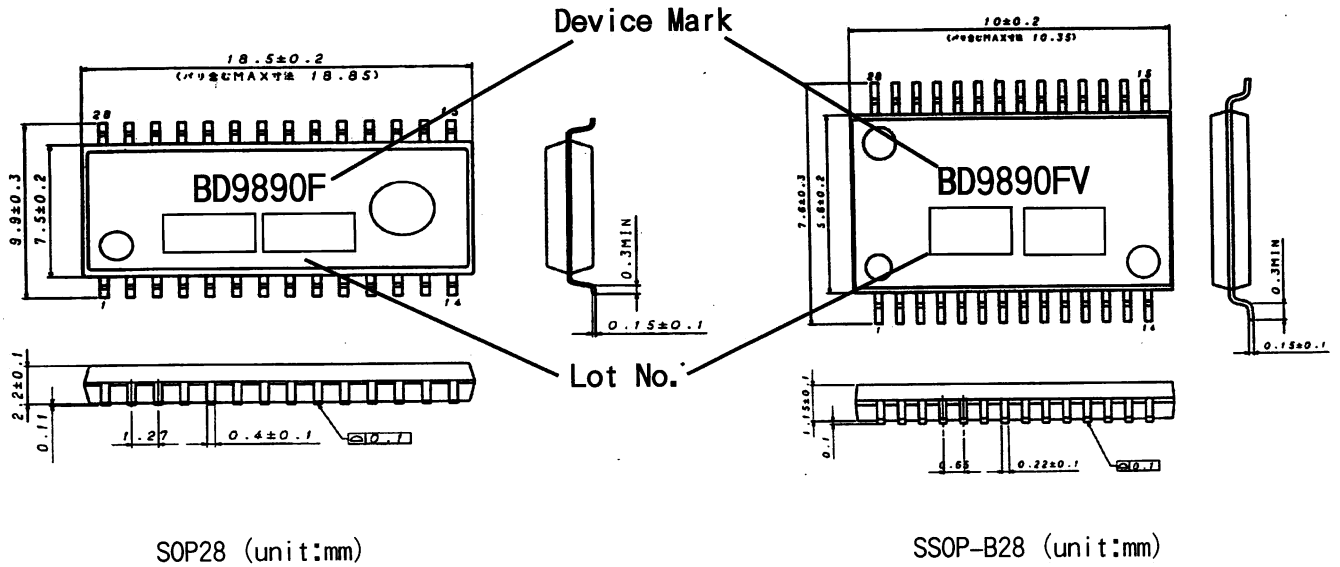

○Block Diagram

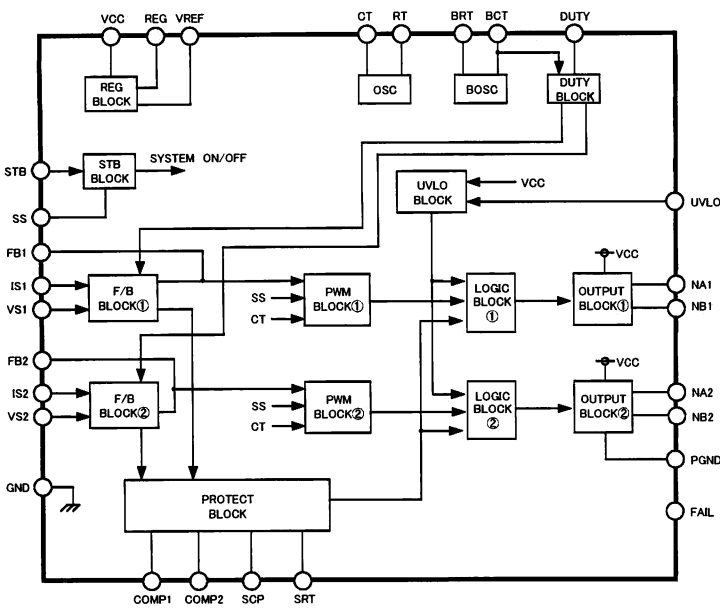

○Pin Description

Pin No.	Pin Name	Function
1	DUTY	Control PWM mode and BURST mode
2	BRT	External resistor from BRT to GND for adjusting the BURST triangle oscillator
3	BCT	External capacitor from BCT to GND for adjusting the BURST triangle oscillator
4	RT	External resistor from SRT to RT for adjusting the triangle oscillator
5	SRT	External resistor from SRT to RT for adjusting the triangle oscillator
6	CT	External capacitor from CT to GND for adjusting the triangle oscillator
7	GND	GROUND
8	FB1	Error amplifier output①
9	IS1	Error amplifier input①
10	VS1	Error amplifier input②
11	FB2	Error amplifier output②
12	IS2	Error amplifier input③
13	VS2	Error amplifier input④
14	VREF	Reference voltage
15	FAIL	Protect clock output
16	STB	Stand-by switch
17	COMP1	Under voltage detect for 1ch
18	COMP2	Under voltage detect for 2ch
19	UVLO	External Under Voltage Lock OUT
20	REG	Internal regulator output
21	SS	External capacitor from SS to GND for Soft Start Control
22	SCP	External capacitor from SCP to GND for Timer Latch
23	NA2	FET driver for 2ch
24	NB2	FET driver for 2ch
25	PGND	Ground for FET drivers
26	NB1	FET driver for 1ch
27	NA1	FET driver for 1ch
28	Vcc	Supply voltage input

○NOTE FOR USE

1. When designing the external circuit, including adequate margins for variation between external devices and IC. Use adequate margins for steady state and transient characteristics.
2. The circuit functionality is guaranteed within of ambient temperature operation range as long as it is within recommended operating range. The standard electrical characteristic values cannot be guaranteed at other voltages in the operating ranges, however the variation will be small.
3. Mounting failures, such as misdirection or miscounts, may harm the device.
4. A strong electromagnetic field may cause the IC to malfunction.
5. The GND pin should be the location within  $\pm 0.3V$  compared with the PGND pin.
6. BD9890F and BD9890FV incorporate a built-in thermal shutdown circuit (TSD circuit). The thermal shutdown circuit (TSD circuit) is designed only to shut the IC off to prevent runaway thermal operation. It is not designed to protect the IC or guarantee its operation of the thermal shutdown circuit is assumed.
7. Absolute maximum ratings are those values that, if exceeded, may cause the life of a device to become significantly shortened. Moreover, the exact failure mode caused by short or open is not defined. Physical countermeasures, such as a fuse, need to be considered when using a device beyond its maximum ratings.
8. About the external FET, the parasitic Capacitor may cause the gate voltage to change, when the drain voltage is switching. Make sure to leave adequate margin for this IC variation.
9. On operating Slow Start Control (SS is less than 2.2V), It does not operate Timer Latch.
10. By STB voltage, BD9890F and BD9890FV are changed to 2 states. Therefore, do not input STB pin voltage between one state and the other state (0.8~1.6).
11. The pin connected a connector need to connect to the resistor for electrical surge destruction. This IC is a monolithic IC which (as shown is Fig-1) has P<sup>+</sup> substrate and between the various pins. A P-N junction is formed from this P layer of each pin. For example, the relation between each potential is as follows,

- (When GND > PinB and GND > PinA, the P-N junction operates as a parasitic diode.)
- (When PinB > GND > PinA, the P-N junction operates as a parasitic transistor.)

Parasitic diodes can occur inevitably in the structure of the IC. The operation of parasitic diodes can result in mutual interference among circuits as well as operation faults and physical damage. Accordingly you must not use methods by which parasitic diodes operate, such as applying a voltage that is lower than the GND (P substrate) voltage to an input pin.

12. This IC is a monolithic IC which (as shown is Fig-1)has P<sup>+</sup> substrate and between the various pins. A P-N junction is formed from this P layer of each pin. For example, the relation between each potential is as follows,

- (When GND > PinB and GND > PinA, the P-N junction operates as a parasitic diode.)
- (When PinB > GND > PinA, the P-N junction operates as a parasitic transistor.)

Parasitic diodes can occur inevitably in the structure of the IC. The operation of parasitic diodes can result in mutual interference among circuits as well as operation faults and physical damage. Accordingly you must not use methods by which parasitic diodes operate, such as applying a voltage that is lower than the GND (P substrate) voltage to an input pin.

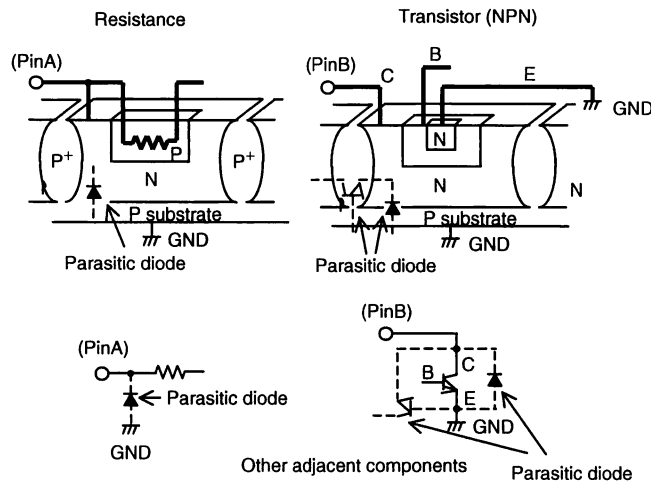

Fig-1 Simplified structure of a Bipolar IC

### Notes

- No technical content pages of this document may be reproduced in any form or transmitted by any means without prior permission of ROHM CO.,LTD.
- The contents described herein are subject to change without notice. The specifications for the product described in this document are for reference only. Upon actual use, therefore, please request that specifications to be separately delivered.
- Application circuit diagrams and circuit constants contained herein are shown as examples of standard use and operation. Please pay careful attention to the peripheral conditions when designing circuits and deciding upon circuit constants in the set.
- Any data, including, but not limited to application circuit diagrams information, described herein are intended only as illustrations of such devices and not as the specifications for such devices. ROHM CO.,LTD. disclaims any warranty that any use of such devices shall be free from infringement of any third party's intellectual property rights or other proprietary rights, and further, assumes no liability of whatsoever nature in the event of any such infringement, or arising from or connected with or related to the use of such devices.
- Upon the sale of any such devices, other than for buyer's right to use such devices itself, resell or otherwise dispose of the same, no express or implied right or license to practice or commercially exploit any intellectual property rights or other proprietary rights owned or controlled by
- ROHM CO., LTD. is granted to any such buyer.
- Products listed in this document are no antiradiation design.

The products listed in this document are designed to be used with ordinary electronic equipment or devices (such as audio visual equipment, office-automation equipment, communications devices, electrical appliances and electronic toys).

Should you intend to use these products with equipment or devices which require an extremely high level of reliability and the malfunction of which would directly endanger human life (such as medical instruments, transportation equipment, aerospace machinery, nuclear-reactor controllers, fuel controllers and other safety devices), please be sure to consult with our sales representative in advance.

#### About Export Control Order in Japan

Products described herein are the objects of controlled goods in Annex 1 (Item 16) of Export Trade Control Order in Japan.

In case of export from Japan, please confirm if it applies to "objective" criteria or an "informed" (by MITI clause) on the basis of "catch all controls for Non-Proliferation of Weapons of Mass Destruction.

Thank you for your accessing to ROHM product informations.  
More detail product informations and catalogs are available,  
please contact your nearest sales office.

Please contact our sales offices for details ;

U.S.A / San Diego	TEL : +1(858)625-3630	FAX : +1(858)625-3670
Atlanta	TEL : +1(770)754-5972	FAX : +1(770)754-0691
Dallas	TEL : +1(972)312-8818	FAX : +1(972)312-0330
Germany / Dusseldorf	TEL : +49(2154)9210	FAX : +49(2154)921400
United Kingdom / London	TEL : +44(1)908-282-666	FAX : +44(1)908-282-528
France / Paris	TEL : +33(0)1 56 97 30 60	FAX : +33(0) 1 56 97 30 80
China / Hong Kong	TEL : +852(2)740-6262	FAX : +852(2)375-8971
Shanghai	TEL : +86(21)6279-2727	FAX : +86(21)6247-2066
Dilian	TEL : +86(411)8230-8549	FAX : +86(411)8230-8537
Beijing	TEL : +86(10)8525-2483	FAX : +86(10)8525-2489
Taiwan / Taipei	TEL : +866(2)2500-6956	FAX : +866(2)2503-2869
Korea / Seoul	TEL : +82(2)8182-700	FAX : +82(2)8182-715
Singapore	TEL : +65-6332-2322	FAX : +65-6332-5662
Malaysia / Kuala Lumpur	TEL : +60(3)7958-8355	FAX : +60(3)7958-8377
Philippines / Manila	TEL : +63(2)807-6872	FAX : +63(2)809-1422
Thailand / Bangkok	TEL : +66(2)254-4890	FAX : +66(2)256-6334

Japan /  
(Internal Sales)

Tokyo	2-1-1, Yaesu, Chuo-ku, Tokyo 104-0082	TEL : +81(3)5203-0321	FAX : +81(3)5203-0300
Yokohama	2-4-8, Shin Yokohama, Kohoku-ku, Yokohama, Kanagawa 222-8575	TEL : +81(45)476-2131	FAX : +81(45)476-2128
Nagoya	Dainagayo Building 9F 3-28-12, Meieki, Nakamura-ku, Nagoya, Aichi 450-0002	TEL : +81(52)581-8521	FAX : +81(52)561-2173
Kyoto	579-32 Higashi Shiokouji-cho, Karasuma Nishi-iru, Shiokoujidori, Shimogyo-ku, Kyoto 600-8216	TEL : +81(75)311-2121	FAX : +81(75)314-6559

(Contact address for overseas customers in Japan)

Yokohama	TEL : +81(45)476-9270	FAX : +81(045)476-9271
----------	-----------------------	------------------------