

**DESCRIPTION**

The LX5121 Plug and Play UltraMAX™ terminator represents next-generation technology for SCSI termination applications. The low-voltage BiCMOS architecture employed in its design offers superior performance to older passive and active techniques.

Linfinity's architecture employs high-speed adaptive elements for each channel, providing the fastest response possible. The channel bandwidth is typically 35MHz. The LX5121 compares favorably to older linear regulator approaches whose bandwidths are dominated by the output compensation capacitor and are limited to the 500KHz bandwidth region (see further discussion in the Functional Description section). Linfinity's architecture also eliminates the output compensation capacitor typical in earlier terminator designs. Each is approved for use with SCSI-1,-2,-3, ULTRA and beyond — providing the highest performance alternative available today.

Another key improvement of LX5121 products lies in their ability to ensure reliable, error-free communications even in systems which do not necessarily adhere to recommended SCSI hardware design guidelines, such as the use of improper cable lengths and imped-

ances. Frequently, this situation is not controlled by the peripheral or host designer and, when problems occur, they are the first to be made aware of these problems. The LX5121 architecture is much more tolerant of marginal system integrations.

Recognizing the needs of portable and configurable peripherals, the LX5121 has a TTL compatible sleep/disable mode. Typically, quiescent current is less than 150µA in this mode.

Reduced component count is also inherent in the LX5121 architecture. Traditional termination techniques require large stabilization and transient protection capacitors of up to 20µF in value and size. The LX5121 architecture does not require these components, allowing all the cost savings associated with inventory, board space, assembly, reliability, and component costs.

The LX5121 has multiple disables for full Plug and Play SCSI capability for Host Bus Adapters with 3 SCSI connectors. It also splits the upper 9 termination lines for mixing 16-bit (wide) and 8-bit (narrow) buses with minimal board trace capacitance.

**KEY FEATURES**

- Ultra-Fast Response For Fast-20 SCSI Applications
- Plug And Play SCSI For Host Bus Adapters With 3 SCSI Connectors
- Split Disconnect For Mixing 16-Bit (Wide) Or 8-Bit (Narrow) Buses
- 35mhz Channel Bandwidth
- Sleep-Mode Current Less Than 150µA
- Hot-Swap Compatible
- $\bar{N}O$  External Compensation Capacitors
- Compatible With Active Negation Drivers
- Superior Pin-for-Pin Replacement For The UCC5621

**NOTE:** For current data & package dimensions, visit our web site: <http://www.linfinity.com>.

**PRODUCT HIGHLIGHT**

RECEIVING WAVEFORM - 20MHZ

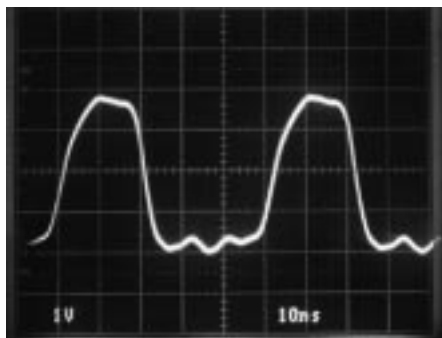

DRIVING WAVEFORM - 20MHZ

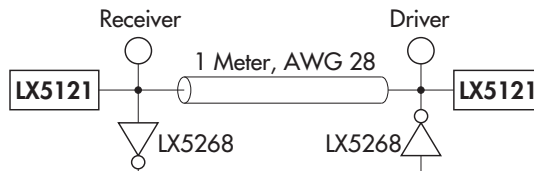
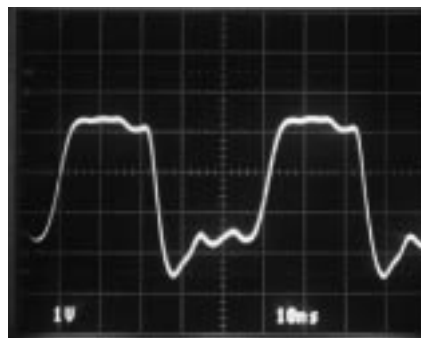

**NOTE:**  
For An In-Depth Discussion On Applying SCSI, Request Linfinity Application Note: "Understanding The Single-Ended SCSI Bus"

**PACKAGE ORDER INFO**

T <sub>J</sub> (°C)	DB Plastic SSOP 44-pin
0 to 125	LX5121CDB

Note: Available in Tape & Reel.  
Append the letter "T" to part number. (i.e. LX5121CDBT)

## ULTRA 27-LINE, PLUG AND PLAY SCSI TERMINATOR

### PRODUCTION DATA SHEET

#### ABSOLUTE MAXIMUM RATINGS (Note 1)

TermPwr Voltage .....	7V
Continuous Output Voltage Range .....	0 to 5.5V
Continuous Disable Voltage Range .....	0 to 5.5V
Operating Junction Temperature	
Plastic (DB Packages) .....	150°C
Storage Temperature Range .....	-65°C to +150°C
Solder Temperature (Soldering, 10 seconds) .....	300°C

Note 1. Exceeding these ratings could cause damage to the device.

#### THERMAL DATA

##### DB PACKAGE:

<b>THERMAL RESISTANCE-JUNCTION TO AMBIENT, <math>\theta_{JA}</math></b>	<b>50°C/W</b>
---	---------------

Junction Temperature Calculation:  $T_J = T_A + (P_D \times \theta_{JA})$ .

The  $\theta_{JA}$  numbers are guidelines for the thermal performance of the device/pc-board system. All of the above assume no ambient airflow.

#### PACKAGE PIN OUTS

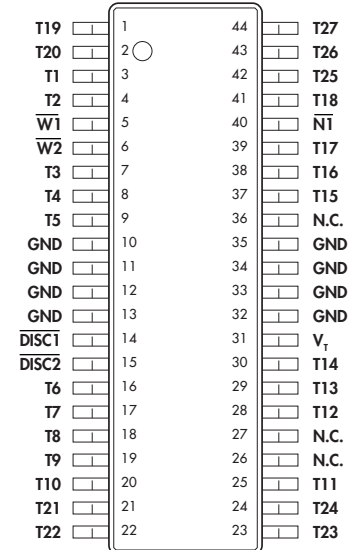

DB PACKAGE  
(Top View)

#### RECOMMENDED OPERATING CONDITIONS (Note 2)

Parameter	Symbol	Recommended Operating Conditions			Units
		Min.	Typ.	Max.	
Termination Voltage	$V_{TERM}$	4.0		5.5	V
High Level Disable Input Voltage	$V_{IH}$	2		$V_{TERM}$	V
Low Level Disable Input Voltage	$V_{IL}$	0		0.8	V
Operating Virtual Junction Temperature Range					
LX5121C		0		125	°C

Note 2. Range over which the device is functional.

#### ELECTRICAL CHARACTERISTICS

**Term Power = 4.75V unless otherwise specified.** Unless otherwise specified, these specifications apply at the recommended operating ambient temperature of  $T_A = 25^\circ\text{C}$ . Low duty cycle pulse testing techniques are used which maintains junction and case temperatures equal to the ambient temperature.

Parameter	Symbol	Test Conditions	LX5121			Units
			Min.	Typ.	Max.	
Output High Voltage	$V_{OUT}$		2.65	2.85		V
TermPwr Supply Current	$I_{CC}$	All data lines = open		12	20	mA
		All data lines = 0.2V		635	670	mA
		Disable Pins 1 & 2 < 0.8V		50	150	$\mu\text{A}$
Output Current	$I_{OUT}$	$V_{OUT} = 0.2\text{V}$	-20	-22	-24	mA
Disable Input Current	$I_{IN}$	$\overline{DISC1} = 0\text{V}$			-10	$\mu\text{A}$
		$\overline{DISC2} = 0\text{V}$			-10	$\mu\text{A}$
Output Leakage Current		$\overline{DISC1}$ and $\overline{DISC2} = < 0.8\text{V}, V_O = 0.2\text{V}$			1	$\mu\text{A}$
Channel Bandwidth	BW			35		MHz
Termination Sink Current, per Channel	$I_{SINK}$	$V_{OUT} = 4\text{V}$	7			mA

ULTRA 27-LINE, PLUG AND PLAY SCSI TERMINATOR

PRODUCTION DATA SHEET

BLOCK DIAGRAM

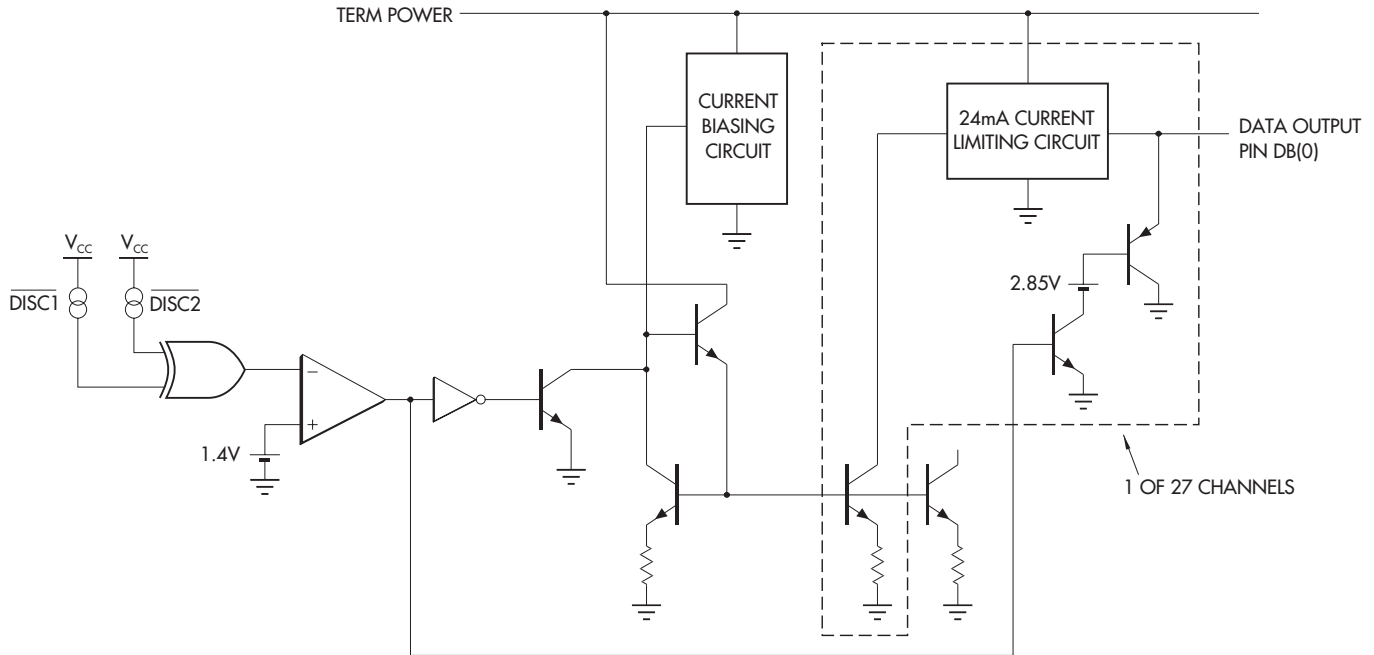

FUNCTIONAL DESCRIPTION

Cable transmission theory suggests that in order to optimize signal speed and quality, the termination should act both as an ideal voltage reference when the line is released (de-asserted) and as an ideal current source when the line is active (asserted). Common active terminators, which consist of Linear Regulators in series with resistors (typically 110Ω), are a compromise. As the line voltage increases, the amount of current decreases linearly by the equation  $V = I * R$ . The UltraMAX LX5121, with its unique new architecture, applies the maximum amount of current regardless of line voltage until the termination high threshold (2.85V) is reached.

Acting as a near ideal line terminator, the LX5121 closely

POWER UP / POWER DOWN FUNCTION TABLE

DISC1	DISC2	W1	W2	N1	T1-T18	T19-T27
H	L	DC	DC	DC	Enabled	Disabled
L	H	DC	DC	DC	Disabled	Enabled
L	L	DC	DC	DC	Disabled	Disabled
H	H	H	H	H	Enabled	Enabled
H	H	H	H	L	Enabled	Enabled
H	H	H	L	H	Enabled	Enabled
H	H	H	L	L	Disabled	Enabled
H	H	L	H	H	Enabled	Enabled
H	H	L	H	L	Disabled	Enabled
H	H	L	L	H	Disabled	Disabled
H	H	L	L	L	Disabled	Disabled

reproduces the optimum case when the device is enabled. To enable the device the DISC1 and DISC2 pins must be driven per the above table. During this mode of operation, quiescent current is 12mA and the device will respond to line demands by delivering 24mA on assertion and by imposing 2.85V on de-assertion. Disable mode places the device in a sleep state, where a meager 150µA of quiescent current is consumed.

Additionally, all outputs are in a Hi-Z (impedance) state. Sleep mode can be used for power conservation or to completely eliminate the terminator from the SCSI chain.

An additional feature of the LX5121 is its compatibility with active negation drivers.

**ULTRA 27-LINE, PLUG AND PLAY SCSI TERMINATOR**

**PRODUCTION DATA SHEET**

**PLUG AND PLAY SCSI DIAGRAM**

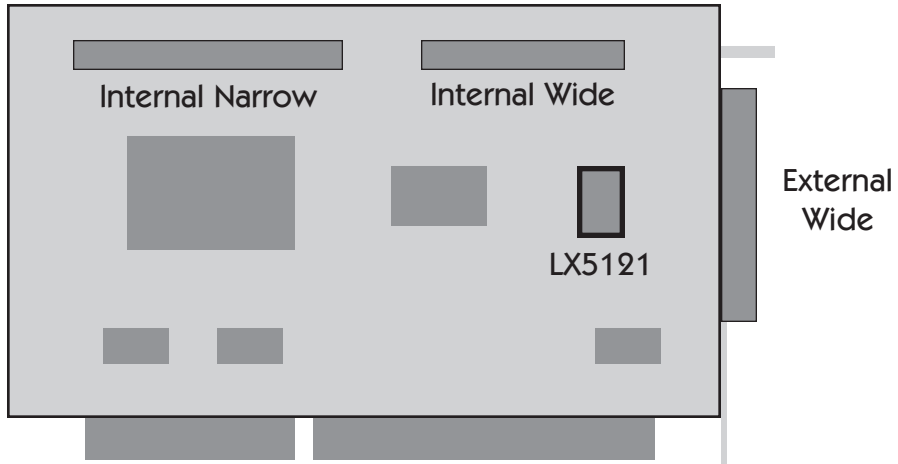

For Plug and Play SCSI auto-termination disabling, connect pin 50 of the External Wide SCSI connector to  $\overline{W1}$  of the LX5121, connect pin 50 of the Internal Wide SCSI connector to  $\overline{W2}$  of the LX5121, and connect pin 22 of the Internal Narrow connector to  $\overline{N1}$  of the LX5121.

UltraMAX is a trademark of Linfinity Microelectronics Inc.

PRODUCTION DATA - Information contained in this document is proprietary to Linfinity, and is current as of publication date. This document may not be modified in any way without the express written consent of Linfinity. Product processing does not necessarily include testing of all parameters. Linfinity reserves the right to change the configuration and performance of the product and to discontinue product at any time.

