

120 Amp Schottky Rectifier HS12230

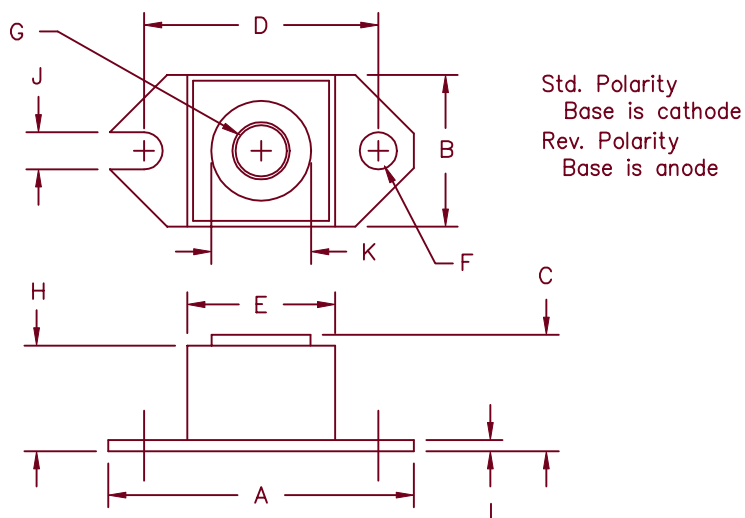

Dim.	Inches		Millimeter		Notes
	Minimum	Maximum	Minimum	Maximum	
A	1.52	1.56	38.61	39.62	
B	.725	.775	18.42	19.69	
C	.605	.625	15.37	15.88	
D	1.182	1.192	30.02	30.28	
E	.745	.755	18.92	19.18	Sq.
F	.152	.160	3.86	4.06	Dia.
G			1/4-20 UNC-2B		
H	.545	.555	13.84	14.10	
J	.156	.160	3.96	4.06	
K	.495	.505	12.57	12.83	Dia.
L	.120	.130	3.05	3.30	

HALF-PAK

Microsemi Catalog Number	Industry Part Number	Working Peak Reverse Voltage	Repetitive Peak Reverse Voltage
HS12230*	122NQ030	30V	30V

*Add Suffix R for Reverse Polarity

- Schottky Barrier Rectifier
- Guard Ring Protection
- Low Forward Voltage
- 150°C Junction Temperature
- V_{RRM} 30 Volts
- Reverse Energy Tested

Electrical Characteristics

Average forward current	$I_F(AV)$ 120 Amps	$T_C = 108^\circ C$, Square wave, $R_{\theta JC} = 0.4^\circ C/W$
Maximum surge current	I_{FSM} 2000 Amps	8.3ms, half sine, $T_J = 125^\circ C$
Maximum repetitive reverse current	$I_R(OV)$ 2 Amps	$f = 1$ KHZ, 1 $T_J = 25^\circ C$
Max peak forward voltage	V_{FM} 0.49 Volts	$I_{FM} = 120A$; $T_J = 125^\circ C^*$
Max peak forward voltage	V_{FM} 0.55 Volts	$I_{FM} = 120A$; $T_J = 25^\circ C^*$
Max peak reverse current	I_{RM} 2.0 Amp	V_{RRM} , $T_J = 125^\circ C^*$
Max peak reverse current	I_{RM} 5mA	V_{RRM} , $T_J = 25^\circ C$
Typical junction capacitance	C_J 5500pF	$V_R = 5.0V$, $T_J = 25^\circ C$, $f = 1MHz$

*Pulse test: Pulse width 300 μsec , Duty cycle 2%

Thermal and Mechanical Characteristics

Storage temp range	T_{STG}	$-55^\circ C$ to $175^\circ C$
Operating junction temp range	T_J	$-55^\circ C$ to $150^\circ C$
Max thermal resistance	$R_{\theta JC}$	$0.4^\circ C/W$ junction to case
Typical thermal resistance (greased)	$R_{\theta CS}$	$0.12^\circ C/W$ case to sink
Terminal Torque		35-40 inch pounds
Mounting Base Torque		20-25 inch pounds
Weight		1.1 ounces (32 grams) typical

7-23-01 Rev. 2

HS12230

Figure 1
Typical Forward Characteristics

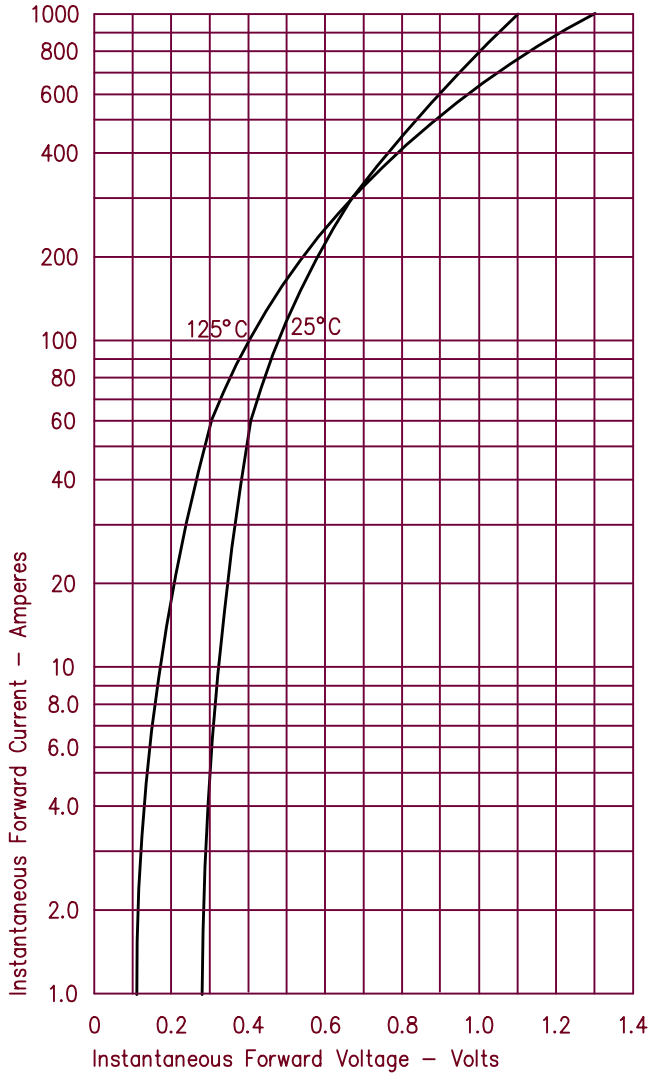

Figure 3
Typical Junction Capacitance

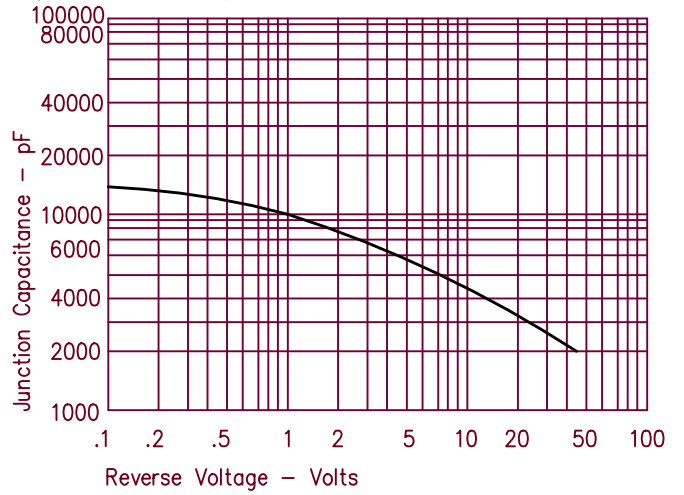

Figure 4
Forward Current Derating

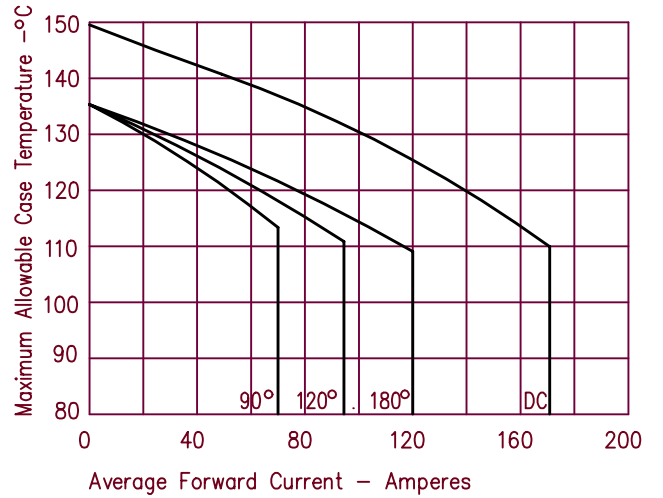

Figure 2
Typical Reverse Characteristics

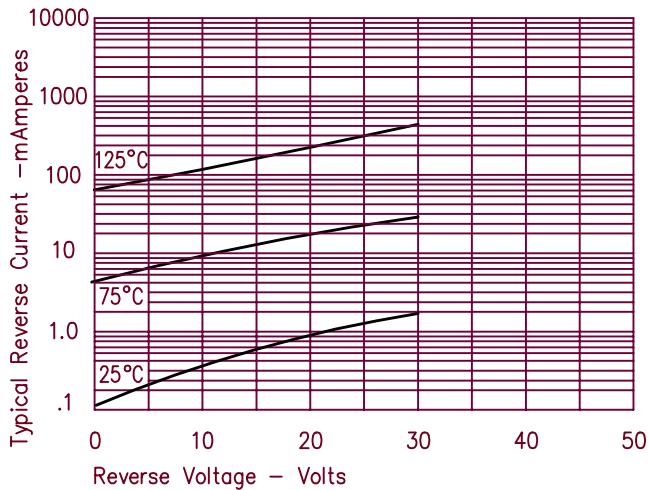

Figure 5
Maximum Forward Power Dissipation

