

# AZ Displays, Inc.

## 1. MECHANICAL DATA

(1) Product No.	AGM3224F
(2) Module Size	160.0 (W)mm x 109.0 (H)mm x 11.0 (D)mm
(3) Dot Size	0.33 (W)mm x 0.33 (H)mm
(4) Dot Pitch	0.36 (W)mm x 0.36 (H)mm
(5) Number of Dots	320 (W) x 240 (H)Dots
(6) Duty	1/240
(7) LCD Display Mode	STN: Black and White(Normally White/Positive Image) Rear Polarizer: Transflective(High Transparency)
(8) Viewing Direction	6 O'clock
(9) Controller	SED1335(With 32KB SRAM)
(10) DC/DC Converter	Include
(11) Backlight	LED Backlight
(12) Weight	199 g(Approx.)

# AZ Displays, Inc.

## 2. ABSOLUTE MAXIMUM RATINGS

### (1) ELECTRICAL ABSOLUTE RATINGS

VSS=0V

ITEM	SYMBOL	MIN	MAX	UNIT	COMMENT
Power Supply for Logic	VDD-VSS	-0.3	7.0	V	
Input Voltage	VI	-0.3	VDD+0.3	V	
Static Electricity	-	-	-	-	Note 1

Note 1 LCM should be grounded during handling LCM.

### (2) ENVIRONMENTAL ABSOLUTE MAXIMUM RATINGS

ITEM	WIDE TEMP.			
	OPERATING		STORAGE	
	MIN.	MAX.	MIN.	MAX.
Ambient Temperature	-20	70	-40	80
Humidity (Without Condensation)	Note 2,4		Note 3,4	

Note 2  $T_a \leq 70^\circ\text{C}$  : 75%RH max

Note 3  $T_a$  at  $-40^\circ\text{C}$  will be  $< 120\text{hrs}$ , at  $80^\circ\text{C}$  will be  $< 120\text{hrs}$

Note 4 Background color will change slightly depending on ambient temperature.  
at phenomenon is reversible.

This phenomenon is reversible.

# AZ Displays, Inc.

## 3. ELECTRICAL CHARACTERISTICS

### 3-1. ELECTRICAL CHARACTERISTICS

(VDD = 4.5V±5%)

ITEM	SYMBOL	CONDITION		MIN.	TYP.	MAX.	UNIT
Power Supply for Logic	VDD-GND	-		4.23	4.5	4.73	V
Input Voltage	VIH	H level		0.7VDD	-	VDD	V
	VIL	L level		0	-	0.3VDD	V
Recommended LC Driving Voltage	VDD-VO	Duty=1/240	-20°C	25.4	25.7	26.0	V
			0°C	23.8	24.1	24.4	
			25°C	22.9	23.2	23.5	
			50°C	21.5	21.8	22.1	
			70°C	20.5	20.8	21.1	
Power Supply Current	IDD	OSCILLATOR=10MHz FLM = 99.27 Hz VDD=4.5 V VDD-VO=23.2 V PATTERN :CHECKER □ ■ □ ■ □ ■ ■ □ ■ □ ■ □		-	72	108	mA
Surface Luminance	L	(Dots All On)		-	23.5	35.0	cd/m <sup>2</sup>
		(Dots All Off)		60.0	70.3	-	

# AZ Displays, Inc.

## 4. OPTICAL CHARACTERISTICS

AT V<sub>OP</sub>

ITEM MODE		Cr(Contrast Ratio)										$\theta$ (Viewing Angle)		$\phi$ (Viewing Angle)	
		-20℃		0℃		25℃		50℃		70℃		25℃		25℃	
		MIN.	TYP.	MIN.	TYP.	MIN.	TYP.	MIN.	TYP.	MIN.	TYP.	MIN.	TYP.	MIN.	TYP.
S	J	4.5	5.5	5.5	6.5	5.5	6.5	4.5	5.5	3.0	4.0	-	66	-	±34
NOTE		NOTE 6										NOTE 5			

NOTE :

S : TRANSFLECTIVE  
G : NORMALLY WHITE

AT  $\phi=0^\circ$   $\theta=0^\circ$

ITEM	SYMBOL	CONDITION	MIN.	TYP.	MAX.	UNIT	NOTE
Response Time (rise)	Tr	-20℃	2000	4000	6000	ms	NOTE 2
		0℃	400	750	1100		
		25℃	125	250	375		
		50℃	60	120	180		
		70℃	35	70	105		
Response Time (fall)	Tf	-20℃	1000	2000	3000	ms	NOTE 2
		0℃	210	420	630		
		25℃	60	120	180		
		50℃	30	60	90		
		70℃	20	40	60		

# AZ Displays, Inc.

## 5. BLOCK DIAGRAM

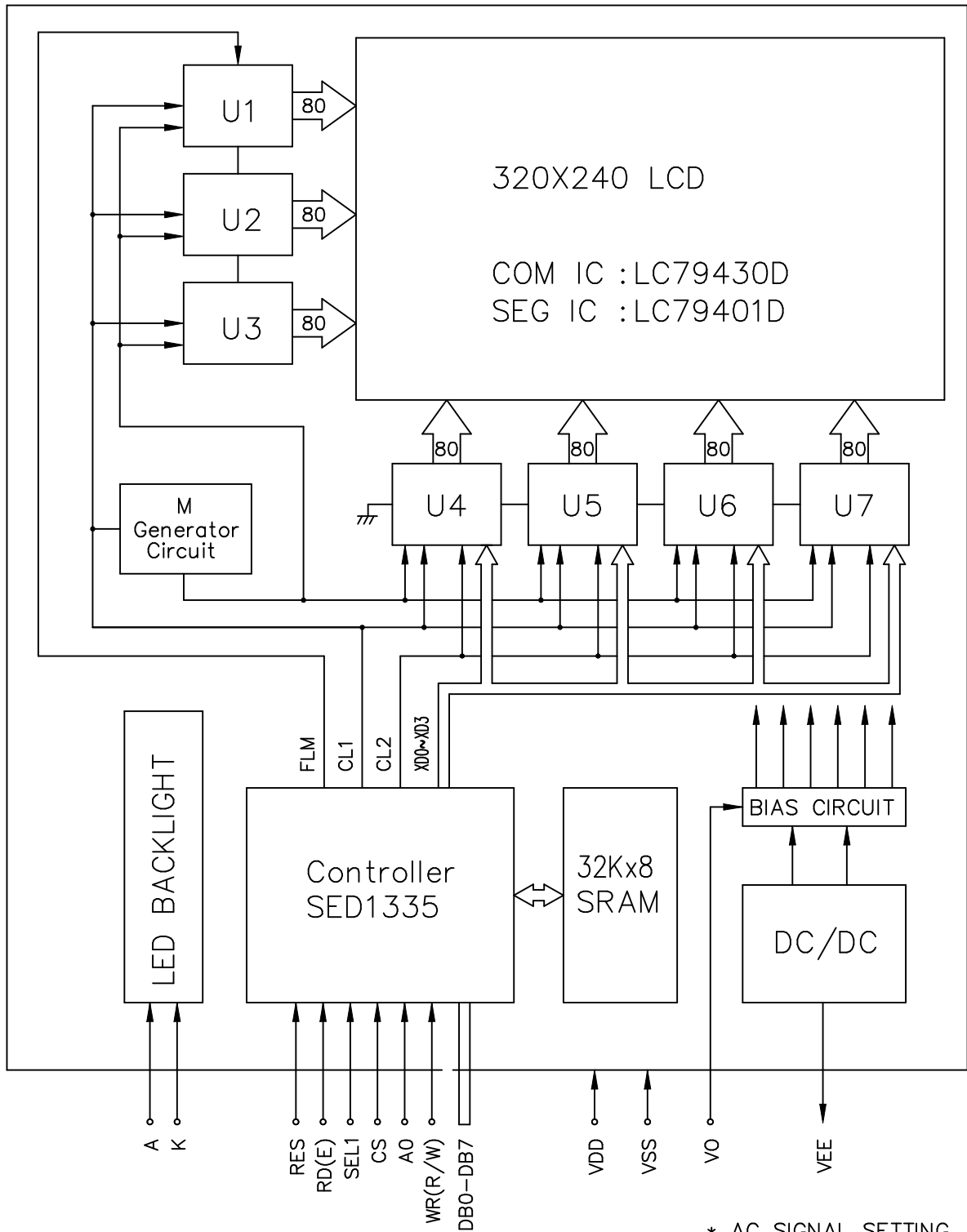

\* AC SIGNAL SETTING

J0	J1	J2	J3	J4	J5	J6	J7
L	H	H	L	L	L	L	L

# AZ Displays, Inc.

## 6. INTERNAL PIN CONNECTION

CN1: Pitch 1.25mm

Pin No.	Symbol	Function
1	VSS	Ground
2	VDD	Power supply for Logic
3	V0	Negative voltage power supply (Tuned from VDD-VEE)
4	A0	Data type select
5	WR (R/W)	8080 Family : Write signal 6800 Family : R/W signal
6	RD(E)	8080 Family : Read signal 6800 Family : Enable clock
7 5 14	DB0 S DB7	3-State I/O data bus
15	CS	Chip select
16	RES	This active Low input performs hardware reset on the SED 1335F
17	VEE	Supply voltage for LCD panel (-23V) (Generated from internal DC/DC converter)
18	SEL1	'0' FOR 8080 Family MPU , '1' for 6080 family MPU
19 5 22	N.C.	No connection

MATING CONNECTOR: ELCO 00-6207-34-19-14-000

CN2 : J.A.E./IL-G-4S-S3C2

Pin No.	Symbol	Level	Function
1	A	-	Power supply for LED
2	NC	-	-
3	NC	-	-
4	K	-	Ground

MATING CONNECTOR: J.A.E./IL-G-4P-S3T2-E  
or J.A.E./IL-G-4P-S3L2-E

# AZ Displays, Inc.

## 7. POWER SUPPLY

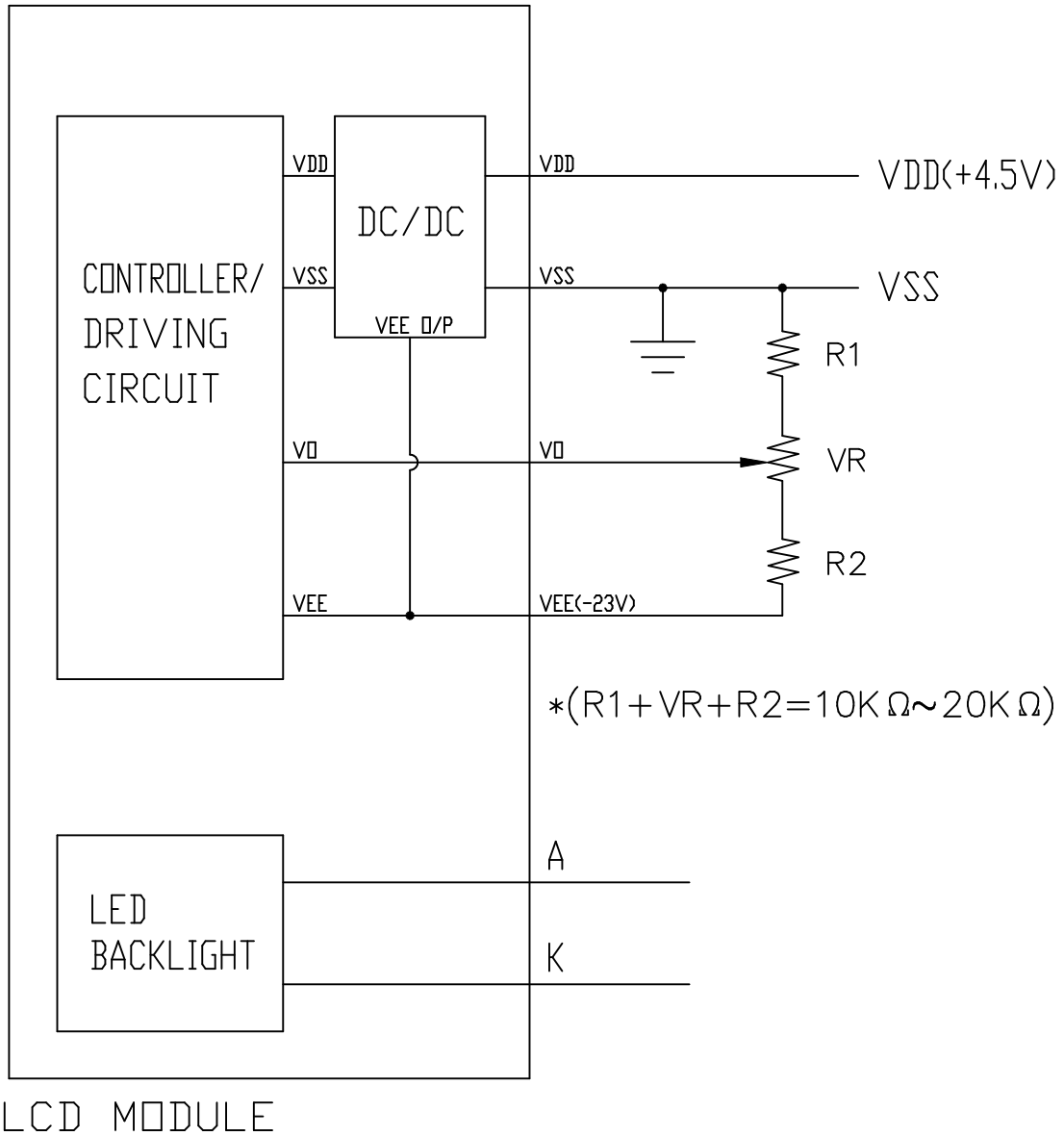

# AZ Displays, Inc.

## 8.1 TIMING CHARACTERISTICS

VDD=5.0V±5%

ITEM	ITEM	SYMBOL	MIN.	TYP.	MAX.	UNIT
A0, $\overline{\text{CS}}$	ADDRESS HOLD TIME	$t_{\text{AH8}}$	10	—	—	ns
	ADDRESS SETUP TIME	$t_{\text{AW8}}$	0	—	—	ns
$\overline{\text{WR}}, \overline{\text{RD}}$	SYSTEM CYCLE TIME	$t_{\text{CYC8}}$	1	—	—	ns
	STROBE PULSE WIDTH	$t_{\text{CC}}$	120	—	—	ns
D0 to D7	DATA HOLD TIME	$t_{\text{DH8}}$	5	—	—	ns
	DATA SETUP TIME	$t_{\text{DS8}}$	120	—	—	ns
	$\overline{\text{RD}}$ ACCESS TIME	$t_{\text{ACC8}}$	—	—	50	ns
	OUTPUT DISABLE TIME	$t_{\text{OH8}}$	10	—	50	ns

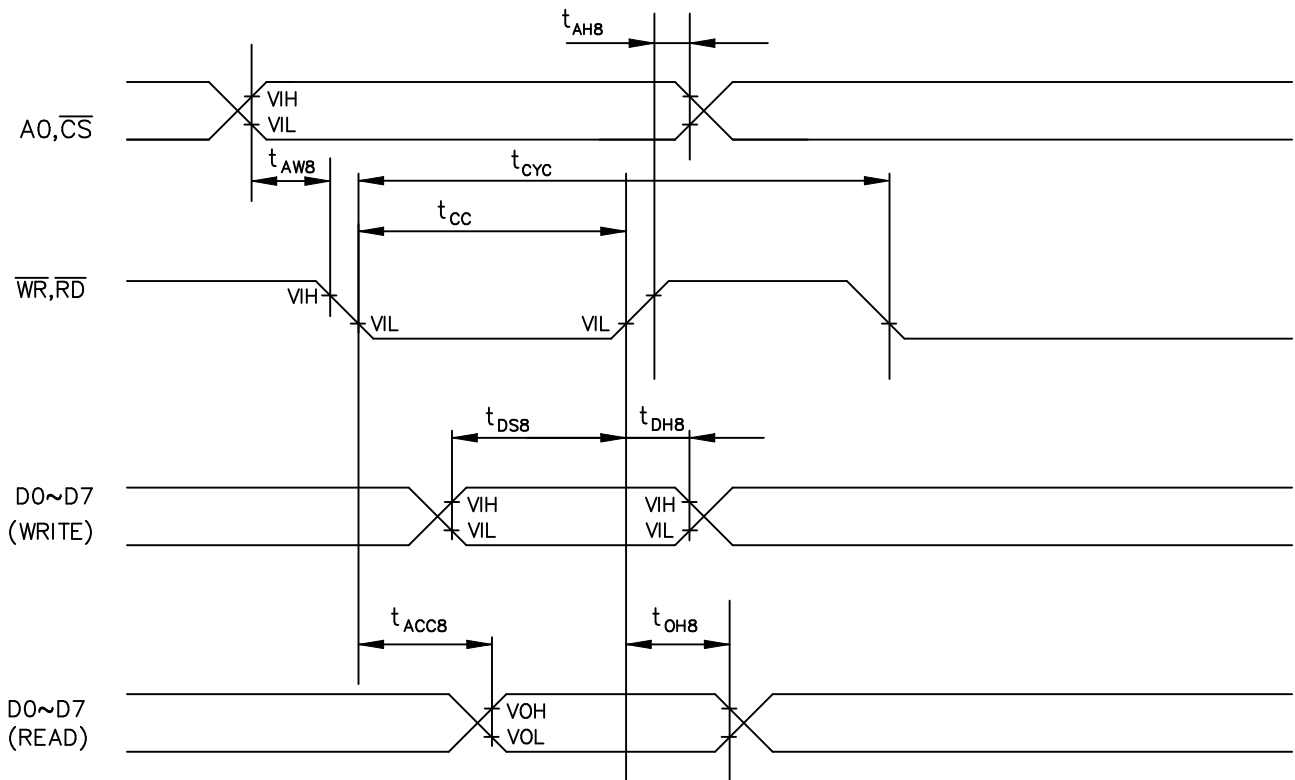



# AZ Displays, Inc.

## 8.2 TIMING CHART OF INPUT SIGNALS

VDD=5.0V±5%

ITEM	ITEM	SYMBOL	MIN.	TYP.	MAX.	UNIT
A0, $\overline{CS}$ , $\overline{WR}$	ADDRESS HOLD TIME	$t_{AH6}$	0	—	—	ns
	ADDRESS SETUP TIME	$t_{AW6}$	0	—	—	ns
	SYSTEM CYCLE TIME	$t_{CYC6}$	1	—	—	ns
D0 to D7	DATA HOLD TIME	$t_{DH6}$	0	—	—	ns
	DATA SETUP TIME	$t_{DS6}$	100	—	—	ns
	ACCESS TIME	$t_{ACC6}$	—	—	85	ns
	OUTPUT DISABLE TIME	$t_{OH6}$	10	—	50	ns
$\overline{RD}$	ENABLE PULSE WIDTH	$t_{RDW}$	120	—	50	ns

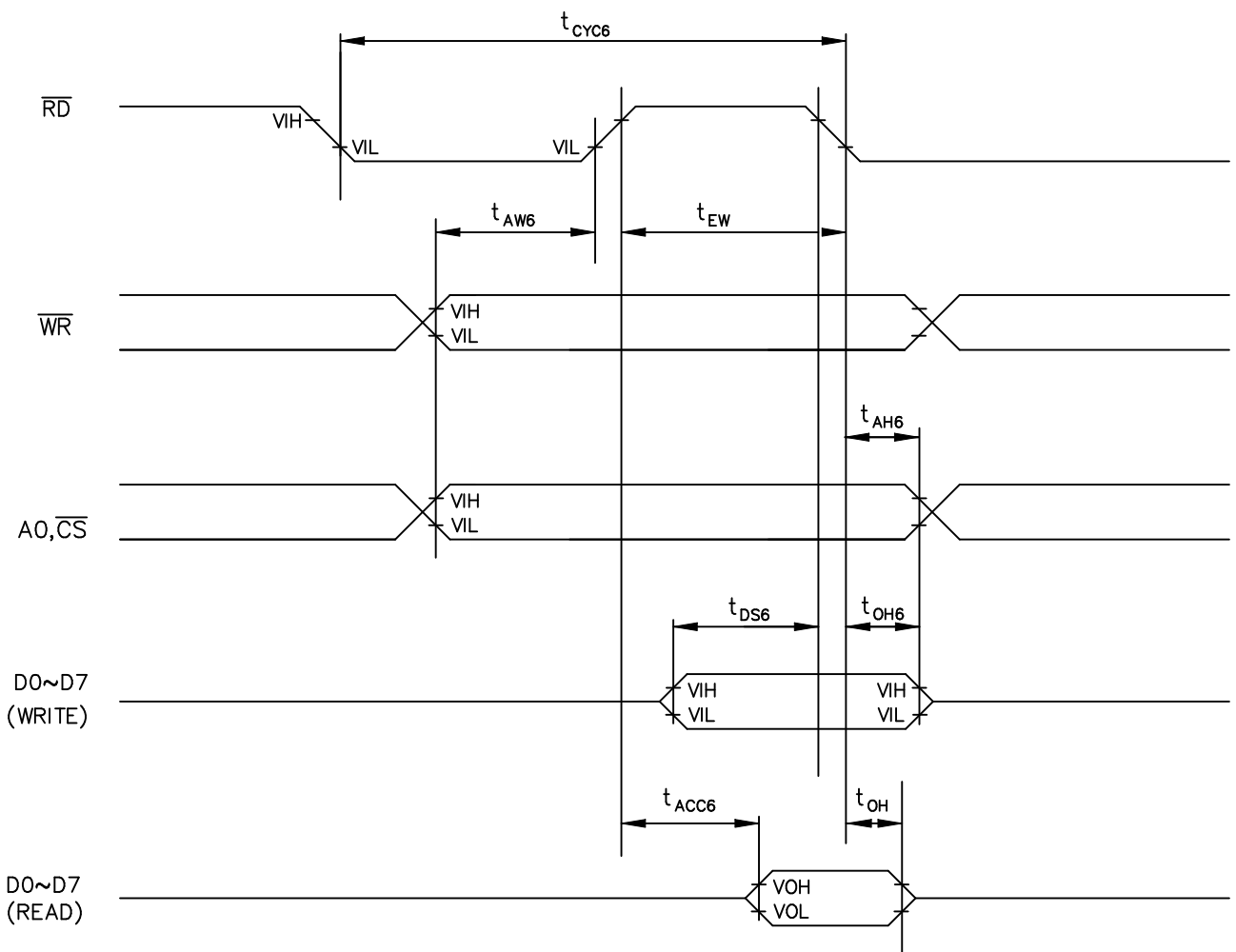

# AZ Displays, Inc.

## 8.4 POWER ON/OFF TIMING

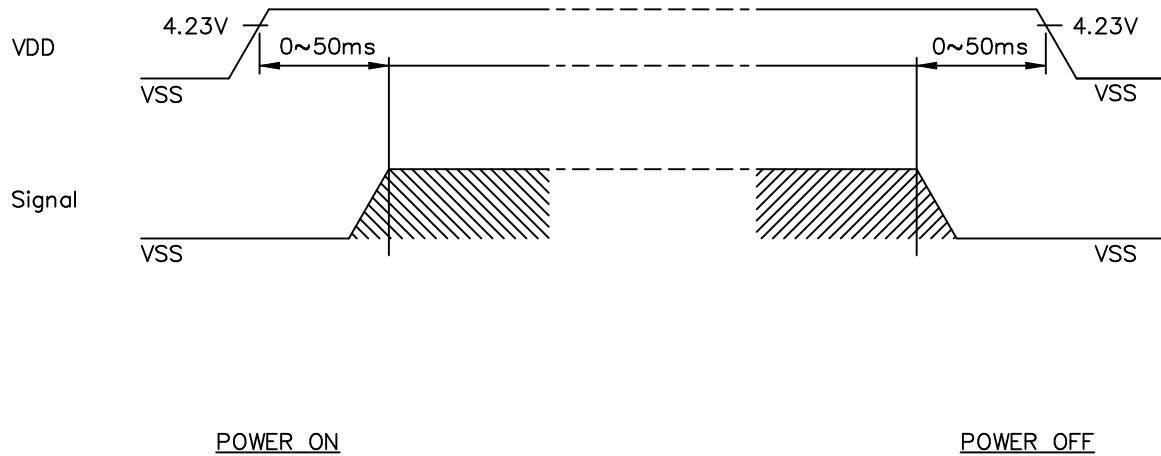

The missing pixels may occur when the LCM is driven beyond above power interface timing sequence.

# AZ Displays, Inc.

(NOTE 4)

Definition of Viewing Direction

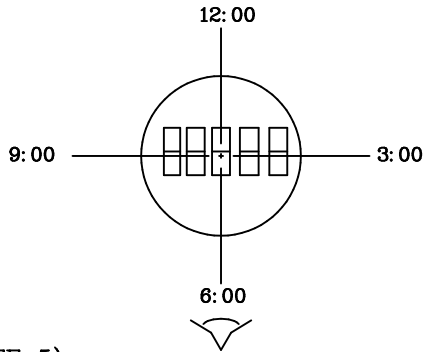

(NOTE 5)

Definition of Viewing Angle

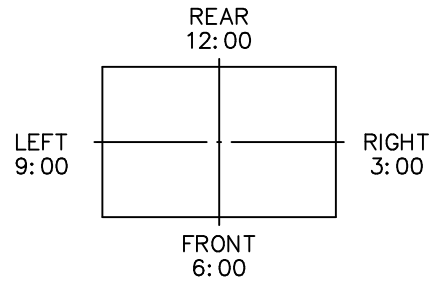
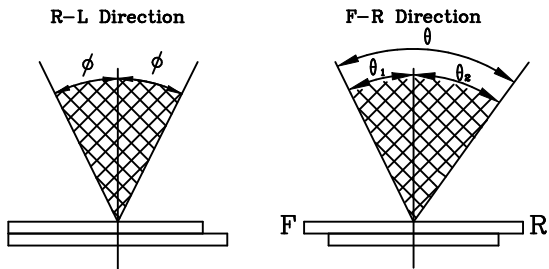

\*For This Product  
The Viewing Direction Is 6 O'clock  
So  $\theta_1 > \theta_2$

$$\theta = \theta_1 + \theta_2$$

\*Conditions

Operating Voltage :  $V_{op}$   
Frame Frequency : 70Hz  
Applying Waveform : 1/N duty 1/a bias  
Contrast Ratio : larger than 2

(NOTE 6)

Definition of Contrast Ratio (Cr)

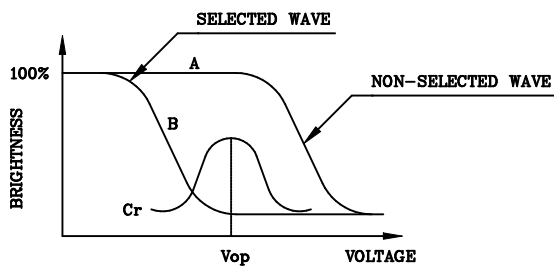

(positive type)

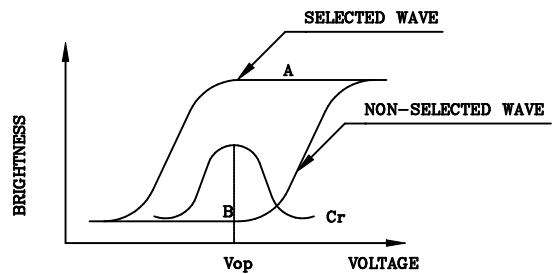

(negative type)

$$\text{Contrast Ratio} : Cr = A/B$$

\*Conditions

Viewing Angle : 0  
Frame Frequency : 70Hz  
Applying Waveform : 1/N duty 1/a bias

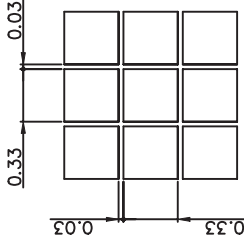

Detail "A"  
(Scale 30:1)

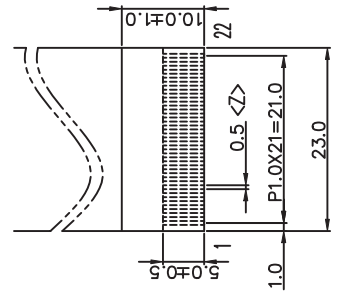

Detail "B"  
(Scale 1.5:1)

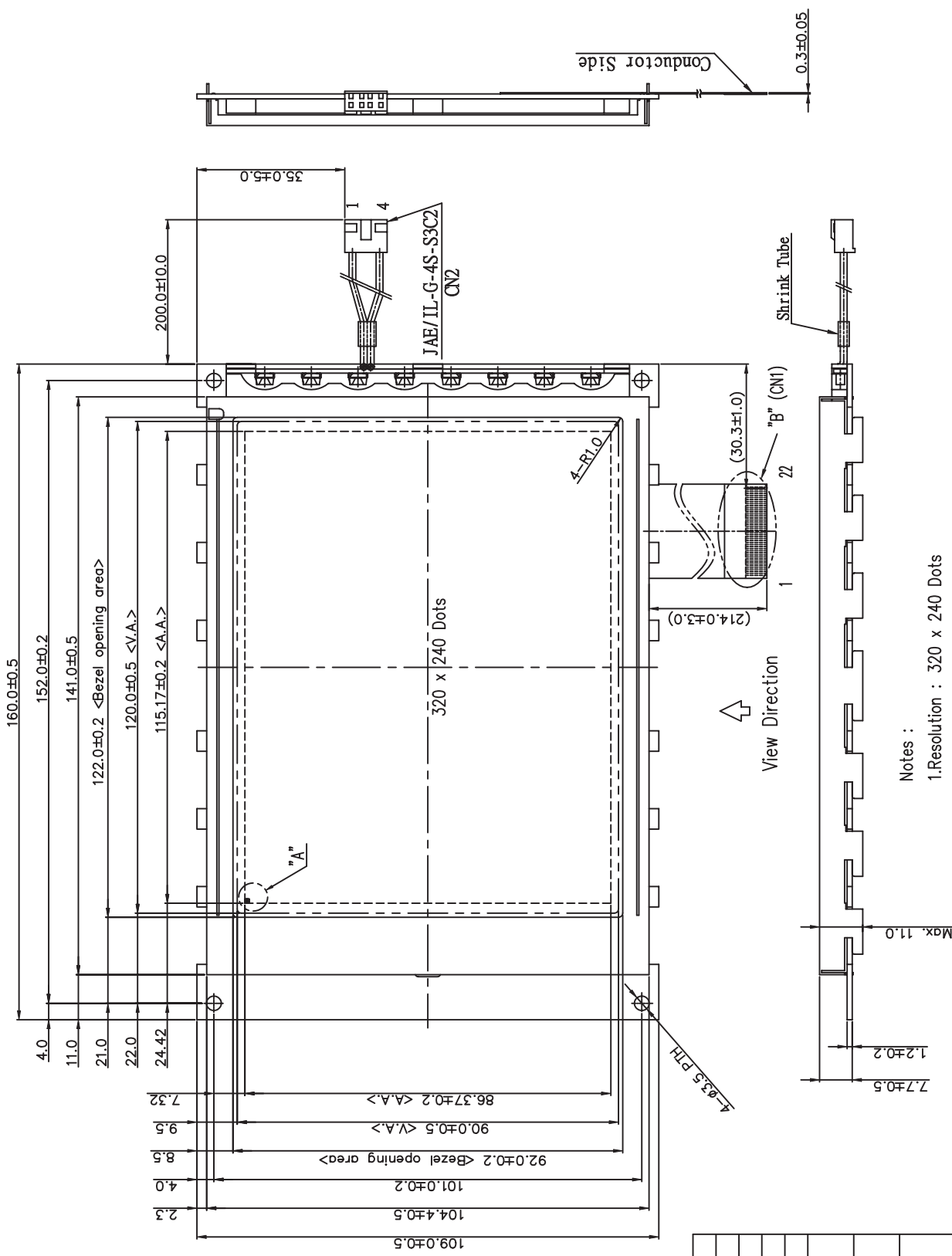

- Notes :
- 1. Resolution : 320 x 240 Dots
  - 2. Backlight : LED (White)
  - 3. Frame : 馬口鐵 (0.5mmt)

CNT: Pitch 1.25mm

Pin No./Symbol	Function
1 VSS	Ground
2 VDD	Power supply for Logic
3 V0	Negative voltage power supply
4 A0	Data type select
5 WR (R/W)	8080 Family : Write signal 6800 Family : R/W signal
6 RD(E)	8080 Family : Read signal 6800 Family : Enable clock
7 DB0	3-State I/O data bus
8 S	
14 DB7	
15 CS	Chip select
16 RES	This active Low input performs hardware reset on the SED 1335F
17 VEE	Supply voltage for LCD panel
18 SEL1	'0' FOR 8080 Family MPU , '1' for 6080 family MPU
19 S	No connection
20 N.C.	
22	

△ CNT : J.A.E./IL-G-4S-S3C2

Pin No./Symbol	Level	Function
1 A	-	Power supply for LED
2 NC	-	-
3 NC	-	-
4 K	-	Ground

NAME	DATE
APPROVE	
CHECK	
DESIGN	
DRAW	

TITLE	DWG-NO	UNIT	SCALE
AGM3224F w/ white LED	M032BD49A	mm	1/1

AZ DISPLAYS, INC.  
THIRD ANGLE PROJECT

