

OD-X8JXXXXX**Precision, Low Power Consumption, Fast Warm-up SC-cut OCXO in 20x20 mm Through Hole Package****Features**

- SC-cut crystal
- Extremely Low Power Consumption (125 mW)
- Fast Warm-up Time (30 s)
- High Stability (up to $\pm 1 \times 10^{-8}$)
- Low Aging (5×10^{-10} /day, 5×10^{-8} /year)
- Low Phase Noise (-160 dBc/Hz, TYP, floor)
- Sine Wave or HCMOS/TTL output
- 8 MHz to 160 MHz Frequencies Available

Applications

- Telecommunication Systems
- Data Communications
- GPS
- Battery Powered Systems and Equipment

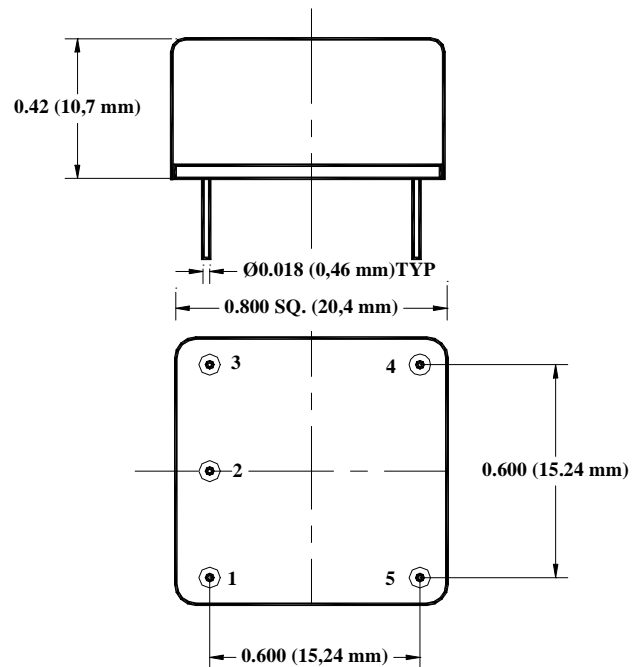
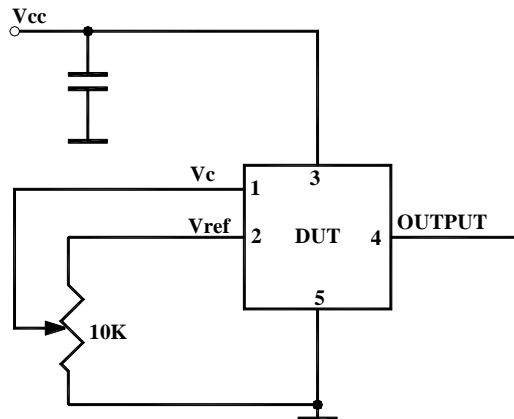

OD-X8JXXXXX Series

Parameter	Symb	Condition	Min	Typ	Max	Unit	Note
-----------	------	-----------	-----	-----	-----	------	------

Absolute Maximum Ratings

Input Break Down Voltage	Vcc		-0.5		5.5	V	
Storage temper.	Ts		-40		85	°C	
Control Voltage	Vc		-1		7	V	

Electrical

Frequency	F		8	10.000	160	MHz	1*	
Frequency stability	$\Delta F/F$	vs. Temp.		± 50		ppb	See chart below	
		vs. Supply		1	2	ppb/V		
Aging		per day per year		5E-10 1E-7			after 30 days 5E-8 available2*	
Allan Variance		.1s to 10s		1E-11				
SSB Phase Noise		1 Hz		-90		dBc/Hz	3*	
		10 Hz		-120				
		100 Hz		-150				
		1 KHz		-153				
		10 KHz		-160				
Retrace		After 30 minutes			± 10	ppb		
G-sensitivity		worst direction			± 1.0	ppb/G		
Input Voltage	Vcc		4.75 3.15	5.0 3.3	5.25 3.45	V	See chart below to specify	
Power consumption	P	steady state, 25°C steady state, -30°C start-up @ -30°C		0.125 0.35 0.5	0.15 0.7	W	Standard Operating Temperature, for Op Temp. 85 °C ad 20%	
Spectral Purity		Subharmonics Spurious Harmonics/Sine		-50 -35	-45 -30	dBc	At Higher Frequencies	
Load		10KOhm//15pF (HCMOS/TTL), 50 Ohm (Sinewave)						
Warm-up time	τ	to 0.1ppm accuracy		30	45	s		
Output Waveform		3.3V HCMOS/TTL compatible or Sinewave (+7± 3) dBm						
Control voltage	Vc		0		Vref	V		
Pull range		from nominal F	± 0.5	± 1		ppm		
Deviation slope		Monotonic, posit		0.4		ppm/V		
Stability	Vc0	@25°C, Fnom.	Vref/2-1	Vref/2	Vref/2+1	V		

All parameters for 10 MHz

Environmental and Mechanical

Operating temp. range	-30°C to 70°C Standard, Other options – see chart below
Mechanical Shock	Per MIL-STD-202, 30G, 11ms
Vibration	Per MIL-STD-202, 5G to 2000 Hz
Soldering Conditions	260°C for 10s Max leads only

Electrical Connections

Pin Out	Pin #1-Vc ; Pin#2 – Vref; Pin #3 – Vcc; Pin #4- Output ; Pin #5- GND;
---------	---

Notes:

1* Higher frequencies can be achieved either by using higher frequency crystals or by low noise analog harmonic multiplication. Both methods have advantages and drawbacks. If lowest possible phase noise on the noise floor is most important – high frequency crystal will be used. If phase noise close to the carrier and aging are more important – multiplication will be used. Please consult factory for your specific requirement.

2* Aging rate is usually proportional to the operating frequency, unless higher frequency is achieved by multiplication. Keep it in mind while specifying aging.

3* Phase noise deteriorates with frequencies going higher. If analog multiplication is used to achieve higher frequency the phase noise roughly follows the formula of additional 20LogN, where N is a multiplication factor across entire frequency offset range. If higher frequency is achieved by using higher frequency crystal phase noise close to the carrier deteriorates due to the lower Q of the crystal and is usually worse, compared to multiplied solution. On the noise floor, however it remains more or less the same. This design usually starts utilizing multiplication techniques in the range of 25 MHz to 35 MHz.

OD-X8JXXXXX Series

Creating a Part Number

OD - X 8J X XX X X

Package Code

OD 5 pin 20x20mm package

Supply Voltage

Code	Specification
0	5V ± 5%
A	3.3V ± 5%

Output

Code	Specification
T	TTL
S	Sinewave

Temperature Stability

Code	Specification
17	1x10 ⁻⁷
58	5x10 ⁻⁸
28	2x10 ⁻⁸
18	1x10 ⁻⁸
YZ	Yx10 ^{-Z}

Aging

Code	Specification
L	1x10 ⁻⁹ /Day
S	5x10 ⁻¹⁰ /Day

Temperature Range

Code	Specification
A	0°C to 50°C
B	-10°C to 60°C
C	0°C to 70°C
D	-20°C to 70°C
E	-30°C to 70°C
F	-40°C to 80°C

Not all combinations are available. Consult Factory.

