

Touch Screen Controller

Features

- 16 Pin SSOP or TSSOP
- Operates With Four Wire Touch Screen
- 8-Bit or 12-Bit A/D Converter
- Ratiometric Conversion Eliminates Screen Calibration
- 1 Auxiliary Analog Input
- Full Power Down Control
- Internal Bandgap Reference
- Serial Interface To Microprocessor

Description

The APT7846 is enhance function of APT7843 added battery and temperature monitor function and offer of a bandgap reference voltage for system user. The APT7846 Touch Screen Controller IC provides all the screen driver , A/D converter and control circuits to easily interface to 4 wire resistive touch screen. The IC continually monitors the screen waiting for a touch. When the screen touched , the IC performs A/D converter to determine the location of touch. Also , this device has 1 auxiliary input to A/D converter , allowing for the measurement of other input signal.

Applications

- PDAs
- Hand held computer
- Touch-screen mobile phone
- Portable electronic dictionary
- Smart IA

Pin Assignment

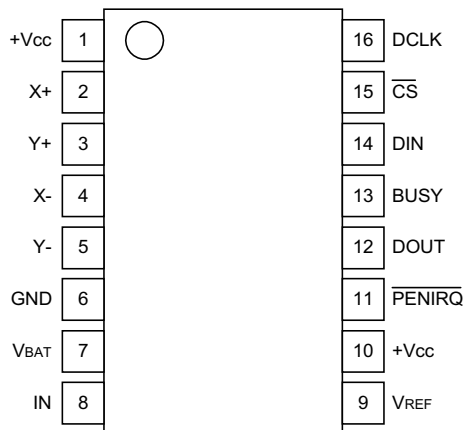

Ordering Information

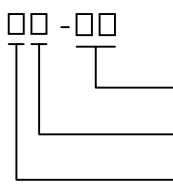
<p>APT7846 □□ - □□</p>  <p style="margin-left: 100px;"> Handling Code Temp. Range Package Code </p>	<p>Package Code N : SSOP O : TSSOP Temp. Range I : - 40 to 85°C Handling Code TU : Tube TR : Tape & Reel</p>
---	---

ANPEC reserves the right to make changes to improve reliability or manufacturability without notice, and advise customers to obtain the latest version of relevant information to verify before placing orders.

Block Diagram

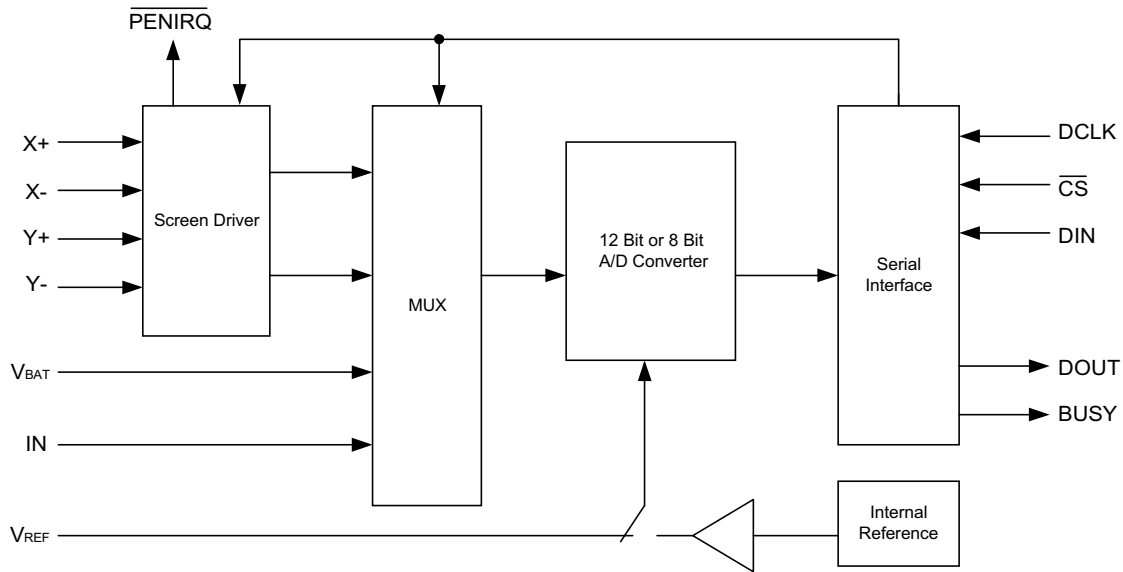

Pin Description

PIN	NAME	DESCRIPTION
1	+Vcc	Power Supply , 2.7V to 5V.
2	X+	Connect to X+ on touch screen.
3	Y+	Connect to Y+ on touch screen.
4	X-	Connect to X- on touch screen.
5	Y-	Connect to Y- on touch screen.
6	GND	Ground
7	V _{BAT}	Measure Battery Input.
8	IN	Auxiliary input of A/D converter.
9	V _{REF}	Voltage Reference Input or Output.
10	+Vcc	Power Supply , 2.7V to 5V.
11	\overline{PENIRQ}	Pen interrupt. (requires to 100k Ω pull-up resistor externally)
12	DOUT	Serial Data Output. This output is high impedance when \overline{CS} is HIGH.
13	BUSY	Busy Output. This output is high impedance when \overline{CS} is HIGH.
14	DIN	Serial Data input.
15	\overline{CS}	Chip Select. (Active Low)
16	DCLK	Serial Clock.

Electrical Characteristics

At $T_A = -40^{\circ}\text{C}$ to 85°C , $V_{CC} = +2.7\text{V}$, $V_{REF} = +2.5\text{V}$, $f_{SAMPLE} = 125\text{kHz}$, $f_{CLK} = 16 \cdot f_{SAMPLE} = 2\text{MHz}$, 12-bit mode, and digital inputs = GND or V_{CC} , unless otherwise noted.

PARAMETER	CONDITIONS	APT7846			UNIT
		MIN	TYP	MAX	
DC ACCURACY					
Resolution			12		Bits
No missing code		11			Bits
Integral Nonlinearity				± 2	LSB
Offset Error				± 6	LSB
Offset Error Match			0.1	1	LSB
Gain Error				± 4	LSB
Gain Error Match			0.1	1	LSB
Noise			30		$\mu\text{V rms}$
Power Supply Rejection			70		dB
REFERENCE INPUT					
V_{REF} Input Voltage Range		1.0		V_{CC}	
DC Leakage Current			± 1		μA
V_{REF} Input Impedance	$\overline{CS} = \text{GND or } V_{CC}$		5		$\text{G}\Omega$
V_{REF} Input Current			13	40	μA
	$F_{SAMPLE} = 12.5 \text{ kHz}$		2.5		μA
	$CS = V_{CC}$			3	μA
REFERENCE OUTPUT					
Internal Reference Voltage		2.4	2.5	2.6	V
Input Impedance	Internal Reference Off		1		$\text{G}\Omega$
DYNAMIC PERFORMANCE					
Aperture Delay			30		ns
Aperture Jitter			100		ps
Channel to Channel Isolation	$V_{IN} = 2.5\text{Vp-p}$; $F_{IN} = 50\text{kHz}$		100		dB
CONVERSION RATE					
Conversion Time				12	DCLK cycles
Track/Hold Acquisition Time		3			DCLK cycles
Throughput Rate				125	KSPS
SWITCH DRIVERS					
On-Resistance					
Y+, X+			4	15	Ω
Y-, X-			4	15	Ω

Electrical Characteristics (Cont.)

PARAMETER	CONDITIONS	APT7846			UNIT
		MIN	TYP	MAX	
LOGIC INPUTS					
Input High Voltage , V_{INH}	$ I_{INH} \leq +5\mu A$	2.4			V
Input Low Voltage , V_{INL}	$ I_{INL} \leq +5\mu A$			0.8	V
Input Current , I_{IN}				± 1	μA
Input Capacitance , C_{IN}				10	pF
LOGIC OUTPUTS					
Output High Voltage , V_{OH}	$ I_{OH} \leq -250\mu A$	$V_{CC}-0.2$			V
Output Low Voltage , V_{OL}	$ I_{OL} \leq 250\mu A$			0.4	V
PENIRQ output low voltage , V_{OL}				0.2	V
Floating-State Leakage Current				± 10	μA
Floating-State Output Capacitance				10	pF
Output Coding		Straight (Natural) Binary			
ANALOG INPUT					
Input Voltage Ranges		0		V_{REF}	V
DC Leakage Current			± 0.1		μA
Input Capacitance			30		pF
POWER REQUIREMENTS					
V_{CC}		2.7		3.6	V
I_{CC}	Digital I/Ps =0V or V_{CC}				
Normal Mode (Static)	$V_{CC} = 3.6V$			650	μA
Normal Mode ($F_{SAMPLE} = 12.5kSPS$)	$V_{CC} = 3.6V$			540	μA
Shutdown Mode(Static)				3	μA
Showdown	$V_{CC} = 3.6V$			3.6	μW
BATTERY MEASURE					
Input Voltage Range		0.5		6	V
Input impedance					
Sample Battery On			10		K Ω
Sample Battery Off			1		G Ω
Accuracy	V_{REF}	-2		2	%
TEMPERATURE RANGE					
Normal Operation		-40		85	$^{\circ}C$

Note : (1) LSB means least Significant Bit. With V_{REF} equal to +2.5V , one LSB is 610 μV

Chip Overview

The APT7846 is a successive approximation analog-to-digital (A/D) converter based around a capacitive redistribution DAC. Figure 1 show basic operation of the APT7846.

The APT7846 communicates via a 4-wire serial interface. The device requires an external reference voltage V_{ref} . The value of the reference voltage directly sets the input range of the converter. Otherwise you can use internal reference Voltage to do conversion.

The APT7846 primary function is to control resistive touchscreens. When a touch is detected , pen interrupt pin will go low to wake up external microprocessor . The microprocessor writes register to initiate

conversion.

This A/D converter may also be used to measure voltage presented on the IN Pin or to measure battery presented on the V_{BAT} Pin.

Analog Input

The analog input to the converter is provided via a four-channel multiplexer. Figure 2 shows a simplified diagram of the APT7846 with the difference input of the A/D converter , and the converter's reference. Table I and Table II also show the relationship between the A2 , A1 , A0 , SER/DFR and the configuration of the APT7846. See the section of single-ended reference mode and differential reference mode for more details.

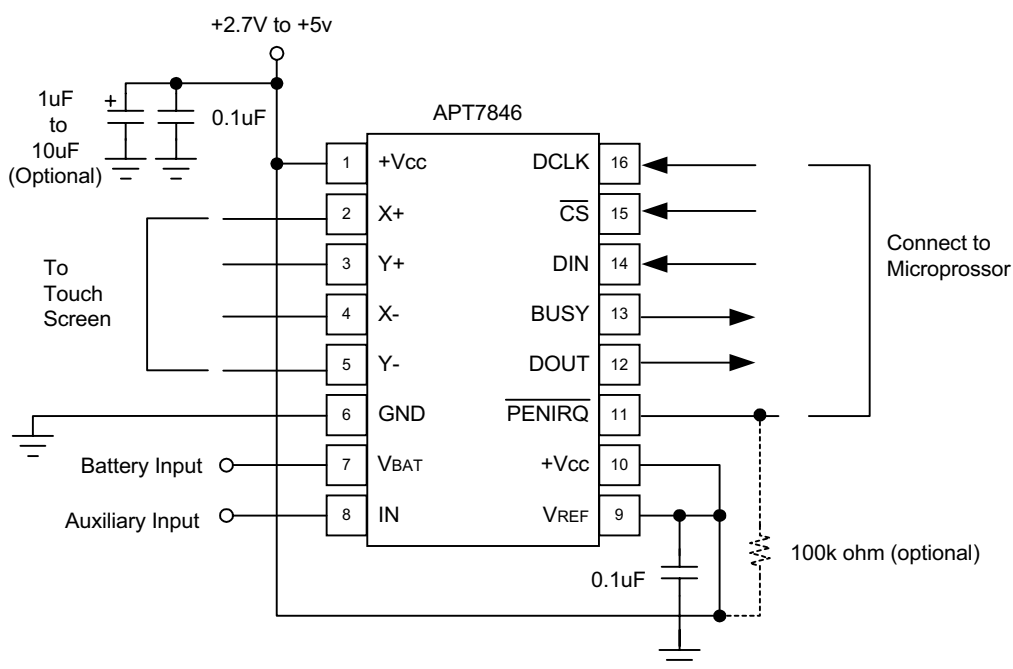

FIGURE 1. Basic Operation of the APT7846

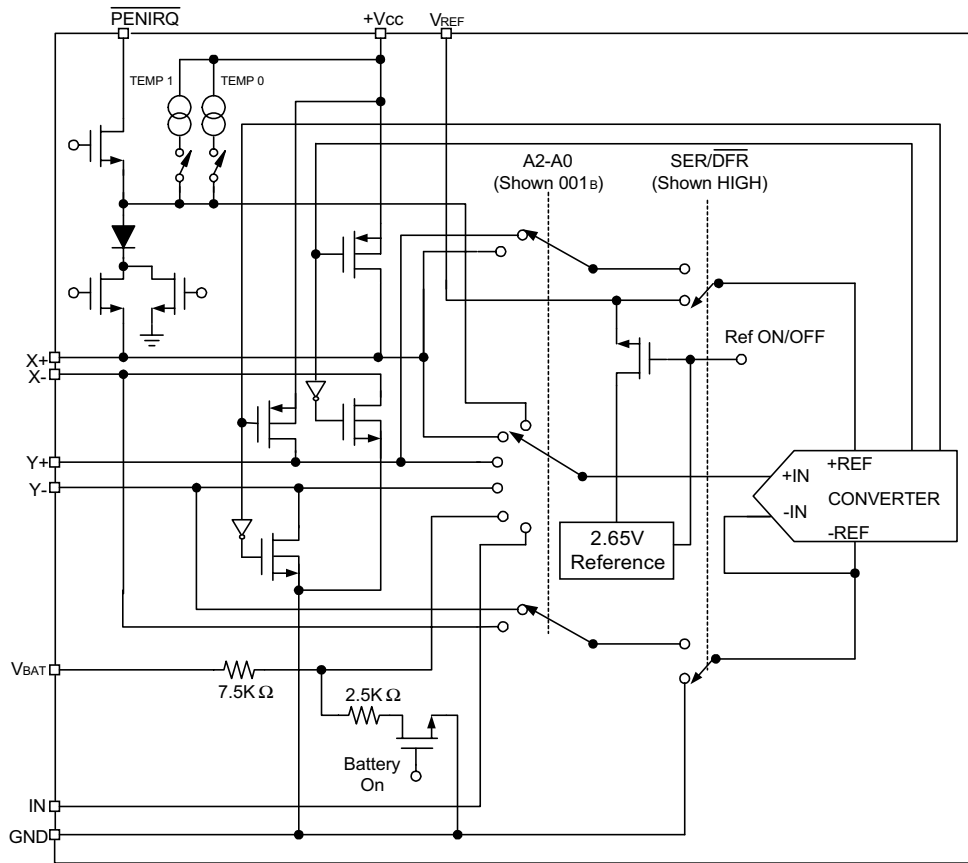

FIGURE 2. Simplified Diagram of Analog Input

A2	A1	A0	V _{BAT}	AUX _{IN}	TEMP	Y-	X+	Y+	Y-POSITION	X-POSITION	Z ₁ -POSITION	Z ₂ -POSITION	X-DRIVERS	Y-DRIVERS
0	0	0			+IN(TEMP 0)								OFF	OFF
0	0	1					+IN		Measure				OFF	ON
0	1	0	+IN										OFF	OFF
0	1	1					+IN			Measure			X-,ON	Y+,ON
1	0	0									Measure		X-,ON	Y+,ON
1	0	1						+IN		Measure			ON	OFF
1	1	0		+IN									OFF	OFF
1	1	1			+IN(TEMP 1)								OFF	OFF

TABLE I. Input Configuration , Single-Ended Reference Mode (SER/DFR HIGH).

A2	A1	A0	+REF	-REF	Y-	X+	Y+	Y-POSITION	X-POSITION	Z ₁ -POSITION	Z ₂ -POSITION	DRIVERS ON
0	0	1	Y+	Y-		+IN		Measure				Y+,Y-
0	1	1	Y+	X-		+IN				Measure		Y+,X-
1	0	0	Y+	X-	+IN						Measure	Y+,X-
1	0	1	X+	X-			+IN		Measure			X+,X-

TABLE II. Input Configuration , Differential Reference Mode (SER/DFR LOW).

Single-Ended reference mode

Figure 3 shows the diagram of single-ended reference mode.

This application shows the measurement of current Y position is made by connecting the X+ input to the A/D converter, turning on the Y+ and Y- drivers, and digitizing the voltage on X+. For this measurement, the resistance in the X+ lead does not affect the conversion. However, since the resistance between Y+ and Y- is fairly low, the on-resistance of the Y drivers does make a small difference. Under the situation outlined so far, it would not be possible to achieve a zero volt input or a full-scale input regardless of where the pointing device is on the touch screen because some voltage is lost across the internal switches. This situation can be remedied if use differential reference mode

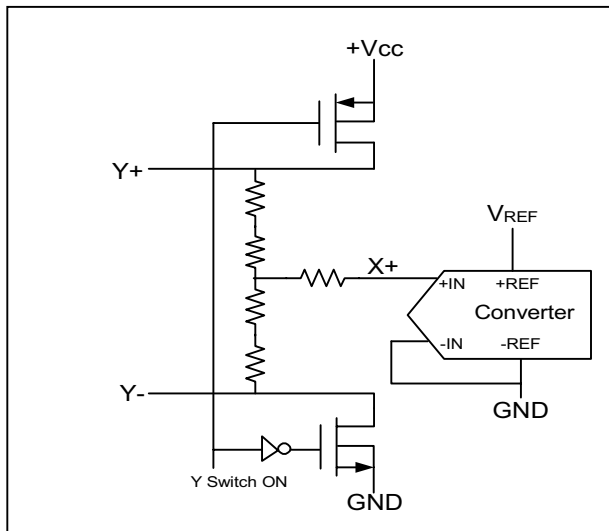

FIGURE 3. Single-Ended Reference Mode (SER/DFRHigh, A2=Low, A1=Low, A0=High)

Differential reference mode

As shown in Figure 4, by setting the SER/DFR bit LOW, the +REF and -REF inputs are connected directly to Y+ and Y-. This makes the analog-to-digital conversion ratiometric.

The result of the conversion is always a percentage of the external resistance, regardless of how it changes in relation to the on-resistance of the internal switches. Note that there is an important consideration regarding power dissipation when using the ratiometric mode of operation, the external device should be powered throughout the acquisition and conversion periods.

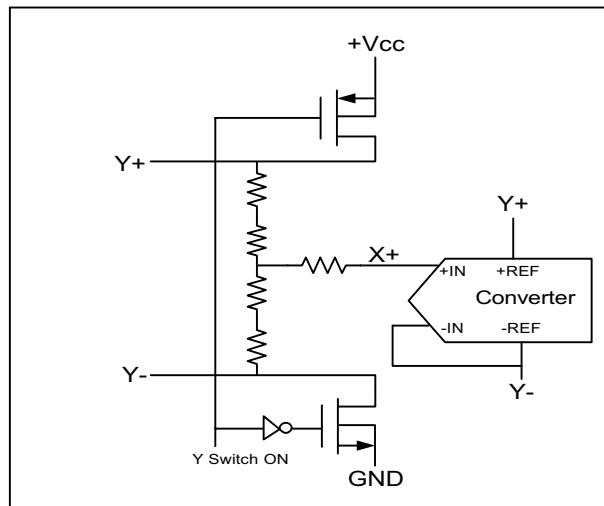

Figure 4. Differential Reference Mode (SER/DFR LOW, A2=Low, A1=Low, A0=High)

Serial Interface

Data is written to, and read from, the APT7846 via the serial port. The serial port has 4 pins - serial clock (DCLK), chip select (\overline{CS}), data in (DIN) and data out (DOUT). The DCLK acts on the rising edge. The \overline{CS} acts as a reset for the serial port with \overline{CS} goes low initiating a conversion cycle. The cycle consists of 2 parts - a write followed by a read. Figure 5 shows the typical timing of the APT7846's serial interface. A total of 24 clock cycles will complete one conversion.

Also shown in Figure 5 is the placement and order of the control bits within the control byte. Tables III and IV give detailed information about these bits.

The first bit, the 'S' bit, must always be HIGH and indicates the start of the control byte. The APT7846 will ignore inputs on the DIN pin until the start bit S detected.

The next three bits (A2 - A0) select the active input channel or channels of the input multiplexer (see Tables I and II and Figure 2).

The MODE bit determines the number of bits for each conversion, either 12 bits (LOW) or 8 bits (HIGH).

The SER/DFR bit controls the reference mode: either single-ended (HIGH) or differential (LOW). (The differential mode is also referred to as the ratiometric conversion mode.)

The last two bits (PD1 - PD0) select the power-down mode as shown in Table V. If both inputs are HIGH, the device is always powered up. If both inputs are LOW, the device enters a power-down mode between conversions.

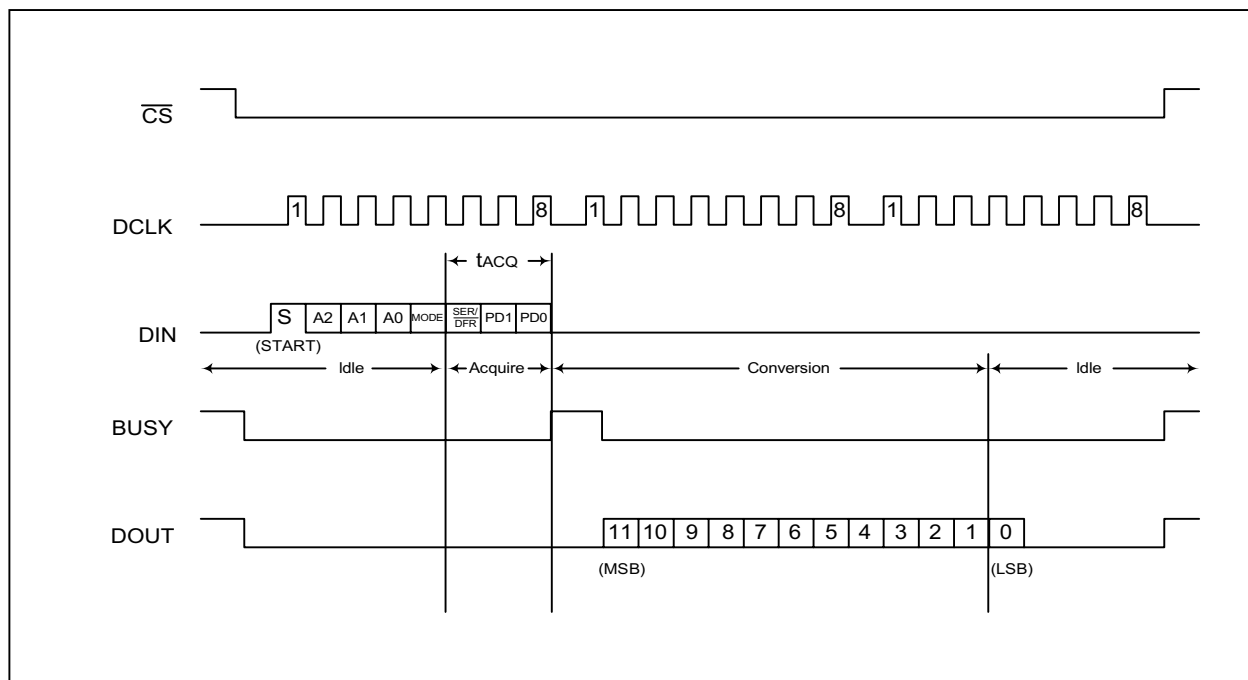

FIGURE 5. Conversion Timing , 24-Clocks per Conversion , 8-bit Bus Interface. No DCLK Delay Required with Dedicated Serial Port.

Bit 7 (MSB)	Bit 6	Bit 5	Bit 4	Bit 3	Bit 2	Bit 1	Bit 0 (LSB)
S	A2	A1	A0	MODE	SER/DFR	PD1	PD0

TABLE III. Order of the Control Bits in the Control Byte.

BIT	NAME	DESCRIPTION
7	S	Start Bit. Control byte starts with first HIGH bit on DIN. A new control byte can start every 15th clock cycle in 12-bit conversion mode or every 11th clock cycle in 8-bit conversion mode.
6-4	A2-A0	Channel Select Bits. Along with the SER/DFR bit, these bits control the setting of the multiplexer input, switches, and reference inputs, as detailed in Tables I and II.
3	MODE	12-Bit/8-Bit Conversion Select Bit. This bit controls the number of bits for the following conversion: 12-bits(LOW) or 8-bits(HIGH).
2	SER/DFR	Single-Ended/Differential Reference Select Bit. Along with bits A2-A0, this bit controls the setting of the multiplexer input, switches, and reference inputs, as detailed in Tables I and II.
1-0	PD1-PD0	Power-Down Mode Select Bits. See Table V for details.

TABLE IV. Descriptions of the Control Bits within the Control Byte.

PD1	PD0	PENIRQ	DESCRIPTION
0	0	Enabled	Power-down between conversions. When each conversion is finished, the converter enters a low power mode.
0	1	Enabled	Reference is OFF.
1	0	Enabled	Reference is ON
1	1	Disabled	No power-down between conversions, device is always powered.

TABLE V. Power-Down Selection.

TEMPERATURE MEASUREMENT

The temperature measurement technique used in the APT7846 relies on the characteristics of a semiconductor junction operation at a fixed current level. The forward bipolar transistor voltage (V_{BE}) has a well defined characteristic versus temperature.

If you got 25°C value of the V_{BE} voltage then measured ambient temperature to monitor the voltage variance.

There are two mode to measure temperature. The Temp 0 requires calibration at a known temperature, but only requires a single reading to predict the ambient temperature. The PENIRQ bipolar transistor is used during this measurement, the A/D with an address of A2=0, A1=0 and A0=0 (see Table I and Figure 6). This voltage is typically 600mV at +25°C, with a 20µA current through it. The TC of temperature Temp 0 is very consistent at -2.1 mV/°C. Catch the bipolar transistor voltage on room temperature, in memory, for calibration purposes by the user.

The Temp 1 requires two steps to measure temperature.

First step read Temp 0 voltage. Second step read address of A2=1, A1=1, and A0=1, with an 82 times large current.

The voltage difference between the Temp 0 and Temp 1 conversion using 82 times the bias.

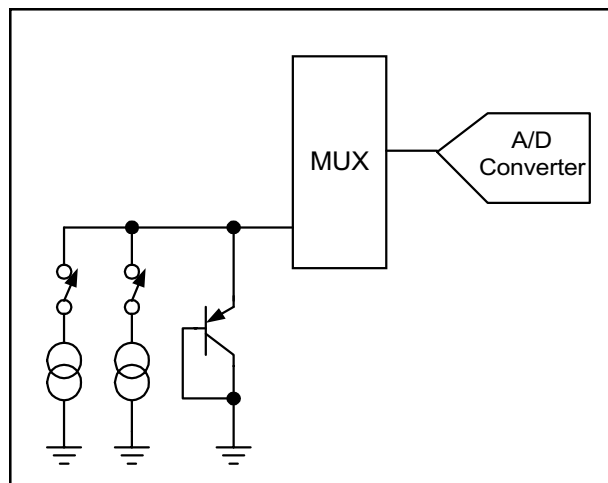

FIGURE 6. Functional Block Diagram of Temperature Measurement Mode.

Current will be represented by $kT/q * \ln(N)$, where N is the current ratio = 82, k = Boltzmann's constant ($1.38054 * 10e-23$ electrons volts/degrees Kelvin), q = the electron charge ($1.602189 * 10e-19$ C), and T = the temperature in degrees Kelvin. The resultant equation for solving for °K is :

$$^{\circ}\text{K} = q * \Delta V / (k * \ln(N)) \quad (1)$$

where, $\Delta V = V(I_{82}) - V(I_1)$ (mV)

$$\therefore ^{\circ}\text{K} = 2.30 \Delta V (^{\circ}\text{K} / \text{mV})$$

$$^{\circ}\text{C} = 2.30 \Delta V (\text{mV}) - 273 ^{\circ}\text{K}$$

BATTERY MEASUREMENT

An added feature of the APT7846 is the ability to monitor the battery voltage, as shown in Figure7. The battery voltage can vary from 0.5V to 6V, while maintaining the voltage to the APT7846 at 2.7V, 3.3V, etc. The input voltage (V_{BAT}) is divided down by 4 so that a 6.0V battery voltage is represented as 1.5V to the ADC. This simplifies the multiplexer and control logic. In order to minimize the power consumption, the divider is only ON during the sampling of DIN to A2=0, A1=1, and A0=0. Tables I and II show the relationship between the control bits and configuration of the APT7846.

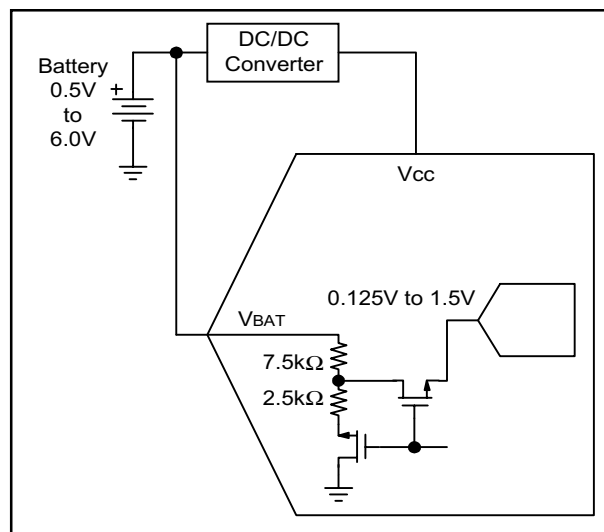

FIGURE 7. Battery Measurement Functional Block Diagram.

Calculating Touch Resistance

There are total of four measurements possible :

MEASURE	DRIVE	PIN MEASURED	RESULT
X-position	X+,X-	Y+	A
Y-position	Y+,Y-	X+	B
Z ₁ -position	Y+,X-	X+	C
Z ₂ -position	Y+,X-	Y-	D

FIGURE 8 is Pressure measurement diagram. where the result is a number from 0 to 4096.

From simple network theory , R_{THOUGH} can be represented in many ways , 2 are given below :

$$R_{THOUGH} = R_x * \frac{A}{4096} * \left(\frac{D}{C} - 1 \right) \quad \text{where } R_x = X \text{ plate resistance}$$

or
$$R_{THOUGH} = \frac{R_x}{C} * \frac{A}{4096} * (4096 - C) - R_y + R_y * \frac{B}{4096} \quad \text{where } R_y = Y \text{ plate resistance}$$

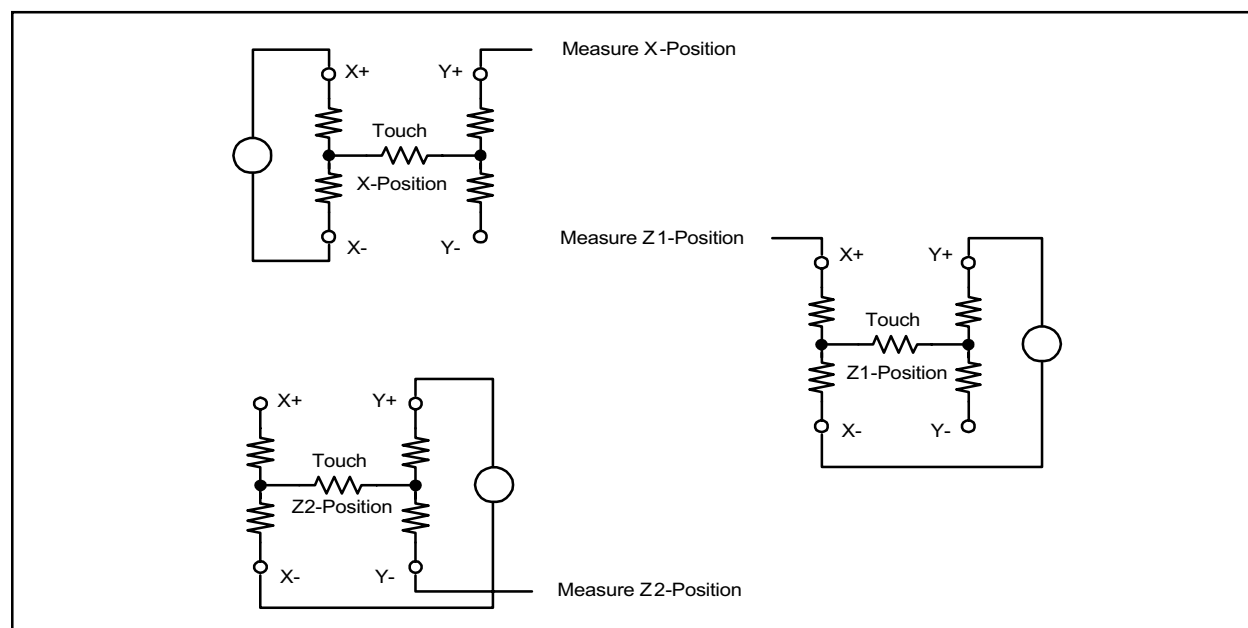

FIGURE 8 is Pressure measurement diagram.

Internal Reference

The APT7846 has an internal 2.5V voltage reference that can be turned ON and OFF with the power-down address PD1=1(see table V). Typically , the internal reference voltage is only used in the single-ended mode for battery monitoring , temperature measurement , and for utilizing the auxiliary input. Optimal

touch-screen performance is achieved when utilizing the differential mode. The internal reference voltage of the APT7846 must be commanded to be off to maintain compatibility with the APT7843. Therefore , after power-up , a write of PD1=0 is required to insure the reference is off.

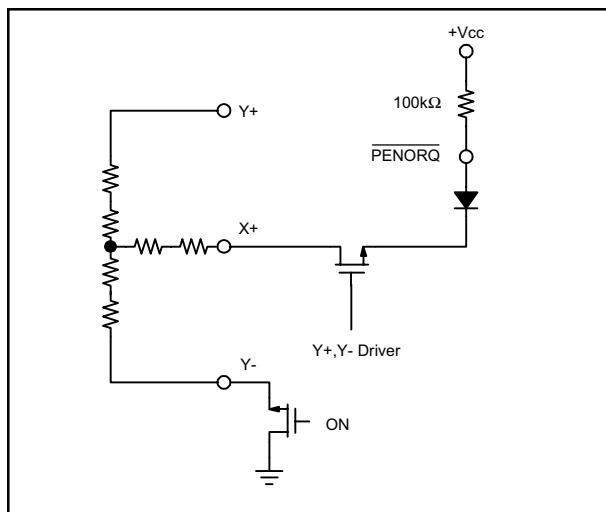

FIGURE 9. $\overline{\text{PENIRQ}}$ Functional Block Diagram

PENIRQ Output

The pen interrupt output function is detailed in Figure 9. By connecting a pull-up resistor to Vcc (typically 100kΩ), the PENIRQ output is HIGH. While in the power-down mode, with PD0 = PD1 = 0, the Y-driver is ON and connected to GND and the PENIRQ output is connected to the X+ input. When the panel is touched, the X+ input is pulled to ground through the touch screen and PENIRQ output goes LOW due to the current path through the panel to GND, initiating an interrupt to the processor. During the measurement cycles for X- and Y-Position, the PENIRQ output diode will be internally connected to GND and the X+ input disconnected from the PENIRQ diode to eliminate any leakage current from the pull-up resistor to flow through the touch screen, thus causing no errors.

16-Clocks or 15-Clocks per Conversion

The APT7846 will allow a conversion every 16 clock cycles, as shown in Figure 10. This figure shows possible serial communication occurring with other serial peripherals between each byte transfer between the processor and the converter.

Figure 11 provides the fastest way to clock the APT7846. This method will not work with the serial interface of most microcontrollers and digital signal processors as they are generally not capable of providing 15 clock cycles per serial transfer. However,

this method could be used with field programmable gate arrays (FPGAs) or application specific integrated circuits (ASICs). (Note that this effectively increases the maximum conversion rate of the converter).

AC Timing

Figure 12 and Table VI provide detailed timing of the APT7846.

SYMBOL	DESCRIPTION	MIN	TYP	MAX	UNIT
t_{ACQ}	Acquisition Time	1.5			μs
t_{DS}	DIN Valid Prior to DCLK Rising	100			ns
t_{DH}	DIN Hold After DCLK HIGH	10			ns
t_{DO}	DCLK Falling to DOUT Valid			200	ns
t_{DV}	$\overline{\text{CS}}$ Falling to DOUT Enabled			200	ns
t_{TR}	$\overline{\text{CS}}$ Rising to DOUT Disabled			200	ns
t_{CSS}	$\overline{\text{CS}}$ Falling to DCLK Rising	100			ns
t_{CSH}	$\overline{\text{CS}}$ Rising to DCLK Ignored	0			ns
t_{CH}	DCLK HIGH	200			ns
t_{CL}	DCLK LOW	200			ns
t_{BD}	DCLK Falling to BUSY Rising			200	ns
t_{BDV}	$\overline{\text{CS}}$ Falling to BUSY Enabled			200	ns
t_{BTR}	$\overline{\text{CS}}$ Rising to BUSY Disable			200	ns

TABLE VI. Timing Specifications (+Vcc=+2.7V and Above, $T_A=-40^\circ\text{C}$ to $+85^\circ\text{C}$, $C_{LOAD}=50\text{pF}$).

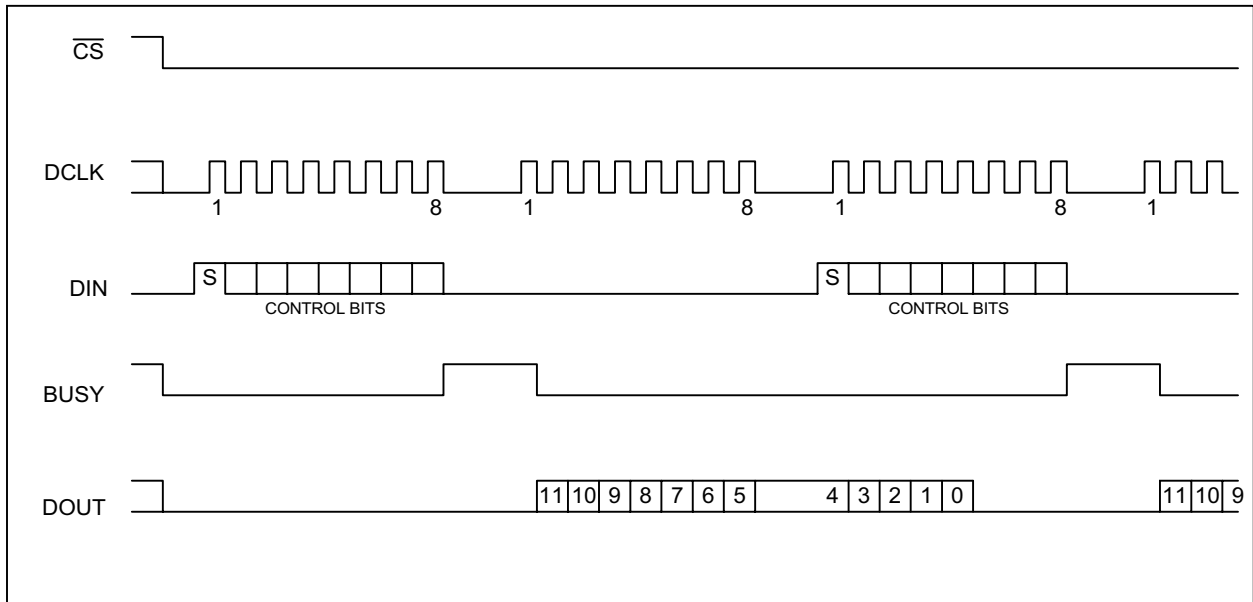

FIGURE 10. Conversion Timing , 16-Clocks per Conversion , 8-bit Bus Interface. No DCLK Delay Required with Dedicated Serial Port.

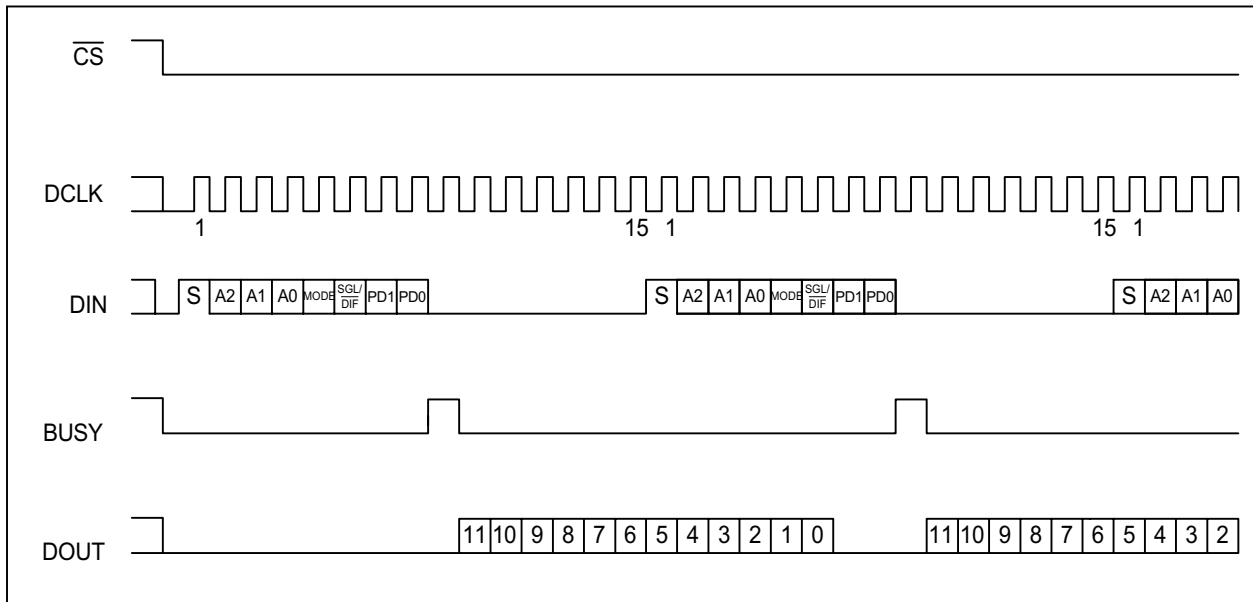

FIGURE 11. Maximum Conversion Rate , 15-Clocks per Conversion.

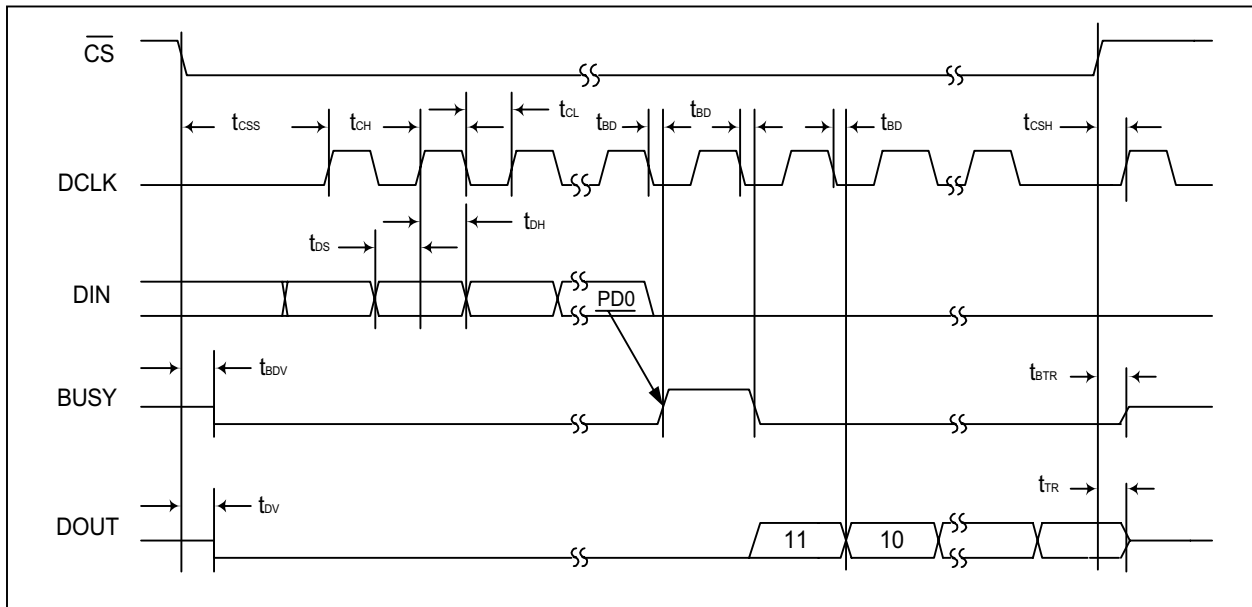

FIGURE 12. Detailed Timing Diagram.

Customer Service

Anpec Electronics Corp.

Head Office :

5F, No. 2 Li-Hsin Road, SBIP,
Hsin-Chu, Taiwan, R.O.C.
Tel : 886-3-5642000
Fax : 886-3-5642050

Taipei Branch :

7F, No. 137, Lane 235, Pac Chiao Rd.,
Hsin Tien City, Taipei Hsien, Taiwan, R. O. C.
Tel : 886-2-89191368
Fax : 886-2-89191369

Packaging Information

SSOP

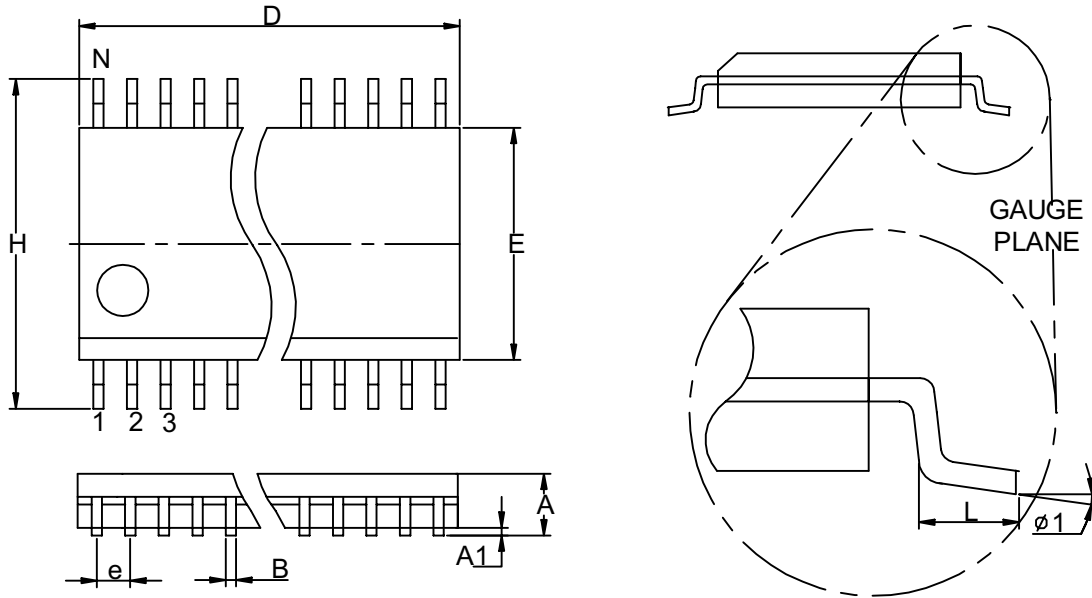

Dim	Millimeters		Variations- D			Dim	Inches		Variations- D		
	Min.	Max.	Variations	Min.	Max.		Min.	Max.	Variations	Min.	Max.
A	1.350	1.75	SSOP-16	4.75	5.05	A	0.053	0.069	SSOP-16	0.187	0.199
A1	0.10	0.25				A1	0.004	0.010			
B	0.20	0.30				B	0.008	0.012			
D	See variations					D	See variations				
E	3.75	4.05				E	0.147	0.160			
e	0.625 TYP.					e	0.025 TYP.				
H	5.75	6.25				H	0.226	0.246			
L	0.4	1.27				L	0.016	0.050			
N	See variations					N	See variations				
$\phi 1$	0°	8°				$\phi 1$	0°	8°			

Packaging Information

TSSOP

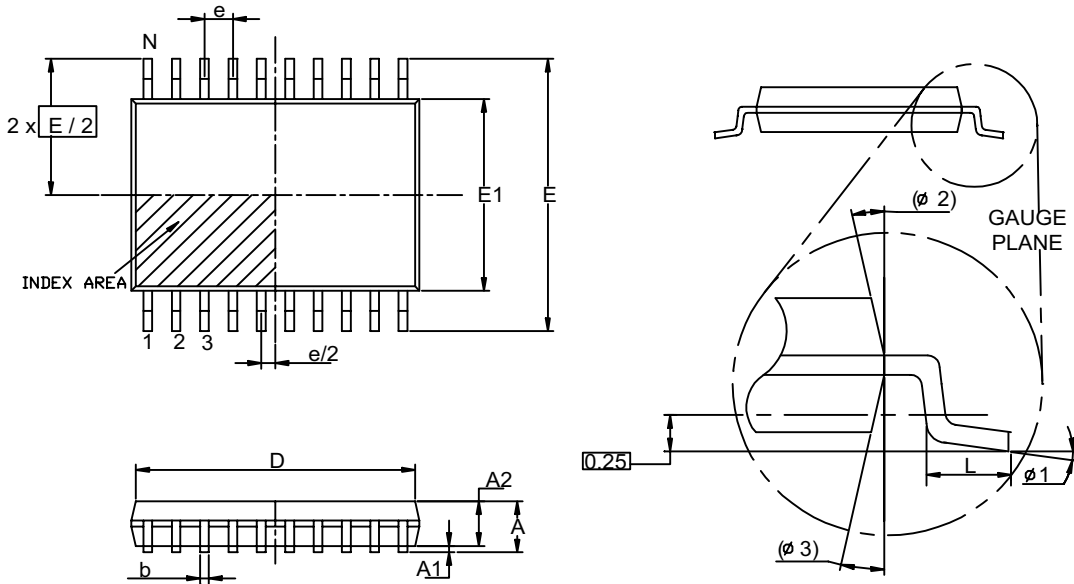

Dim	Millimeters		Inches	
	Min.	Max.	Min.	Max.
A		1.2		0.047
A1	0.00	0.15	0.000	0.006
A2	0.80	1.05	0.031	0.041
b	0.19	0.30	0.007	0.011
D	4.9 (N=16PIN)	5.1 (N=16PIN)	0.193 (N=16PIN)	0.201 (N=16PIN)
	6.4 (N=20PIN)	6.6 (N=20PIN)	0.252 (N=20PIN)	0.260 (N=20PIN)
	7.7 (N=24PIN)	7.9 (N=24PIN)	0.303 (N=24PIN)	0.311 (N=24PIN)
	9.6 (N=28PIN)	9.8 (N=28PIN)	0.378 (N=28PIN)	0.386 (N=28PIN)
e	0.65 BSC		0.026 BSC	
E	6.40 BSC		0.252 BSC	
E1	4.30	4.50	0.169	0.177
L	0.45	0.75	0.018	0.030
$\phi 1$	0°	8°	0°	8°
$\phi 2$	12° REF		12° REF	
$\phi 3$	12° REF		12° REF	