

# MITSUBISHI MICROCOMPUTERS

## M37413M4-XXXFP

### SINGLE-CHIP 8-BIT CMOS MICROCOMPUTER

#### DESCRIPTION

The M37413M4-XXXFP is a single-chip microcomputer designed with CMOS silicon gate technology. It is housed in a 80-pin plastic molded QFP. This single-chip microcomputer is useful for business equipment and other consumer applications.

In addition to its simple instruction set, the ROM, RAM, and I/O addresses are placed on the same memory map to enable easy programming.

#### FEATURES

- Number of basic instructions..... 69
- Memory size ROM..... 8192 bytes  
RAM..... 256 bytes
- Instruction execution time (minimum instructions)  
at high-speed mode.....  $1\mu\text{s}$   
at low-speed mode.....  $4\mu\text{s}$
- Single power supply  
 $f(X_{IN})=8\text{MHz}$ .....  $4.5\sim 5.5\text{V}$   
 $f(X_{IN})=2\text{MHz}$ .....  $2.5\sim 5.5\text{V}$
- Power dissipation  
normal operation mode (at 8MHz frequency)  
.....  $30\text{mW}$  ( $V_{CC}=5\text{V}$ , Typ.)  
low-speed operation mode (at 32kHz frequency for  
clock function).....  $54\mu\text{W}$  ( $V_{CC}=3\text{V}$ , Typ.)
- RAM retention voltage (stop mode)  
.....  $2.0\text{V}\leq V_{RAM}\leq 5.5\text{V}$
- Subroutine nesting..... 96levels (Max.)
- Interrupt..... 10types, 5vectors
- 8-bit timer..... 4 (3 when used as serial I/O)
- 16-bit timer..... 1
- Programmable I/O ports  
(Ports P0, P1, P2, P3, P5, P6, P7)..... 56
- Input port (Port P4)..... 8
- Serial I/O (8-bit)..... 1
- A-D converter..... 8-bit, 8channel  
conversion speed ( $25\mu\text{s}$ )
- Two clock generating circuits  
(One is for main clock, the other is for clock function)

#### APPLICATION

Audio-visual equipment, VCR, Tuner, Office automation equipment, Camera

#### PIN CONFIGURATION (TOP VIEW)

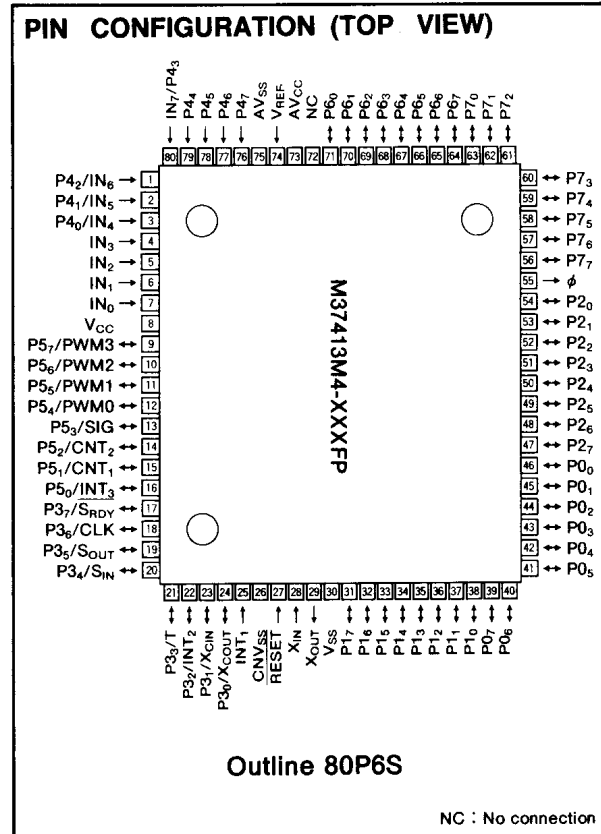

M37413M4-XXXFP BLOCK DIAGRAM

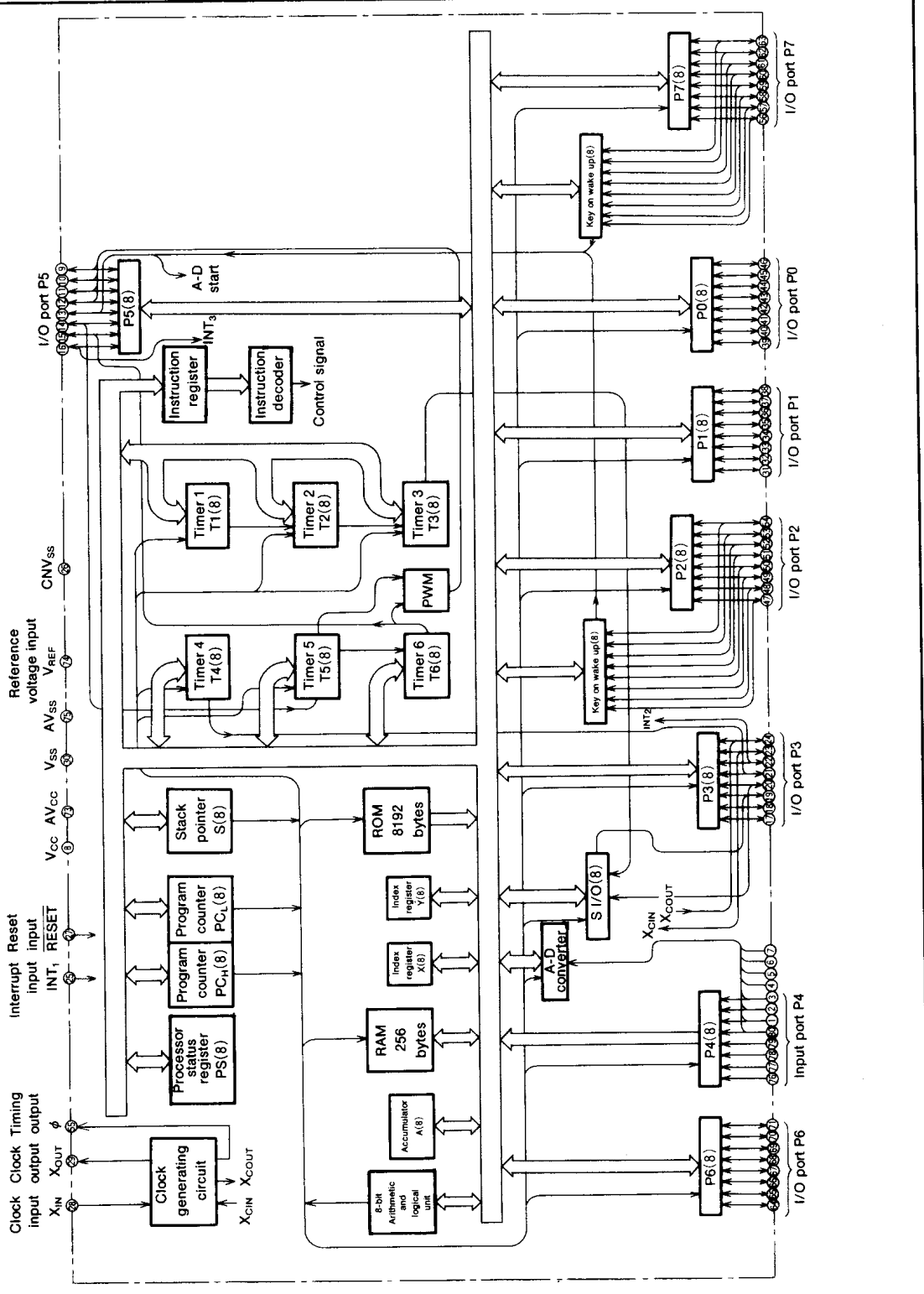

**SINGLE-CHIP 8-BIT CMOS MICROCOMPUTER**

**FUNCTIONS OF M37413M4-XXXFP**

Parameter		Functions
Number of basic instructions		69
Instruction execution time		1 $\mu$ s (minimum instructions, at 8MHz frequency).
Clock frequency		8MHz (at V <sub>CC</sub> =5V $\pm$ 10%)
Memory size	ROM	8192bytes
	RAM	256bytes
Input/Output port	P0, P2, P7	I/O
	P1, P3, P5, P6	I/O
	P4	Input
Serial I/O		8-bitX1
Timers		8-bit timerX4 16-bit timerX1
Subroutine nesting		96 (max)
Interrupt		Three external interrupts, three timer interrupts, serial I/O interrupt, A-D interrupt, key on wake up, one software interrupt
Clock generating circuit		Two built-in circuits (ceramic or quartz crystal oscillator )
Operating temperature range		-20~75 $^{\circ}$ C
Device structure		CMOS silicon gate
Package		80-pin plastic molded QFP

**MITSUBISHI MICROCOMPUTERS**  
**M37413M4-XXXFP**

**SINGLE-CHIP 8-BIT CMOS MICROCOMPUTER**

**PIN DESCRIPTION**

Pin	Name	Input/ Output	Functions
V <sub>CC</sub> , V <sub>SS</sub>	Supply voltage		Power supply inputs 5V±10% to V <sub>CC</sub> , and 0V to V <sub>SS</sub> .
CNV <sub>SS</sub>	CNV <sub>SS</sub>		This is connect to V <sub>SS</sub> .
RESET	Reset input	Input	To enter the reset state, the reset input pin must be kept at a "L" for more than 16μs (under normal V <sub>CC</sub> conditions). If more time is needed for the crystal oscillator to stabilize, this "L" condition should be maintained for the required time.
X <sub>IN</sub>	Clock input	Input	These are I/O pins of internal clock generating circuit for main clock. To control generating frequency, an external ceramic or a quartz crystal oscillator is connected between the X <sub>IN</sub> and X <sub>OUT</sub> pins. If an external clock is used, the clock source should be connected the X <sub>IN</sub> pin and the X <sub>OUT</sub> pin should be left open.
X <sub>OUT</sub>	Clock output	Output	
INT <sub>1</sub>	Interrupt input	Input	This is the highest order interrupt input pin.
AV <sub>CC</sub>	Voltage input for A-D		This is power supply input pin for the A-D converter.
AV <sub>SS</sub>	Voltage input for A-D		This is GND input pin for the A-D converters.
V <sub>REF</sub>	Reference voltage input	Input	This is reference voltage input pin for the A-D converter.
P0 <sub>0</sub> ~P0 <sub>7</sub>	I/O port P0	I/O	Port P0 is an 8-bit I/O port with directional registers allowing each I/O bit to be individually programmed as input or output. At reset, this port is set to input mode. The output structure is CMOS output.
P1 <sub>0</sub> ~P1 <sub>7</sub>	I/O port P1	I/O	Port P1 is an 8-bit I/O port and has basically the same functions as port P0, but the output structure is N-ch open drain.
P2 <sub>0</sub> ~P2 <sub>7</sub>	I/O port P2	I/O	Port P2 is an 8-bit I/O port and has basically the same functions as port P0 and also works as the key on wake up function with mask option.
P3 <sub>0</sub> ~P3 <sub>7</sub>	I/O port P3	I/O	Port P3 is an 8-bit I/O port and has basically the same functions as port P1. When serial I/O is used, P3 <sub>7</sub> , P3 <sub>6</sub> , P3 <sub>5</sub> , and P3 <sub>4</sub> work as S <sub>RDY</sub> , CLK, S <sub>OUT</sub> , and S <sub>IN</sub> pins, respectively. Also P3 <sub>3</sub> , P3 <sub>2</sub> , P3 <sub>1</sub> , and P3 <sub>0</sub> work as timer 4 overflow signal divided by 2 output pin (T), INT <sub>2</sub> pin, X <sub>CIN</sub> and X <sub>COU</sub> T pins, respectively.
P4 <sub>0</sub> ~P4 <sub>7</sub>	Input port P4	input	Port P4 is an 4-bit input port. P4 <sub>0</sub> ~P4 <sub>3</sub> are in common with IN <sub>4</sub> ~IN <sub>7</sub> .
P5 <sub>0</sub> ~P5 <sub>7</sub>	I/O port P5	I/O	Port P5 is an 8-bit I/O port and has basically the same function as P1. P5 <sub>0</sub> , P5 <sub>1</sub> , P5 <sub>2</sub> and P5 <sub>3</sub> are in common with INT <sub>3</sub> , timer3 input, timer5 input and A-D trigger input respectively. P5 <sub>4</sub> ~P5 <sub>7</sub> are also in common with PWM0~PWM3.
P6 <sub>0</sub> ~P6 <sub>7</sub>	I/O port P6	I/O	Port P6 is an 8-bit I/O port and has basically the same functions as port P1.
P7 <sub>0</sub> ~P7 <sub>7</sub>	I/O port P7	I/O	Port P7 is an 8-bit I/O port and has basically the same functions as port P2.

SINGLE-CHIP 8-BIT CMOS MICROCOMPUTER

BASIC FUNCTION BLOCKS

MEMORY

A memory map for the M37413M4-XXXFP is shown in Figure 1. Addresses 2000<sub>16</sub> to 3FFF<sub>16</sub> are assigned for the built-in ROM area which consists of 8192 bytes. Addresses 3F00<sub>16</sub> to 3FFF<sub>16</sub> are a special address area (special page). By using the special page addressing mode of JSR instruction, subroutines addressed on this page can be called with only 2 bytes. Addresses 3FF4<sub>16</sub> to 3FFF<sub>16</sub> are vector addresses used for reset and interrupts (see interrupts

chapter). Addresses 0000<sub>16</sub> to 00FF<sub>16</sub> are the zero page address area. By using zero page addressing mode, this area can also be accessed with 2 bytes. The use of these addressing methods will greatly reduce the object size required.

The RAM, I/O port, timer, etc. addresses are already assigned for the zero page. Addresses 0000<sub>16</sub> to 00BF<sub>16</sub> and 0100<sub>16</sub> to 013F<sub>16</sub> are assigned for the built-in RAM which consists of 256 bytes. This RAM is used as the stack during subroutine calls and interrupts, in addition to data storage.

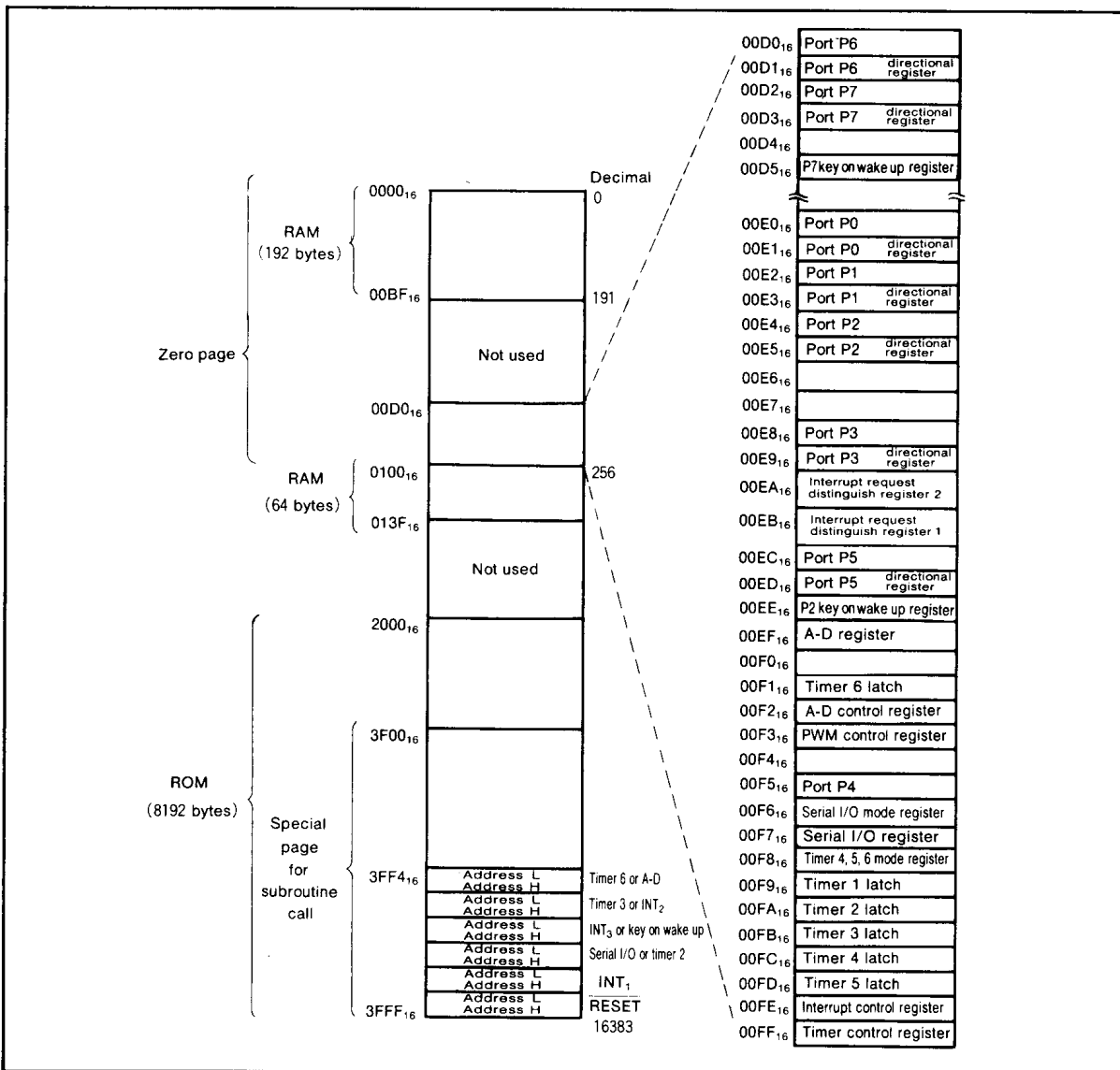

Fig. 1 Memory map

**MITSUBISHI MICROCOMPUTERS**  
**M37413M4-XXXFP**

**SINGLE-CHIP 8-BIT CMOS MICROCOMPUTER**

**CENTRAL PROCESSING UNIT (CPU)**

The CPU consists of 6 registers and is shown in Figure 2.

**ACCUMULATOR (A)**

The 8-bit accumulator (A) is the main register of the micro-computer. Data operations such as data transfer, input/output, etc., is executed mainly through the accumulator.

**INDEX REGISTER X (X)**

The index register X is an 8-bit register. In the index register X addressing mode, the value of the OPERAND added to the contents of the index register X specifies the real address. When the T flag in the processor status register is set to "1", the index register X itself becomes the address for the second OPERAND.

**INDEX REGISTER Y (Y)**

The index register Y is an 8-bit register. In the index register Y addressing mode, the value of the OPERAND added to the contents of the index register Y specifies the real address.

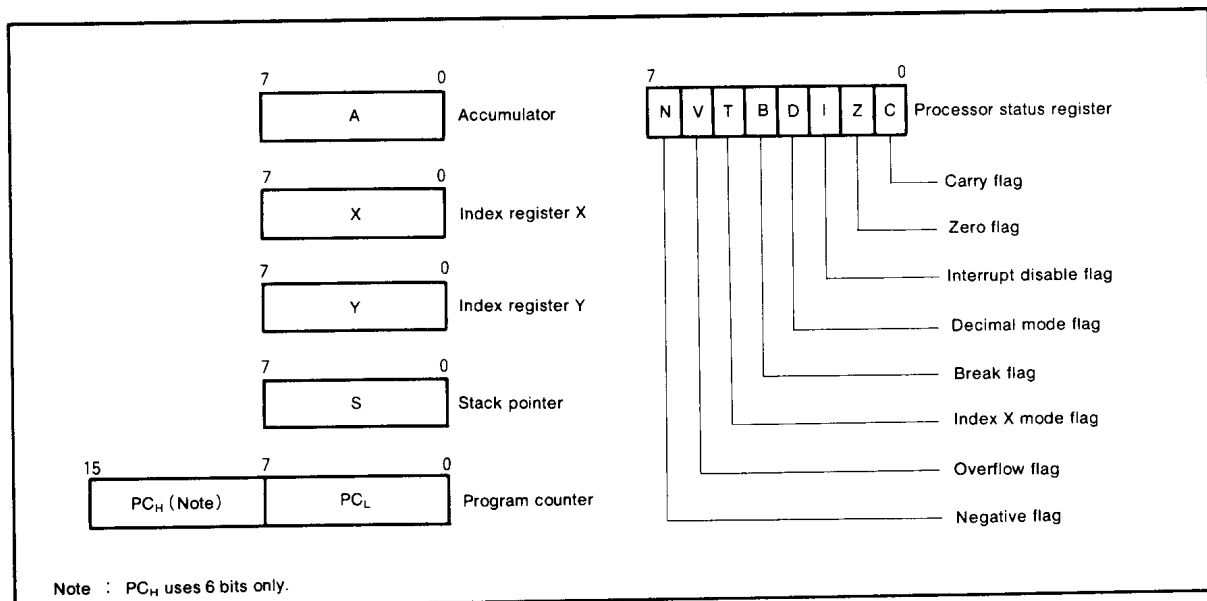

**Fig. 2 Register structure**

SINGLE-CHIP 8-BIT CMOS MICROCOMPUTER

### STACK POINTER (S)

The stack pointer is an 8-bit register that contains the address of the next location in the stack. It is mainly used during interrupts and subroutine calls. The stack pointer is not automatically initialized after reset and should be initialized by the program using the TXS instruction.

When an interrupt occurs, the higher 8-bit of the program counter is pushed into the stack first, the stack pointer is decremented, and then the lower 8-bits of the program counter is pushed into the stack. Next the contents of the processor status register is pushed into the stack. When the return from interrupt instruction (RTI) is executed, the program counter and processor status register data is popped off the stack in reverse order from above.

The accumulator is never pushed into the stack automatically, so a push accumulator instruction (PHA) is provided to execute this function. Restoring the accumulator to its previous value is accomplished by the pop accumulator instruction (PLA). It is executed in the reverse order of the PHA instruction.

The contents of the processor status register (PS) are pushed and popped to and from the stack with the PHP and PLP instructions, respectively.

During a subroutine call, only the program counter is pushed into the stack. Therefore, any registers that should not be destroyed should be pushed into the stack manually. To return from a subroutine call, the RTS instruction is used.

### PROGRAM COUNTER (PC)

The 16-bit program counter consists of two 8-bit registers PC<sub>H</sub> and PC<sub>L</sub>. The program counter is used to indicate the address of the next instruction to be executed.

PC<sub>H</sub> is used 6 bits.

### PROCESSOR STATUS REGISTER (PS)

The 8-bit PS is composed entirely of flags used to indicate the condition of the processor immediately after an operation. Branch operations can be performed by testing the Carry flag (C), Zero flag (Z), Overflow flag (V) or the Negative flag (N). Each bit of the register is explained below.

#### 1. Carry flag (C)

The carry flag contains the carry or borrow generated by the Arithmetic and Logical operation Unit (ALU) immediately after an operation. It is also changed by the shift and rotate instructions. The set carry (SEC) and clear carry (CLC) instructions allow direct access for setting clearing this flag.

#### 2. Zero flag (Z)

This flag is used to indicate if the immediated operation generated a zero result or not. If the result is zero, the zero flag will be set to "0". If the result is not zero, the zero flag

will be set to "1".

#### 3. Interrupt disable flag (I)

This flag is used to disable all interrupts. This is accomplished by setting the flag to "1". When an interrupt is accepted, this flag is automatically set to "1" to prevent from other interrupts until the current interrupt is completed. The SEI and CLI instructions are used to set and clear this flag, respectively.

#### 4. Decimal mode flag (D)

The decimal mode flag is used to define whether addition and subtraction are executed in binary or decimal. If the decimal mode flag is set to "1", the operations are executed in decimal, if the flag is "0", the operations are executed in binary. Decimal correction is automatically executed. The SED and CLD instructions are used to set and clear this flag, respectively.

#### 5. Break flag (B)

When the BRK instruction is executed, the same operations are performed as in an interrupt. The address of the interrupt vector of the BRK instruction is the same as that of the lowest priority interrupt. The contents of the B flag can be checked to determine which condition caused the interrupt. If the BRK instruction caused the interrupt, the B flag will be "1", otherwise, it will be "0".

#### 6. Index X mode flag (T)

When the T flag is "1", operations between memories are executed directly, without passing through the accumulator. Operations between memories involving the accumulator are executed when the T flag is "0" (i.e., operation results between memories 1 and 2 are stored in the accumulator). The address of memory 1 is specified by the contents of the index register X, and that of memory 2 is specified by the normal addressing mode. The SET and CLT instructions are used to set and clear the T flag, respectively.

#### 7. Overflow flag (V)

The overflow flag functions when one byte is added or subtracted as a signed binary number. When the result exceeds +127 or -128, the overflow flag is set to "1". When the BIT instruction is executed, bit 6 of the memory location is input to the V flag. The overflow flag is clear by the CLV instruction and there is no set instruction.

#### 8. Negative flag (N)

The negative flag is set whenever the result of a data transfer or operation is negative (bit 7 is "1"). Whenever the BIT instruction is executed, bit 7 of the memory location is input to the N flag. There are no instructions for directly setting or clearing the N flag.

SINGLE-CHIP 8-BIT CMOS MICROCOMPUTER

**INTERRUPT**

The M37413M4-XXXFP can be interrupted from ten sources; INT<sub>1</sub>, Timer 2 or Serial I/O, INT<sub>3</sub> or Key on wake up, INT<sub>2</sub> or Timer 3, Timer 6 or A-D, and BRK instruction.

"Key on wake up" can only be used at power down state by STP instruction or WIT instruction. When one of the P2 or P7 is "L", an interrupt occurs.

These interrupts are vectored and their priorities are shown in Table 1. Reset is included in this table since it has the same function as an interrupt.

When an interrupt is accepted, the contents of certain registers are pushed into specified locations, as discussed in the stack pointer section, and the interrupt disable flag (I) is set, and the program jumps to the address specified by the interrupt vector, and the interrupt request bit is cleared automatically. The reset interrupt is the highest priority interrupt and can never be inhibited. Except for the reset interrupt, all interrupts are inhibited when the interrupt disable flag is set to "1". All of the other interrupts can further be controlled individually via the interrupt control register shown in Figure 3. An interrupt is accepted when the interrupt enable bit and the interrupt request bit are both "1" and the interrupt disable flag is "0".

The interrupt request bits are set when the following conditions occur:

- (1) When the INT<sub>1</sub>, INT<sub>2</sub> or INT<sub>3</sub> pins go from "H" to "L" or "L" to "H"
- (2) When the levels any pin of P2 or P7 goes "L" (at power down mode)
- (3) When the contents of timer 2, timer 3, timer 6 or the counter of serial I/O goes "0"

When the two interrupt requests, which are the same priority and are at the same sampling, the priority process is processed by interrupt request distinguish register 1 and 2. These request bits can be clear by a program but can not be set. The interrupt enable bit can be set and clear by a program. Since the BRK instruction interrupt and the timer 6 or A-D, interrupt have the same vectored address, the contents of the B flag must be checked to determine if the BRK instruction caused the interrupt or if timer 6 or A-D generated the interrupt.

Table 1. Interrupt vector address and priority.

Interrupt	Priority	Vector address
RESET	1	3FFF <sub>16</sub> , 3FFE <sub>16</sub>
INT <sub>1</sub>	2	3FFD <sub>16</sub> , 3FFC <sub>16</sub>
Serial I/O or timer 2	3	3FFB <sub>16</sub> , 3FFA <sub>16</sub>
INT <sub>3</sub> or key on wake up	4	3FF9 <sub>16</sub> , 3FF8 <sub>16</sub>
INT <sub>2</sub> or timer 3	5	3FF7 <sub>16</sub> , 3FF6 <sub>16</sub>
Timer 6 or A-D (BRK)	6	3FF5 <sub>16</sub> , 3FF4 <sub>16</sub>

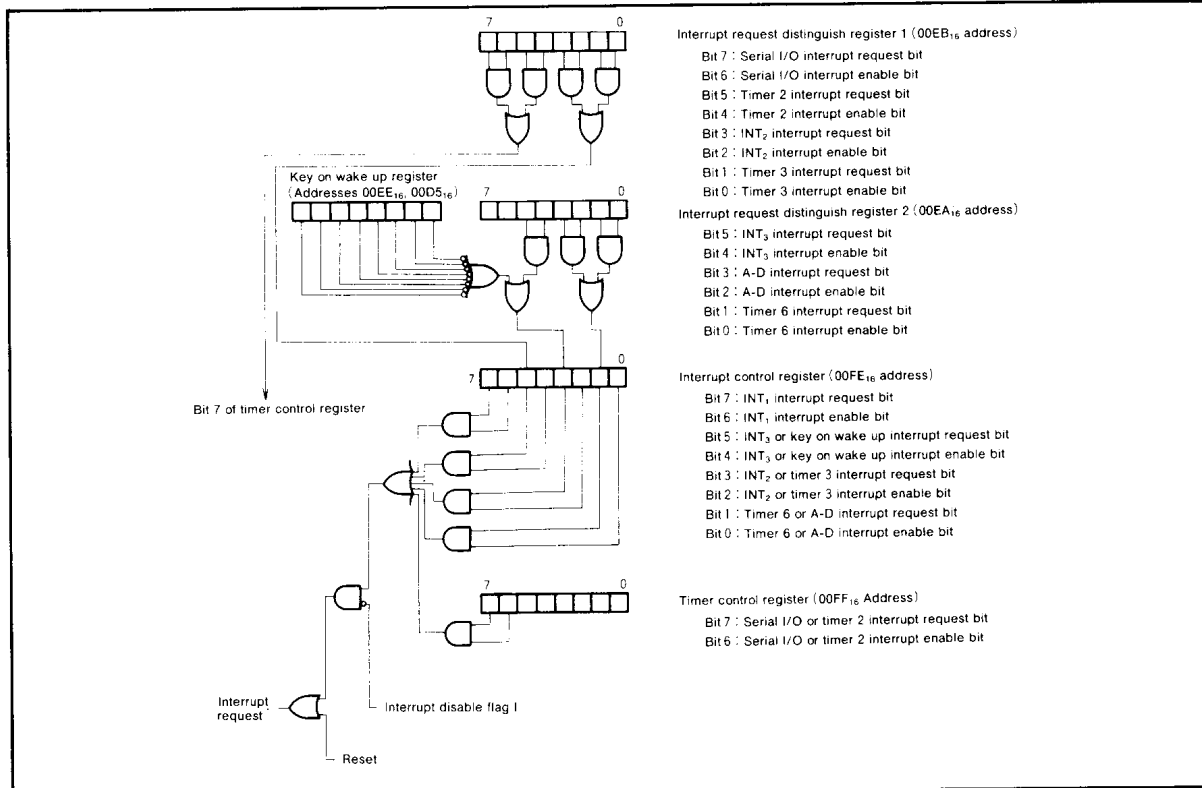



SINGLE-CHIP 8-BIT CMOS MICROCOMPUTER

## TIMER

The M37413M4-XXXFP has six timers; timer 1, timer 2, timer 3, timer 4, timer 5 and timer 6.

A block diagram of timer1 through 6 is shown in Figure 4.

The count source for timer 1 through 3 can be selected by using bit 2, 3, 4 and 5 of the timer control register (address  $00FF_{16}$ ), as shown in Figure 5. All of the timers are down count timers and have 8-bit latches. When a timer reaches "0" and the next count pulse is input to a timer, the contents of the reload latch are loaded into the timer. The division ratio of the timer is  $1/(n+1)$ , where n is the contents of timer latch.

Timer 2, 3 and 6 has interrupt generating functions. The timer interrupt request bit which is in the interrupt distinguish register 1 or 2 (located at addresses  $00EB_{16}$  and  $00EA_{16}$  respectively) is set at the next count pulse after the timer reaches "0" (see interrupt section).

The starting and stopping of timer1 is controlled by bit 7 of the interrupt distinguish register 2, timer 3 by bit 6 of the interrupt distinguish register 2 and timer 4 by bit 3 of timer 4, 5 and 6 mode register ( $00F8_{16}$  address). If the corresponding bit is "0", the timer starts counting, and the corresponding bit is "1", the timer stops. The timer4 overflow signal divided by 2 can be outputted from port  $P3_3$  by setting the bit 4 of the serial I/O mode register ( $00F6_{16}$  address) to "1".

Timer 5 and 6 work as timer mode, event counter mode and PWM mode by changing the contents of bit 5 and bit 6 of the timer 4, 5 and 6 mode register.

### (1) Timer Mode

This mode is the 16-bit timer, and the count source is  $\phi/4$ . When the bit 6 of PWM control register ( $00F3_{16}$  address) is "1", the timer6 overflow signal divided by 2 is output from  $CNT_2$  pin (common with  $P5_2$ ).

### (2) Event Counter Mode

The count source is input from the  $CNT_2$  pin. The count decremented each time the input goes from "L" to "H".

### (3) PWM Mode

As shown in Figure 7, the output wave is controlled by the contents of the timer latch of timer 5 and 6.

PWM output can choose among PWM0, PWM1, PWM2 and PWM3 by bit 0, bit 1, bit 2 and bit 3 of PWM control register.

When the count value of all timers, from timer 1 to timer 6, are read, be careful not to change the input source.

When the count source is inputted from the external pin, the minimum pulse width should be  $8\mu s$ .

After a STP instruction is executed, timer 2, timer 1, and the clock ( $\phi$  divided by 4) are connected in series (regardless of the status of bit 2 through 5 of the timer control register). This state is canceled if timer2 interrupt request bit is set to "1", or if the system is reset. Before the STP instruction is executed, bit 7 of the interrupt request distinguish register2 (timer1 count stop bit), bit 5 of the interrupt request distinguish register1 and bit 6 and bit 7 of the timer control

register must be set to "0". And also bit 4 of the interrupt request distinguish register1 must be set to "1". For more details on the STP instruction, refer to the oscillation circuit section.

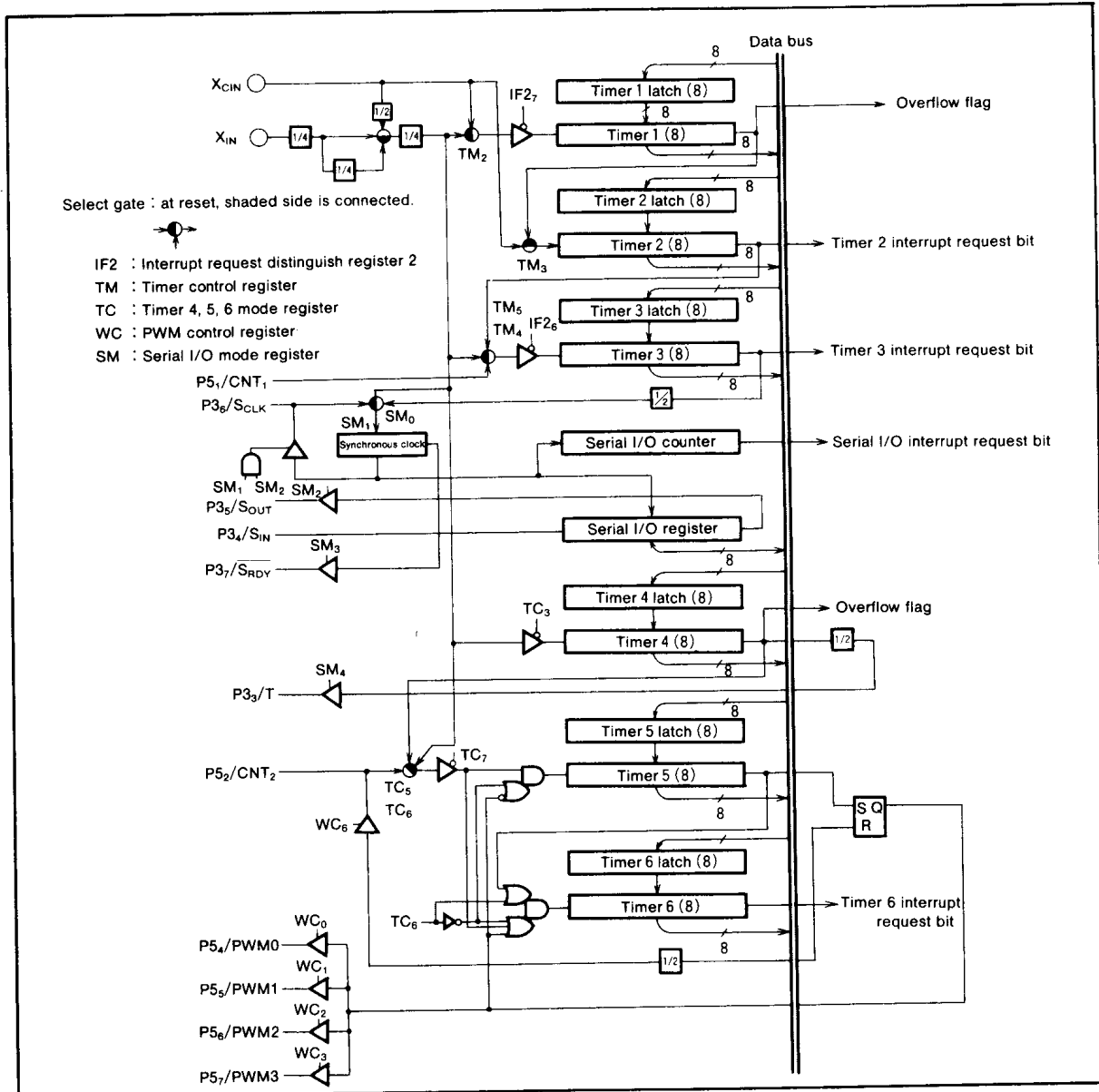

Fig. 4 Block diagram of timer 1 through 6

SINGLE-CHIP 8-BIT CMOS MICROCOMPUTER

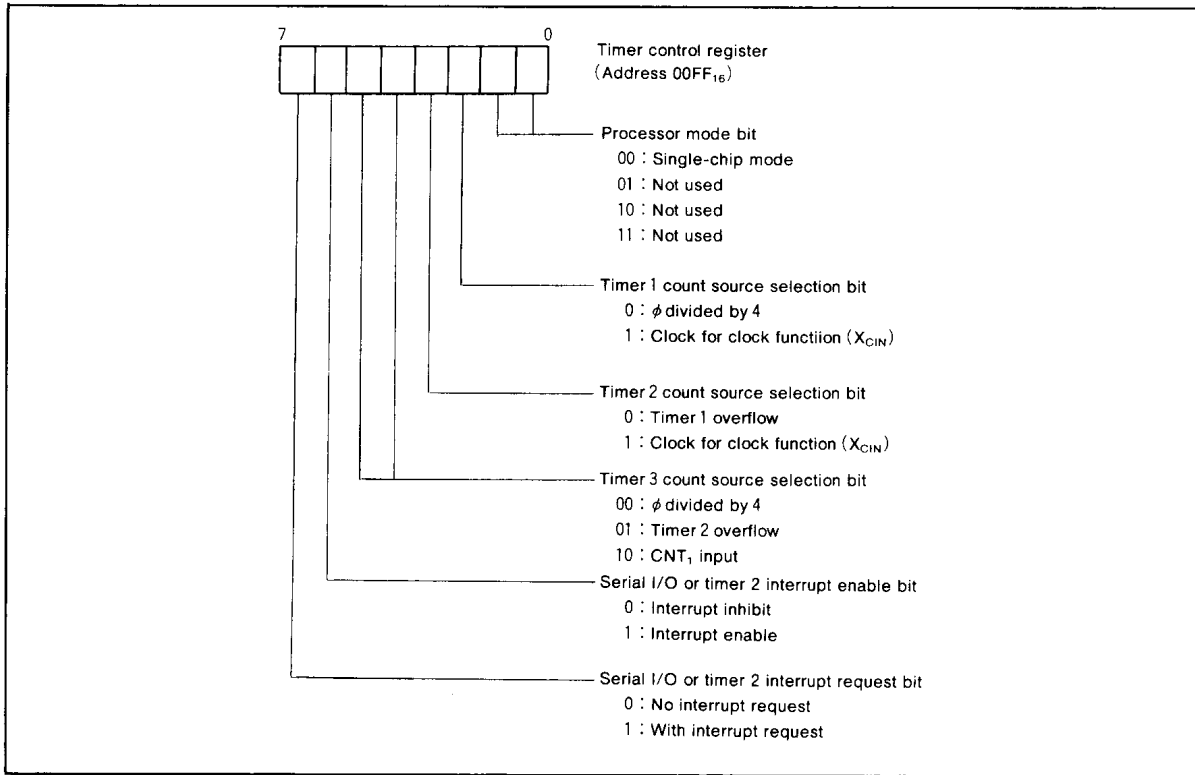

Fig. 5 Structure of timer control register

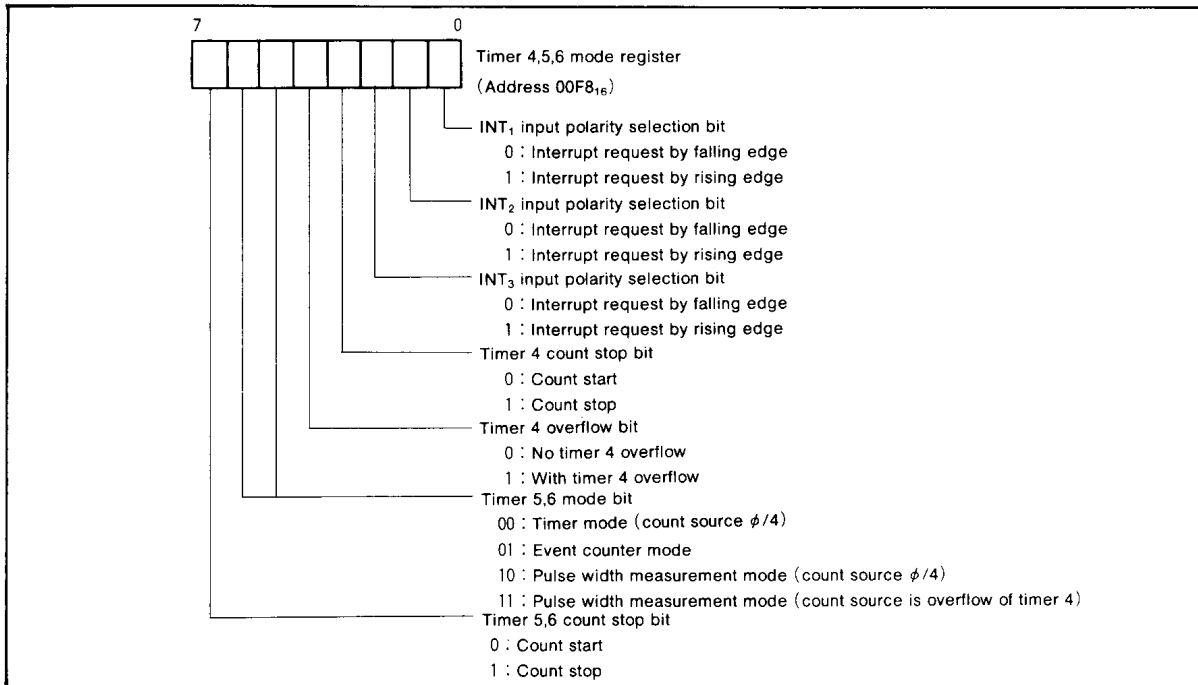

Fig. 6 Structure of timer 4,5,6 mode register

MITSUBISHI MICROCOMPUTERS  
**M37413M4-XXXFP**

**SINGLE-CHIP 8-BIT CMOS MICROCOMPUTER**

**PWM**

M37413M4-XXXFP has a pulse width modulated (PWM) output control circuit connecting with timer5 and timer6.

Figure 6 shows the structure of timer 4,5,6 mode register, Figure 7 shows the PWM rectangular wave form and Figure 8 shows the structure of PWM control register.

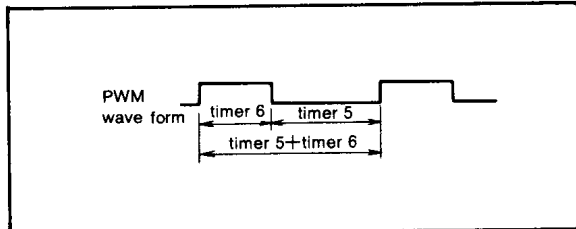

Fig. 7 PWM rectangular wave form

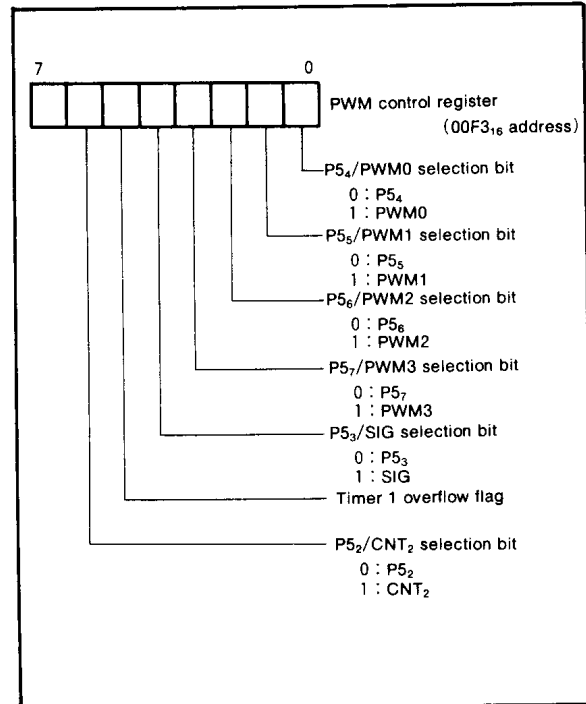

Fig. 8 Structure of PWM control register

**SINGLE-CHIP 8-BIT CMOS MICROCOMPUTER**

**SERIAL I/O**

The block diagram of serial I/O is shown in Figure 9. In the serial I/O mode the receive ready signal ( $\overline{S_{RDY}}$ ), synchronous input/output clock (CLK), and the serial I/O ( $S_{OUT}$ ,  $S_{IN}$ ) pins are used as P3<sub>7</sub>, P3<sub>6</sub>, P3<sub>5</sub>, and P3<sub>4</sub>, respectively. The serial I/O mode register (address 00F6<sub>16</sub>) is an 8-bit register. Bit 1 and 0 of this register is used to select a synchronous clock source. When these bits are [00] or [01], an external clock from P3<sub>6</sub> is selected. When these bits are [10], the overflow signal divided by two from timer 3 becomes the synchronous clock. Therefore, changing the timer period will change the transfer speed. When the bits are

[11], the internal clock  $\phi$  divided by 4 becomes the clock. Bits 2 and 3 decide whether parts of P3 will be used as a serial I/O or not. When bit 2 is "1", P3<sub>6</sub> becomes an I/O pin of the synchronous clock. When an internal synchronous clock is selected, the clock is output from P3<sub>6</sub>. If the external synchronous clock is selected, the clock is input to P3<sub>6</sub>. And P3<sub>5</sub> will be a serial output and P3<sub>4</sub> will be a serial input. To use P3<sub>4</sub> as a serial input, set the directional register bit which corresponds to P3<sub>4</sub>, to "0". For more information on the directional register, refer to the I/O pin section. To use the serial I/O, bit 2 needs to be set to "1", if it is "0" P3<sub>6</sub> will function as a normal I/O. Bit 3 determines if P3<sub>7</sub> is

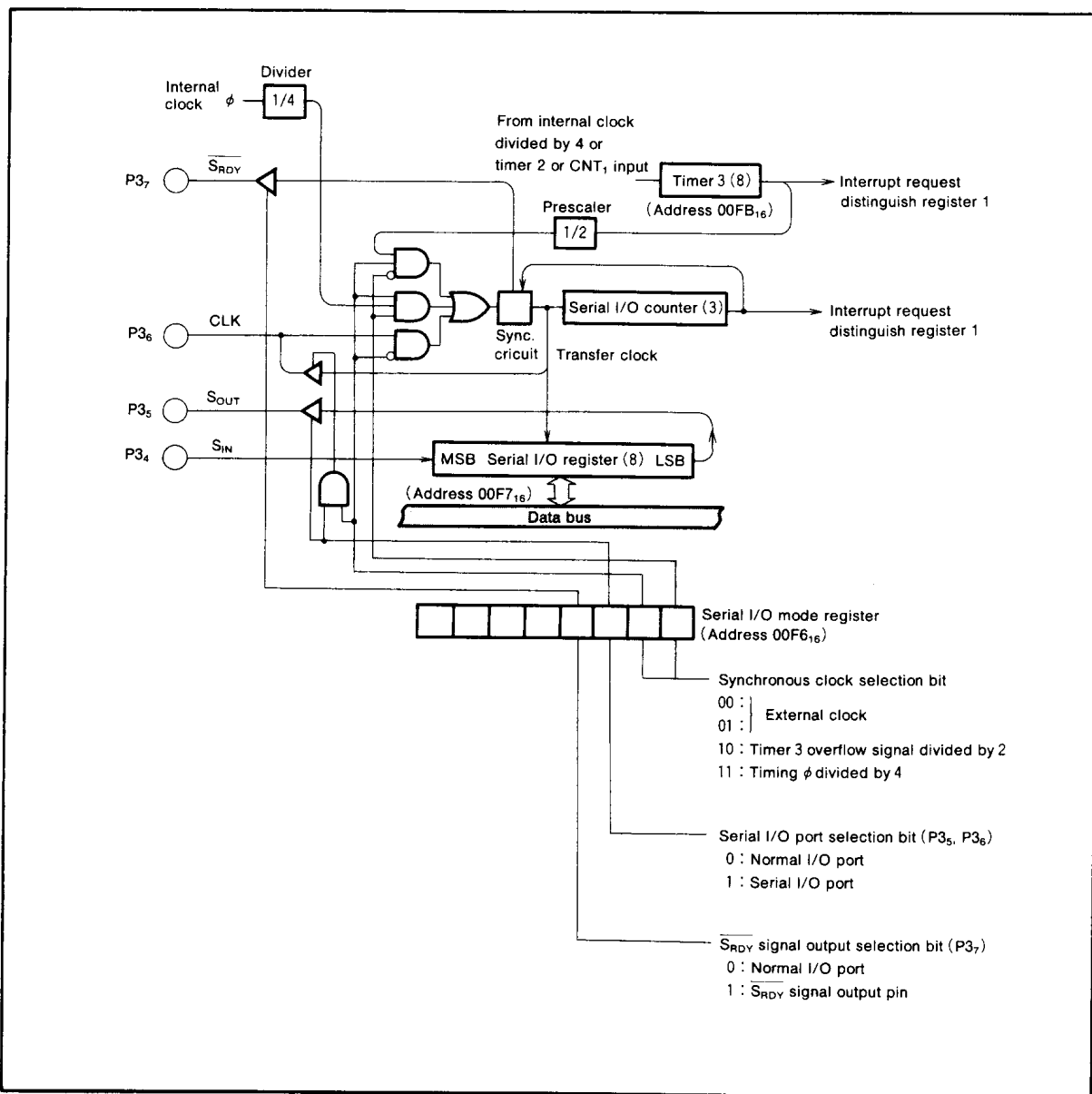

Fig. 9 Block diagram of serial I/O

**MITSUBISHI MICROCOMPUTERS**  
**M37413M4-XXXFP**

**SINGLE-CHIP 8-BIT CMOS MICROCOMPUTER**

used as an output pin for the receive data ready signal (bit 3="1",  $\overline{S_{RDY}}$ ) or used as a normal I/O pin (bit 3="0").

The function of serial I/O differs depending on the clock source; external clock or internal clock.

**Internal Clock** — The  $\overline{S_{RDY}}$  signal becomes "H" during transmission or while dummy data is stored in the serial I/O register. After the falling edge of write signal, the  $\overline{S_{RDY}}$  signal becomes low signaling that the M37413M4-XXXFP is ready to receive the external serial data. The  $\overline{S_{RDY}}$  signal goes "H" at the next falling edge of the transfer clock. The serial I/O counter is set to 7 when data is stored in the serial I/O register. At each falling edge of the transfer clock, serial data is output to P3<sub>5</sub>. During the rising edge of this clock, data can be input from P3<sub>4</sub> and the data in the serial I/O register will be shifted 1 bit. Data is output starting with

the LSB. After the transfer clock has counted 8 times, the serial I/O register will be empty and the transfer clock will remain at a high level. At this time the interrupt request bit will be set.

**External Clock** — If an external clock is used, the interrupt request bit will be set after the transfer clock has counted 8 times but the transfer clock will not stop. Due to this reason, the external clock must be controlled from the outside. The external clock should not exceed 250kHz at a duty cycle of 50%. When the external clock is chosen, the P3<sub>6</sub> pin must be held at "H" level while the serial I/O is not used.

Timing diagrams are shown in Figure 10, and connection between two M37413M4-XXXFP's are shown in Figure 11.

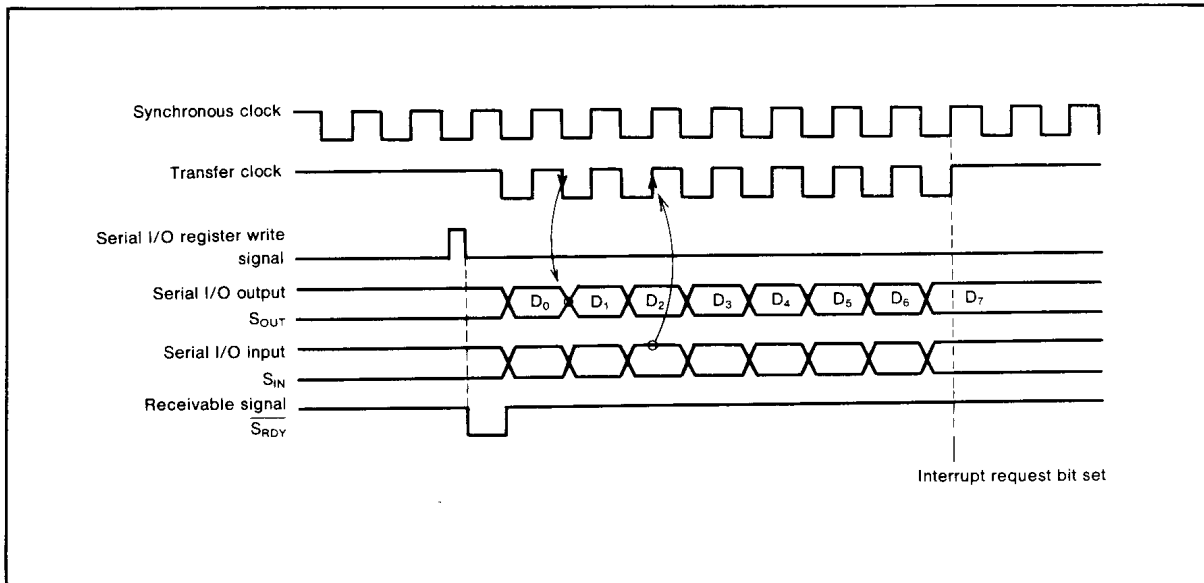

**Fig. 10 Serial I/O timing**

SINGLE-CHIP 8-BIT CMOS MICROCOMPUTER

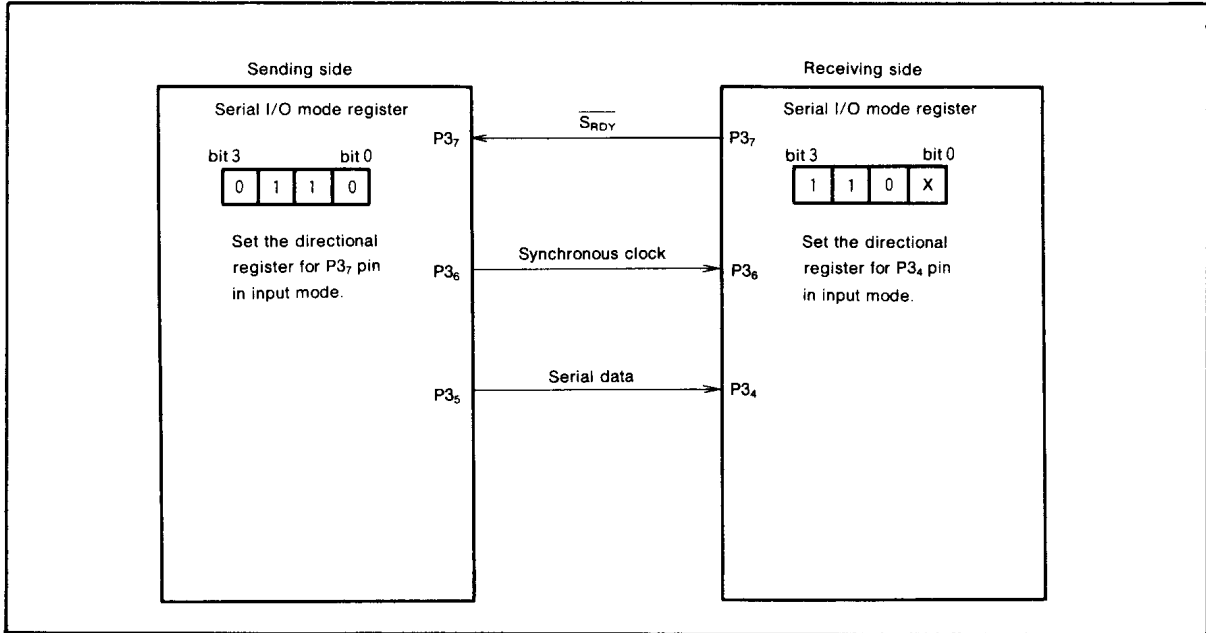

Fig. 11 Example of serial I/O connection

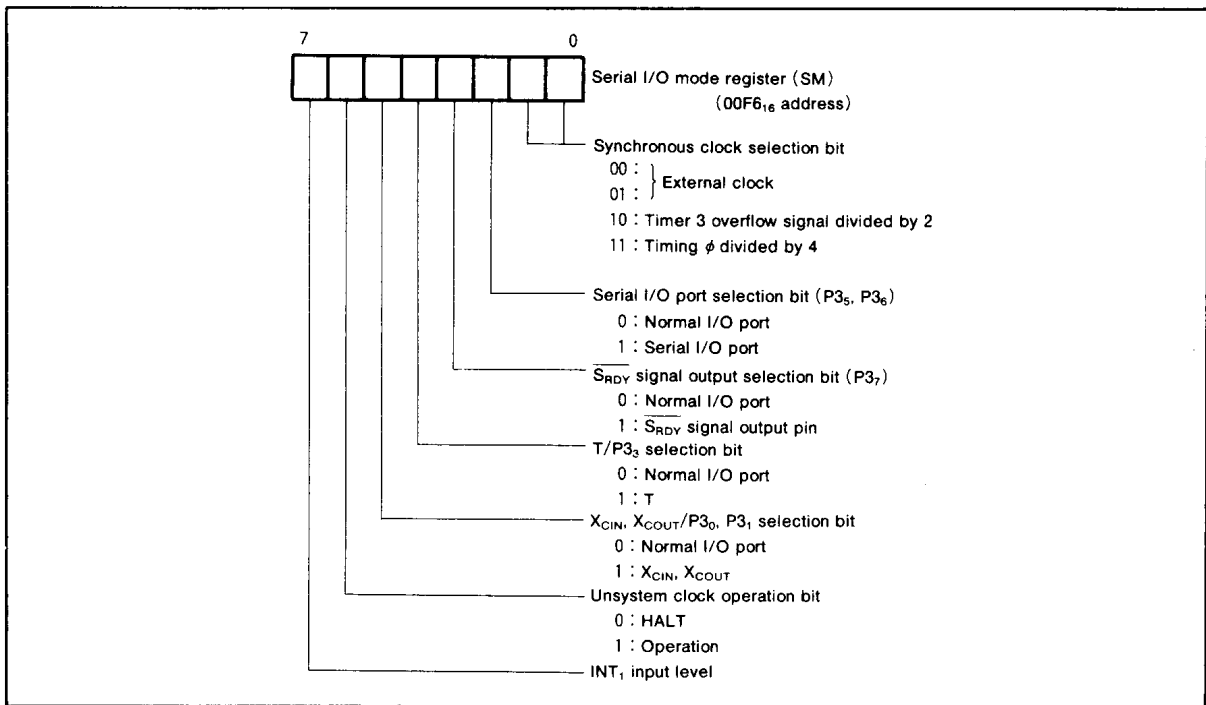

Fig. 12 Structure of serial I/O mode register

SINGLE-CHIP 8-BIT CMOS MICROCOMPUTER

**A-D CONVERTER**

The A-D converter circuit is shown in Figure 13. One of the eight analog input ports of the A-D converter ( $IN_0 \sim IN_7$ ) are selected by bits 0, 1 and 2 of the A-D control register. The  $IN$  pins, not to use as analog input, uses as input port.

Bit 0, 1 and 2, and corresponding to analog input pin is shown in Figure 14. A-D conversion is accomplished by first selecting bit 3 and 4 of the A-D control register (address  $00F2_{16}$ ) for the source of  $V_{REF}$ . And also the analog input pin is chosen by the analog input select bit of the A-D control register. A-D conversion starts by writing a dummy data to the A-D control register or changing the input level from SIG pin "H" to "L". When A-D conversion is finished, an interrupt is generated. After A-D interrupt is accepted, the result of A-D conversion can be read from the A-D register.

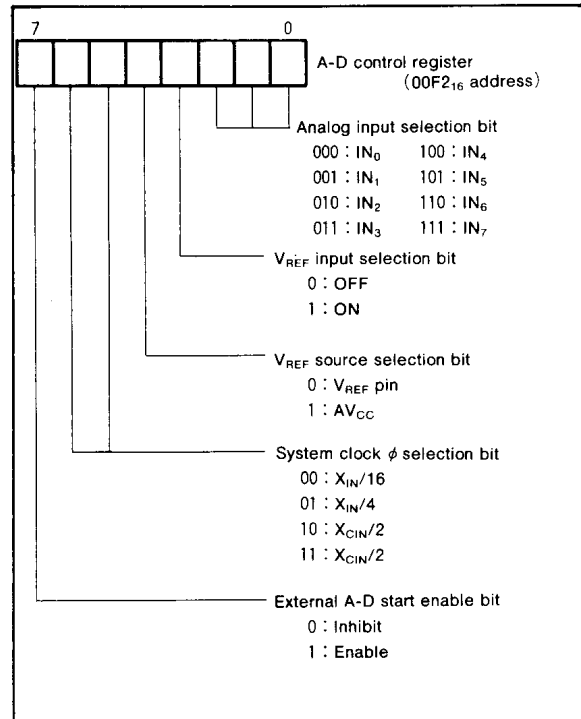

Fig. 14 Structure of segment control register

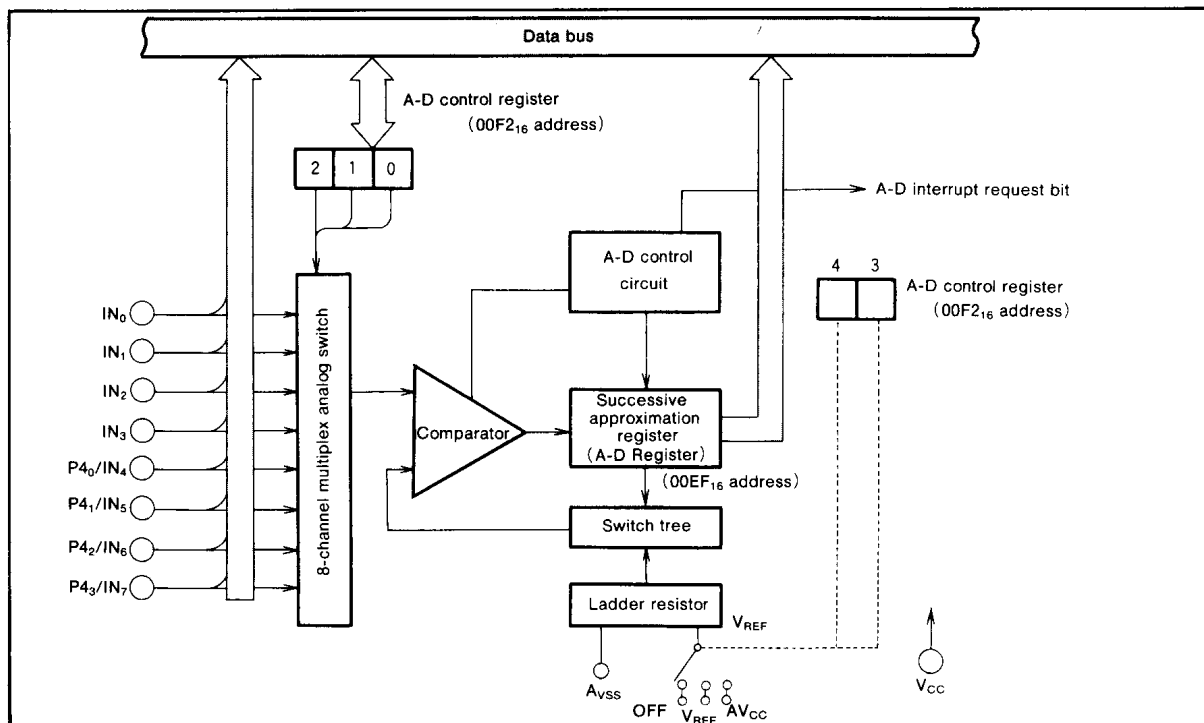

Fig. 13 A-D converter circuit



**KEY ON WAKE UP**

"Key on wake up" is one way of returning from a power down state caused by the STP or WIT instruction.

When the key on wake up option of port P2 and port P7 are designated and key on wake up interrupt enable bit (IC<sub>4</sub>) is set to "1", if the key on wake up option pin of port P2, P7 have "L" level applied, key on wake up interrupt is generated and the microcomputer is returned to the normal operating state.

When the bit 4 of PWM control register (address 00F3<sub>16</sub>) is set to "1", the pulse shown in Figure 15 is outputted from P5<sub>3</sub> pin.

As shown in Figure 16, if the key matrix of active "L" to input port P2, P7 are constructed, the microcomputer is returned to normal operating state by the key push. Refer to the section of interrupt how to use the key on wake up function. In order to enter the power down state generated by the STP or WIT instruction at the interrupt disable flag (I) is "0" and IC<sub>2</sub> is "1", the input designated as key on wake up by option in port P2, P7 must be all "H".

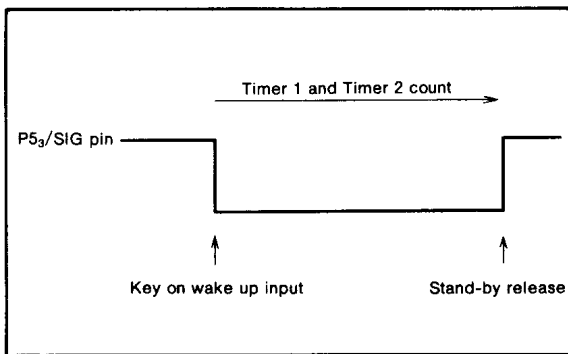

Fig. 15 Output from the SIG pin at wake up from the stop state

MITSUBISHI MICROCOMPUTERS  
**M37413M4-XXXFP**

**SINGLE-CHIP 8-BIT CMOS MICROCOMPUTER**

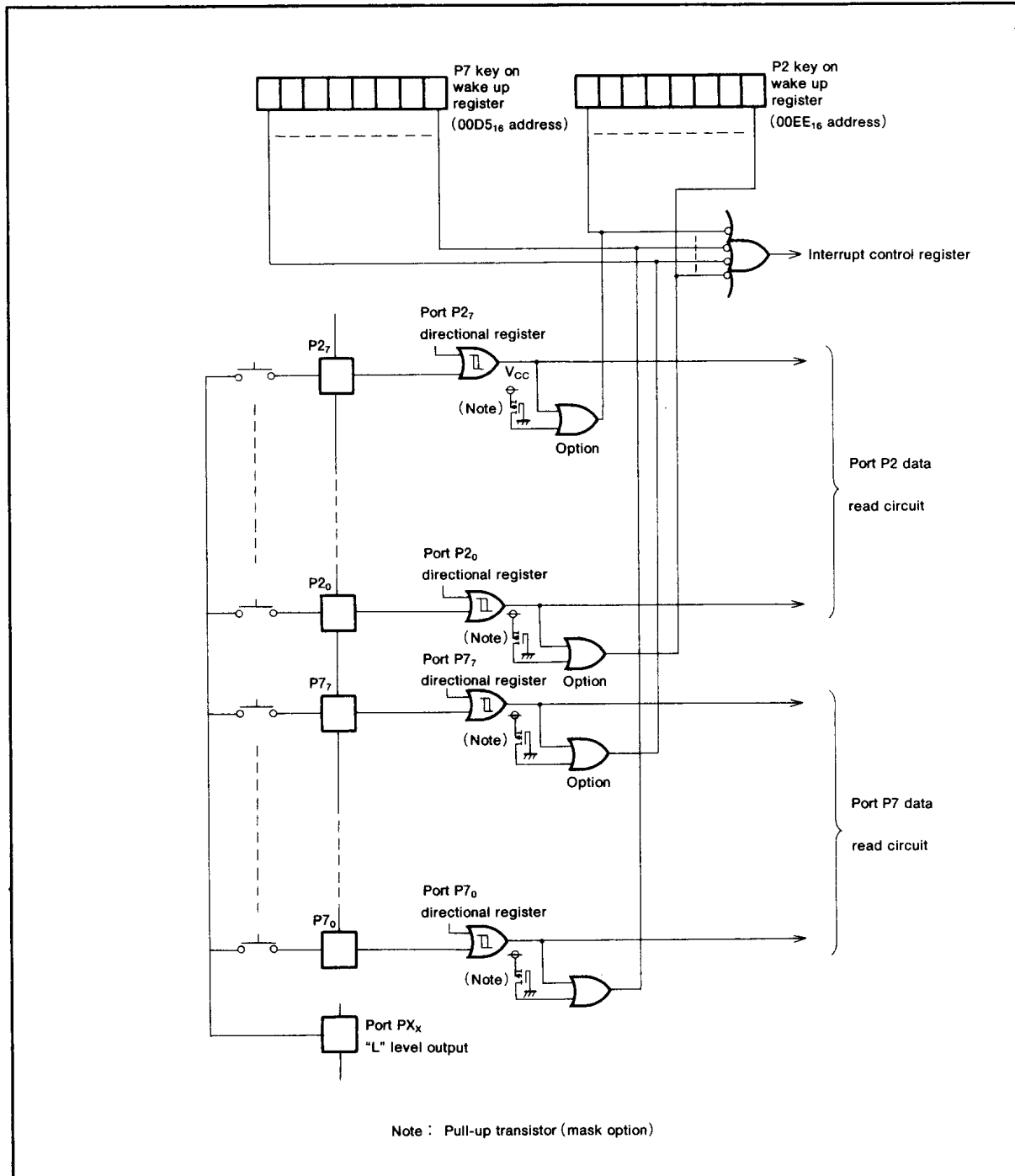

Fig. 16 Block diagram of port P2, P7 and example of wired at used key on wake up

**SINGLE-CHIP 8-BIT CMOS MICROCOMPUTER**

**RESET CIRCUIT**

The M37413M4-XXXFP is reset according to the sequence shown in Figure 19. It starts the program from the address formed by using the content of address  $3FFF_{16}$  as the high order address and the content of the address  $3FFE_{16}$  as the low order address, when the RESET pin is held at "L" level for no less than  $16 \mu s$  while the power voltage is between 4 and 5.5V and the crystal oscillator oscillation is stable and

then returned to "H" level.

The internal initializations following reset are as shown in Figure 17 regardless of the status before reset (including stop mode or wait mode).

An example of the reset circuit is shown in Figure 18.

When the power on reset is used, the RESET pin must be input "H" after the oscillation of  $X_{IN}$ - $X_{OUT}$  becomes stable.

	Address	
(1) Port P0 directional register (D0)(E1 <sub>16</sub> )...		00 <sub>16</sub>
(2) Port P1 directional register (D1)(E3 <sub>16</sub> )...		00 <sub>16</sub>
(3) Port P2 directional register (D2)(E5 <sub>16</sub> )...		00 <sub>16</sub>
(4) Port P3 directional register (D3)(E9 <sub>16</sub> )...		00 <sub>16</sub>
(5) Port P5 directional register (D5)(ED <sub>16</sub> )...		00 <sub>16</sub>
(6) Port P6 directional register (D6)(D1 <sub>16</sub> )...		00 <sub>16</sub>
(7) Port P7 directional register (D7)(D3 <sub>16</sub> )...		00 <sub>16</sub>
(8) Interrupt request distinguish register 1 (EB <sub>16</sub> )...		00 <sub>16</sub>
(9) Interrupt request distinguish register 2 (EA <sub>16</sub> )...		00 <sub>16</sub>
(10) PWM control register (F3 <sub>16</sub> )...		0 0 0 0 0 0 0 0
(11) Serial I/O mode register (SM)(F6 <sub>16</sub> )...		-- 0 0 0 0 0 0 0 0
(12) Timer 4, 5, 6 mode register (F8 <sub>16</sub> )...		00 <sub>16</sub>
(13) Interrupt control register (IM)(FE <sub>16</sub> )...		00 <sub>16</sub>
(14) Timer control register (TM)(FF <sub>16</sub> )...		00 <sub>16</sub>
(15) A-D control register (AC)(F2 <sub>16</sub> )...		00 <sub>16</sub>
(16) Processor status register		-- -- -- -- 1 -- --
(17) Program counter (PC <sub>H</sub> )...	Contents of address 3FFF <sub>16</sub>	
(PC <sub>L</sub> )...	Contents of address 3FFE <sub>16</sub>	

Note : Since the contents of both registers other than those listed above (including timers and the serial I/O register) and the RAM are undefined at reset, it is necessary to set initial values.

Fig. 17 Internal state of microcomputer at reset

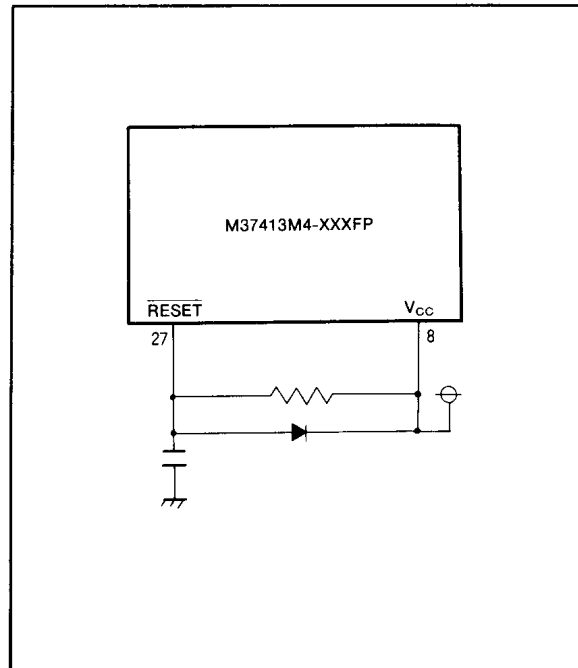

Fig. 18 Example of reset circuit

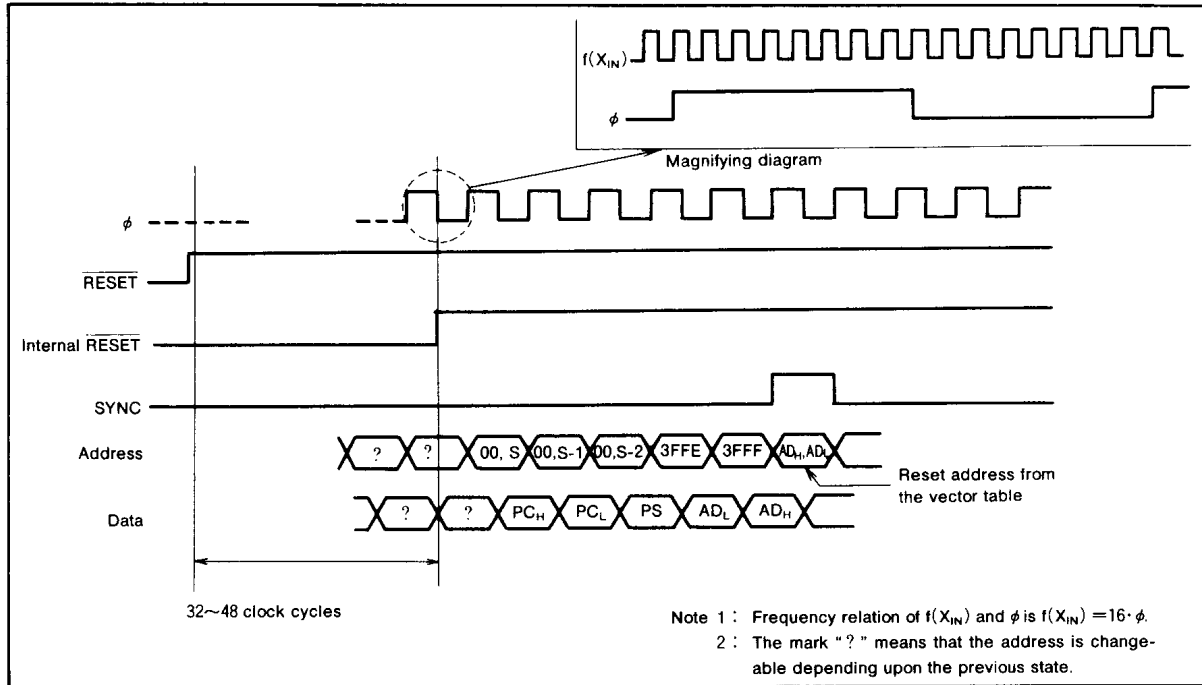

Fig. 19 Timing diagram at reset

SINGLE-CHIP 8-BIT CMOS MICROCOMPUTER

I/O PORTS

(1) Port P0

Port P0 is an 8-bit I/O port with CMOS outputs and pull-up transistor options available. As shown in Figure 1, P0 can be accessed as memory through zero page address 00E0<sub>16</sub>. Port P0's directional register allows each bit to be programmed individually as input or output. The directional register (zero page address 00E1<sub>16</sub>) can be programmed as input with "0", or as output with "1". When in the output mode, the data to be output is latched to the port register and output. When data is read from the output port, the output pin level is not read, only the latched data of the port register is read. Therefore, a previously output value can be read correctly even though the output voltage level has been shifted up or down. Port pins set as input are in the high impedance state so the signal level can be read. When data is written into the input port, the data is latched only to the output register and the pin still remains in the high impedance state.

(2) Port P1

Port P1 has the same function as P0 but the output structure is N-ch open drain.

(3) Port P2

Port P2 has the same function as P0. Following the execution of STP or WIT instruction, key matrix with port P2 can be used to generate the interrupt to bring the microcomputer back in its normal state. The pin to be used as the key on wake up must be with key on wake up option and its value in directional register must be "0".

(4) Port P3

Port P3 has the same functions P0 except that part of P3 is common with the serial I/O, output of timer4, clock oscillation of timer clock and interrupt input. The output is N-channel open drain. When P3<sub>0</sub> and P3<sub>1</sub> pins are used for X<sub>CIN</sub> input, pull-up is inhibited.

(5) Port P4

Port P4 is an 8-bit input port. P4<sub>0</sub>~P4<sub>3</sub> are in common with the IN<sub>4</sub>~IN<sub>7</sub>.

(6) Port P5

Port P5 has the same functions as P0 except that part of P5 is common with the counter input pin, SIG pin, and PWM output pin. The output is N-channel open drain output.

(7) Port P6

Port P6 has the same function as P0 but the output structure is N-ch open drain.

(8) Port P7

Port P7 has the same function as P0. Following the execution of STP or WIT instruction, key matrix with port P7 can be used to generate the interrupt to bring the microcomputer back in its normal state. The pin to be used as the key on wake up must be with key on wake

up option and its value in directional register must be "0".

(9) Analog input(IN<sub>0</sub>~IN<sub>7</sub>)

This is a port for an analog input of A-D converter. IN<sub>4</sub>~IN<sub>7</sub> are in common with the P4<sub>0</sub>~P4<sub>3</sub>.

(10) INT<sub>1</sub>

The INT<sub>1</sub> pin is an interrupt input pin. The INT<sub>1</sub> interrupt request bit (bit 7 of address 00FE<sub>16</sub>) is set to "1" when the input level of this pin changes from "H" to "L" (or "L" to "H"). This input level is read in the bit 7 of serial I/O mode register (address 00F6<sub>16</sub>).

(11) INT<sub>2</sub>(P3<sub>2</sub>/INT<sub>2</sub>)

The INT<sub>2</sub> pin is an interrupt input pin common with P3<sub>2</sub>. When P3<sub>2</sub>'s directional register is set for input ("0"), this pin can be used as an interrupt input. The INT<sub>2</sub> interrupt request bit (bit 3 of address 00EB<sub>16</sub>) is automatically set to "1" when the input level of this pin changes from "H" to "L" (or from "L" to "H").

(12) INT<sub>3</sub>(P5<sub>0</sub>/INT<sub>3</sub>)

The INT<sub>3</sub> pin is an interrupt input pin common with P5<sub>0</sub>. The other functions are the same as INT<sub>2</sub>.

SINGLE-CHIP 8-BIT CMOS MICROCOMPUTER

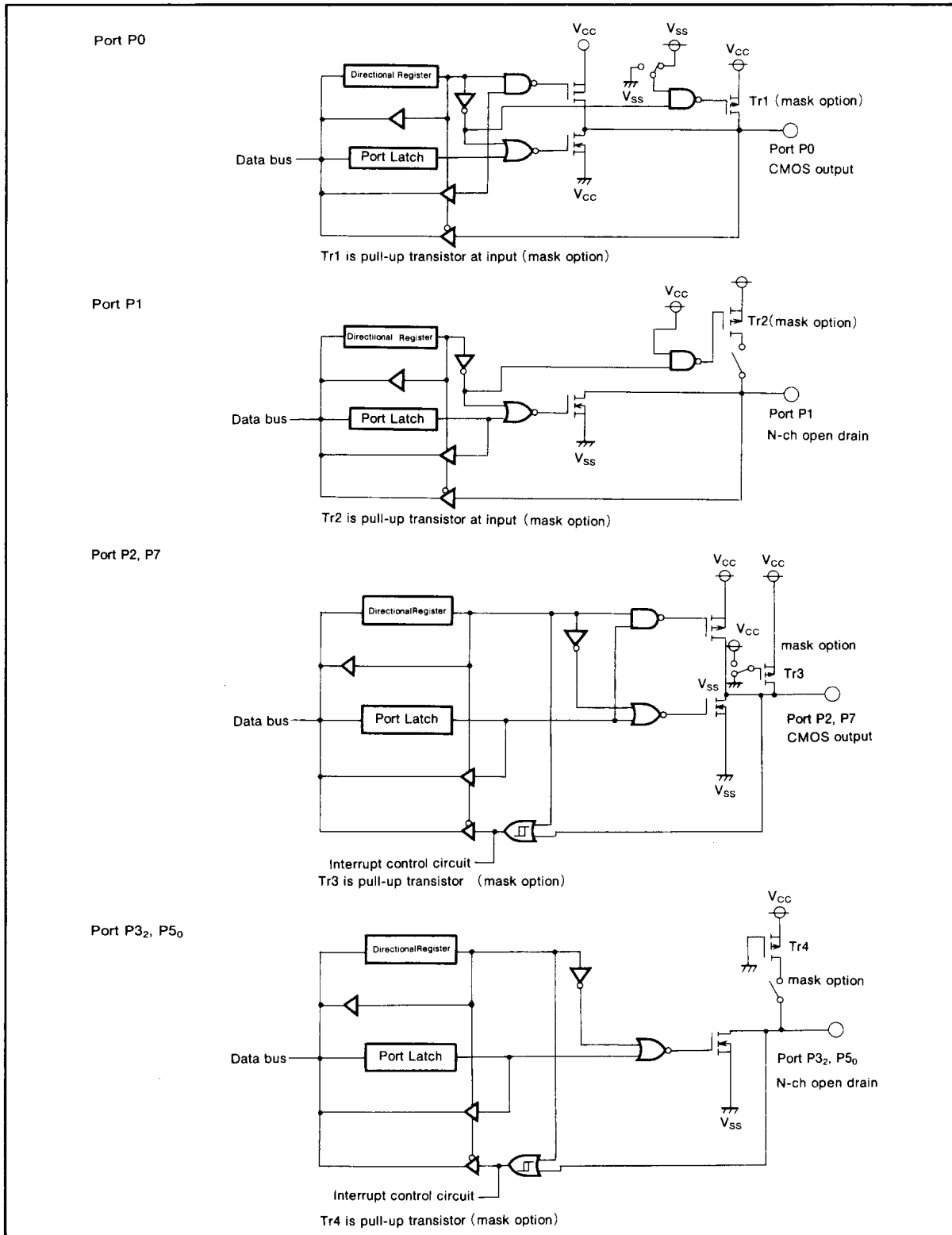

Fig. 20 Block diagram of ports P0~P2, P3<sub>2</sub>, P5<sub>0</sub> and P7

SINGLE-CHIP 8-BIT CMOS MICROCOMPUTER

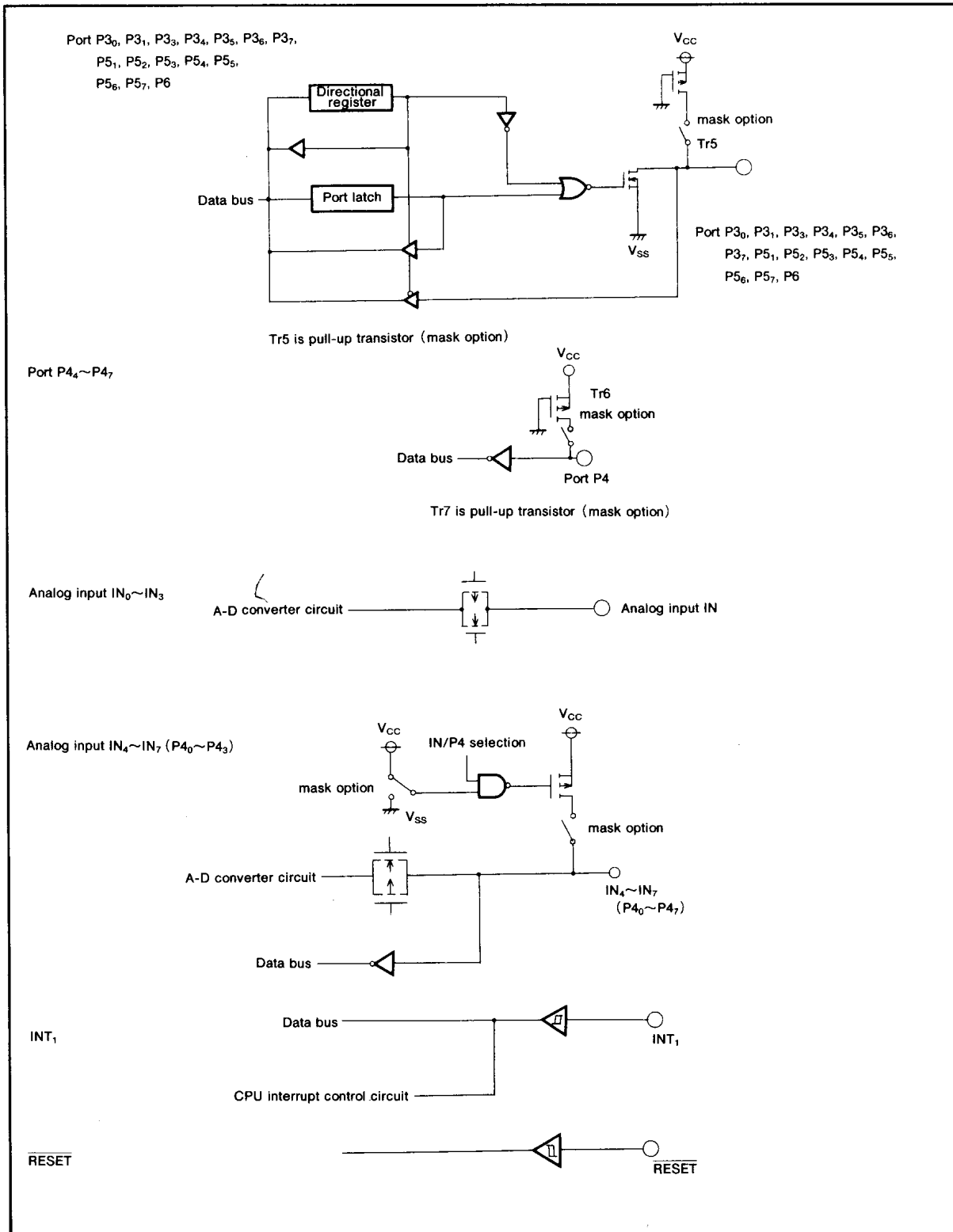

Fig. 21 Block diagram of ports P3, P4, P5<sub>1</sub>~P5<sub>7</sub>, P6, analog input port IN, INT<sub>1</sub>, RESET

**CLOCK GENERATING CIRCUIT**

The M37413M4-XXXFP has two internal clock generators. Figure 24 shows a block diagram of the clock generator. Normally, the frequency applied to the clock input pin  $X_{IN}$  divided by four is used as the internal clock (timing output)  $\phi$ . Serial I/O mode register bit 5 can be used to switch the internal clock  $\phi$  to 1/2 the frequency applied to the clock input pin  $X_{CIN}$ . In this case, the pull-up option to these pins are inhibited.

These signals can also be changed via bit5 ( $AC_5$ ) and bit6 ( $AC_6$ ) of the A-D control register. When  $AC_6$  and  $AC_5$  are [00], the internal clock is chosen  $X_{IN}/16$ . When they are [01], the internal clock is chosen  $X_{IN}/4$ . When they are [10] and [11], the internal clock is  $X_{CIN}/2$ . The one of clock  $X_{IN}$  and clock  $X_{CIN}$ , isn't in use for the internal clock (none system clock), stops when the bit6 ( $SM_6$ ) of serial I/O mode register is "0". In order to restart the clock as the internal clock,  $SM_6$  is set to "1" and wait until the oscillation becomes stability by the software then the internal clock is chosen  $AC_6$  and  $AC_5$ .

Figure 22 shows a circuit exmple using a ceramic (or crystal) oscillator. Use the manufacturer's recommended values for constants such as capacitance which is unique for each oscillator. when using an external clock signal, input from the  $X_{IN}$ ( $X_{CIN}$ ) pin and leave the  $X_{OUT}$ ( $X_{COUT}$ ) pin open. A circuit example is shown in Figure 23.

The M37413M4-XXXFP has two low power consumption modes, stop and wait. The microcomputer enters a stop mode when the STP instruction is executed. The oscillator (both  $X_{IN}$  clock and  $X_{CIN}$  clock) stops with the internal clock  $\phi$  held at "H" level. In this case timer 1 and timer 2 are forcibly connected and  $\phi/4$  is selected as timer 1 input. When restarting oscillation, set the suitable value for timer 1 and timer 2 in order to enable the oscillator to stabilize. Before executing the STP instruction, the timer 1 count stop bit must be set to supply ("0"), timer 2 interrupt enable bit ( $IF1_4$ ) of interrupt request distinguish register 1 must be set to enable ("1"), timer 2 interrupt request bit ( $IF1_5$ ) of interrupt request distinguish register must be set to disable ("0"). And serial I/O or timer 2 interrupt enable bit ( $TM_6$ ) and serial I/O or timer 2 interrupt request bit ( $TM_7$ ) of timer control register must be set to disable ("0").

Oscillation is restarted (reset stop mode) when  $INT_1$ ,  $INT_2$ , or  $INT_3$  interrupt is received. The interrupt enable bit of the interrupt used to reset the stop mode must be set to "1". When restarting oscillation with an interrupt, the internal clock  $\phi$  is held "H" until timer 2 overflows and is not supplied to the CPU. When oscillation is restarted by reset, "L" level must be applied to the RESET pin until the oscillation stabilizes because no wait time is generated.

The microcomputer enters a wait mode when WIT instruction is executed. The internal clock  $\phi$  stops at "H" level, but the oscillator does not stop.  $\phi$  is re-supplied (wait mode reset) when the processor is reset or when it receives an

interrupt. Instructions can be executed immediately because the oscillator is not stopped. The interrupt enable bit of the interrupt used to reset the wait mode must be set to "1" before executing the WIT instruction.

When the interrupt is accepted and after the interrupt subroutine is executed, the next instruction to STP or WIT is executed. It is possible to cancel stop and wait mode by reset. In this case, the execution is started from the address is set to reset vector.

Transition of states for the system clock is shown in Figure 25. The change order of the internal clock is shown in Figure 25.

When STP instruction is executed from the states of A, B, C, D and E, it will be the same state as H (stop state). If the interrupt is executed in stop state, it will return the state before STP instruction is executed.

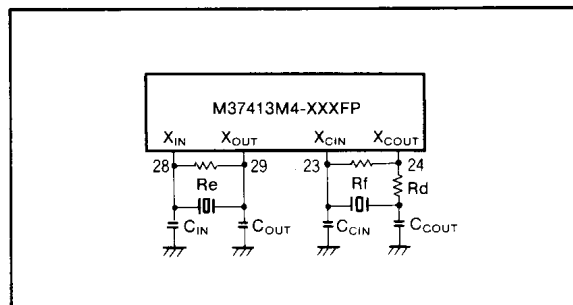

Fig. 22 External ceramic resonator circuit

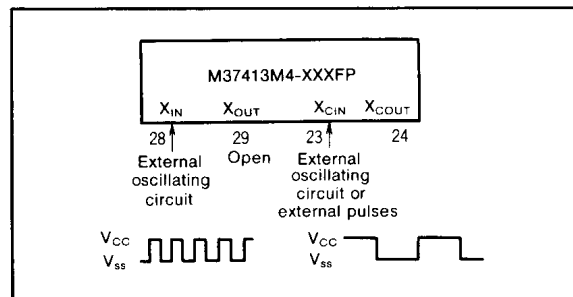

Fig. 23 External clock input circuit



**SINGLE-CHIP 8-BIT CMOS MICROCOMPUTER**

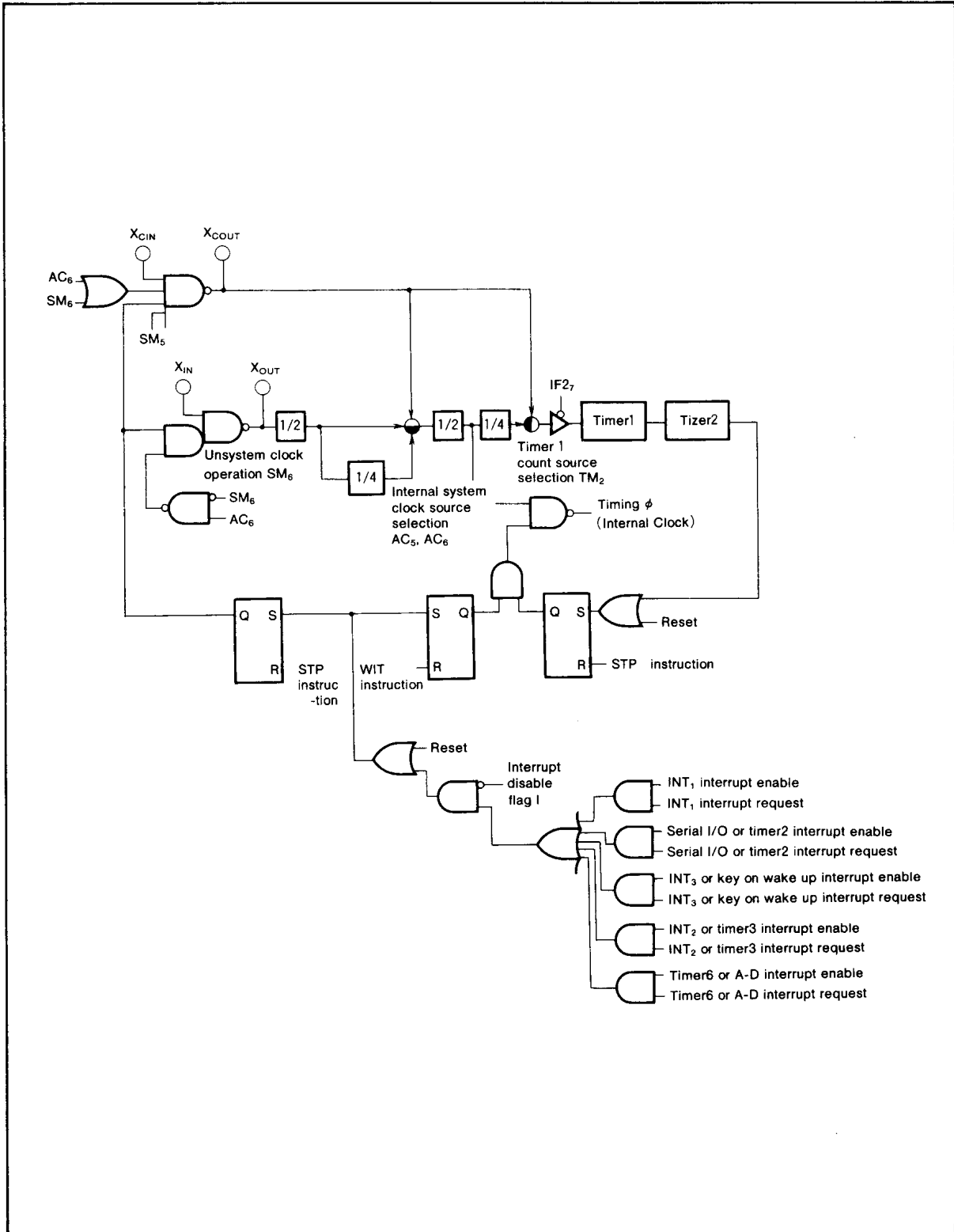
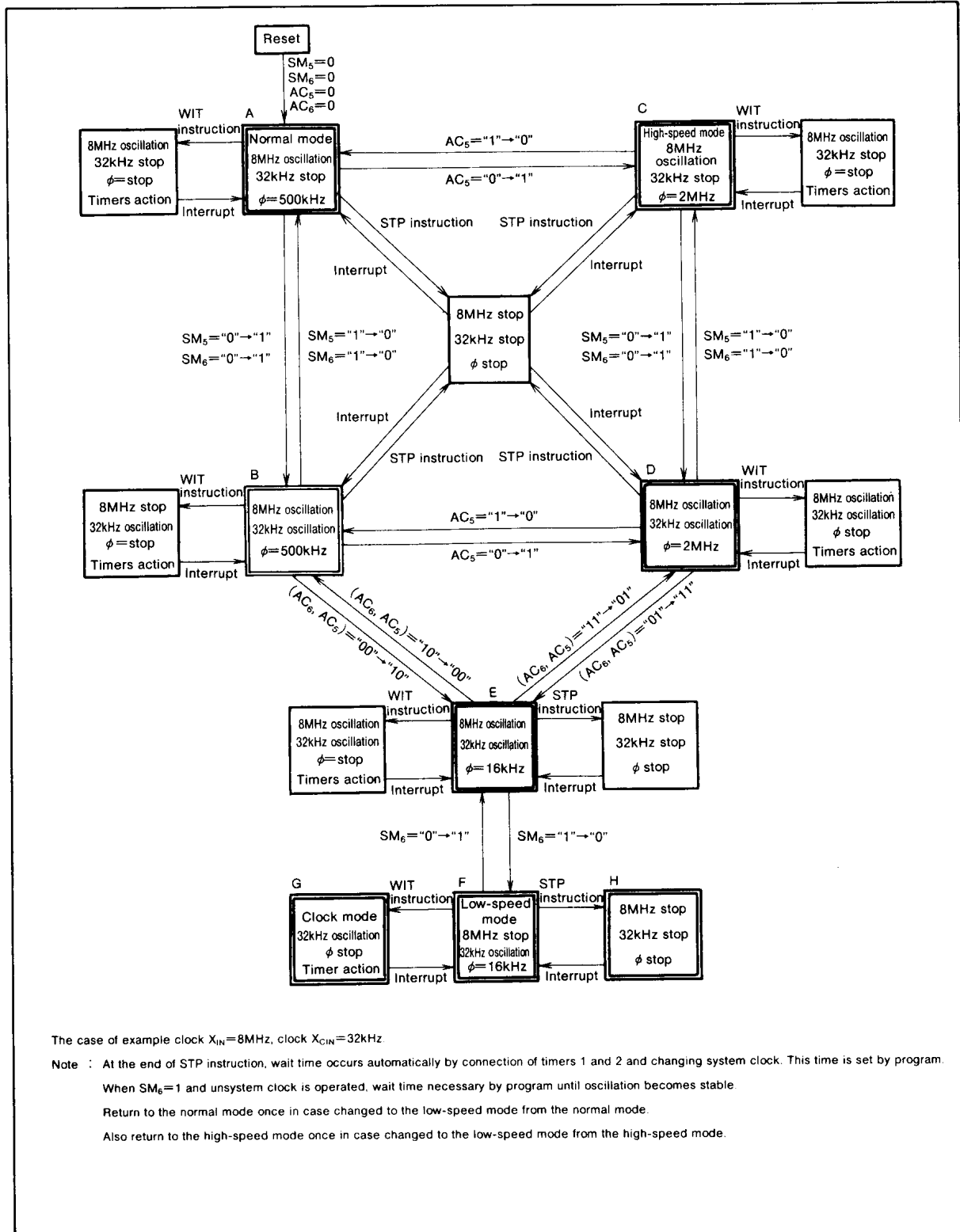

Fig. 24 Block diagram of clock generating circuit

SINGLE-CHIP 8-BIT CMOS MICROCOMPUTER



The case of example clock  $X_{IN}=8MHz$ , clock  $X_{CIN}=32kHz$ .

Note : At the end of STP instruction, wait time occurs automatically by connection of timers 1 and 2 and changing system clock. This time is set by program.

When  $SM_6=1$  and unsystem clock is operated, wait time necessary by program until oscillation becomes stable

Return to the normal mode once in case changed to the low-speed mode from the normal mode.

Also return to the high-speed mode once in case changed to the low-speed mode from the high-speed mode.

Fig. 25 Transition of states for the system clock

SINGLE-CHIP 8-BIT CMOS MICROCOMPUTER

**PROGRAMMING NOTES**

- (1) The frequency ratio of the timer is  $1/(n+1)$ .
- (2) The count value of timers 1, 2, 3, 4 can be read at an arbitrary timing when the timing  $\phi$  divided by 4 or timer overflow is input to these timers. If  $X_{CIN}$  or  $CNT_1$  input is input to these timers, the value of timer 1, 2, 3, 4 must be read only when the input of timers is not changing or the timer count is stopped.  
Also the count value of timers 5, 6 which are used in the event counter mode must be read when the external input is at the "L" level. When timers 5, 6 are used in the timer mode, the count value of these timers cannot be read.
- (3) Even though the BBC and BBS instructions are executed after the interrupt request bits are modified (by the program), those instructions are only valid for the contents before the modification. Also, at least one instruction cycle must be used (such as a NOP) between the modification of the interrupt request bits and the execution of the BBC and BBS instructions.
- (4) ① After the ADC and SBC instructions are executed (in decimal mode), one instruction cycle (such as a NOP) is needed before the SEC, CLC, or CLD instructions are executed.  
② In decimal mode, the negative (N), overflow (V) and zero (Z) flags are invalidated.
- (5) A NOP instruction must be used after the execution of a PLP instruction.
- (6) ① The timer 1 and timer 2 must be set the necessary value immediately before the execution of a STP instruction.  
Also the following conditions must be satisfied:
  - Timer 1 count stop bit is set to "0"
  - Timer 2 interrupt enable bit is set to "1"
  - Timer 2 interrupt request bit is set to "0"
  - Serial I/O or timer 2 interrupt enable bit is set to "0"
  - Serial I/O or timer 2 interrupt request bit is set to "0"② To restart oscillation when it is stopped by STP instruction or unsystem clock operation bit, wait for a specified time which is needed for the oscillator to stabilize.
- (7) Some instructions can be used to write contents of the timer control register, the interrupt control register and interrupt request distinguish register 1, 2. If the SEB or CLB instruction or a set of instruction that acts as the SEB or CLB instruction (for instance, LDA TC+SEB 7, A+STA TC) is used, an interrupt request which is input during execution of these instructions may be cleared. Therefore, these instructions should be used only when there is no problem even if such an interrupt request is cleared. Usually, the LDM or STA instruction is used. Use the LDA instruction (IMM, T=1) to write to interrupt cause recognition register 2 only when A-D interrupt or timer 6 interrupt is used.

- (8) When LCD trun-on bit (bit 3 of address 00F5<sub>16</sub>) of the LCD mode register is "1", don't stop the timers or count source for timers.
- (9) After switching the serial I/O transfer clock, initialize the serial I/O counter (write to address 00F7<sub>16</sub>).
- (10) To use an external clock as the serial I/O transfer clock, initialize the serial I/O counter when the external clock is "H" level.
- (11) To use the P3<sub>0</sub> and P3<sub>1</sub> pins as the I/O pins of the clock for clock function, do not use the pull-up resistors by option.

**DATA REQUIRED FOR MASK ORDERING**

Please send the following data for mask orders.

- (1) mask ROM confirmation form
  - (2) mark specification form
  - (3) ROM data ..... EPROM 3sets
- Write the following option on the mask ROM confirmation form
- Port P0 pull-up transistor bit
  - Port P1 pull-up transistor bit
  - Port P2 pull-up transistor bit
  - Port P3 pull-up transistor bit
  - Port P4 pull-up transistor bit
  - Port P5 pull-up transistor bit
  - Port P6 pull-up transistor bit
  - Port P7 pull-up transistor bit
  - Port P2 key on wake up
  - Port P7 key on wake up

**MITSUBISHI MICROCOMPUTERS**  
**M37413M4-XXXFP**

**SINGLE-CHIP 8-BIT CMOS MICROCOMPUTER**

**ABSOLUTE MAXIMUM RATINGS**

Symbol	Parameter	Conditions	Ratings	Unit
$V_{CC}$	Supply voltage		-0.3~7	V
$AV_{CC}$	Analog supply voltage	$V_{CC}=AV_{CC}$	-0.3~7	V
$V_I$	Input voltage P0~P07, P20~P27, P30, P31, P40~P43, P70~P77, IN0~IN7, VREF, XIN		-0.3~ $V_{CC}+0.3$	V
$V_I$	Input voltage CNVSS		-0.3~7	V
$V_I$	Input voltage INT1, RESET, P10~P17, P32~P37, P50~P57, P60~P67		-0.3~10	V
$V_O$	Output voltage P00~P07, P20~P27, P30, P31, P70~P77, XOUT		-0.3~ $V_{CC}+0.3$	V
$V_O$	Output voltage P10~P17, P32~P37, P50~P57, P60~P67		-0.3~10	V
$P_d$	Power dissipation	$T_a = 25^\circ\text{C}$	300	mW
$T_{opr}$	Operating temperature		-20~75	$^\circ\text{C}$
$T_{stg}$	Storage temperature		-40~125	$^\circ\text{C}$

**RECOMMENDED OPERATING CONDITIONS** ( $V_{CC}=2.5\sim 5.5\text{V}$ ,  $V_{SS}=0\text{V}$ ,  $T_a=-20\sim 75^\circ\text{C}$ , unless otherwise noted)

Symbol	Parameter	Conditions	Limits			Unit
			Min.	Typ.	Max.	
$V_{CC}$	Supply voltage (Note 1)	$f(X_{IN}) = 8\text{ MHz High-speed mode}$	4.5		5.5	V
		$f(X_{IN}) = 8\text{ MHz Normal mode or}$	2.5		5.5	
		$f(X_{IN}) = 2\text{ MHz High-speed mode (Note 2)}$				
$V_{SS}$	Supply voltage			0		V
$V_{IH}$	"H" input voltage P00~P07, P30, P31, P40~P47, CNVSS (Note 3)		0.7 $V_{CC}$		$V_{CC}$	V
$V_{IH}$	"H" input voltage P20~P27		0.8 $V_{CC}$		$V_{CC}$	V
$V_{IH}$	"H" input voltage P10~P17, P51~P57, P60~P67, SIN		0.7 $V_{CC}$		10	V
$V_{IH}$	"H" input voltage P32~P37, P50, INT1, INT2, INT3, CNT1, CNT2, SIG, CLK		0.8 $V_{CC}$		10	V
$V_{IH}$	"H" input voltage RESET, XIN, XCIN		0.85 $V_{CC}$		10	V
$V_{IL}$	"L" input voltage P00~P07, P10~P17, P30, P31, P40~P43, P51~P57, P60~P67, SIN		0		0.25 $V_{CC}$	V
$V_{IL}$	"L" input voltage P20~P27, P32~P37, P50, INT1, INT2, INT3, CNT1, CNT2, SIG, CLK		0		0.2 $V_{CC}$	V
$V_{IL}$	"L" input voltage RESET, XIN, XCIN		0		0.15 $V_{CC}$	V
$I_{OH}$	"H" output current P00~P07, P20~P27, P70~P77, XOUT (Note 4)				-1	mA
$I_{OL}$	"L" output current P00~P07, P20~P27, P30~P37, P50~P57, P60~P67, P70~P77, XOUT (Note 5)				1	mA
$I_{OL}$	"L" output current P10~P17 (Note 6)	$V_{CC}=3\text{V}$			10	mA
		$V_{CC}=5\text{V}$			20	
$f(X_{IN})$	Clock oscillating frequency		0.2		8.2	MHz
$f(X_{CIN})$	Clock oscillating frequency for clock function		30		50	kHz

- Note 1 : When only maintaining the RAM data, minimum value of  $V_{CC}$  is 2 V.  
 2 : We say the high-speed mode, when the system clock is chosen  $X_{IN}/4$ , and the low-speed mode, when the system clock is chosen  $X_{IN}/16$ .  
 3 : When P31 is used as  $X_{CIN}$ ,  $V_{IH}$  and  $V_{IL}$  of P31 is  $0.85V_{CC} \leq V_{IH} \leq V_{CC}$  and  $0 \leq V_{IL} \leq 0.15V_{CC}$ .  
 4 : The total  $I_{OH(peak)}$  of port P0, P2, P7 and  $X_{OUT}$  is less than 35mA.  
 5 : The total  $I_{OH(peak)}$  of port P0, P2, P3, P5, P6 and P7 is less than 32mA.  
 6 : The total peak current of  $I_{OL}$  of port P1 is less than 80mA and the average current of total  $I_{OL}$  of port P1 is less than 40mA.

**MITSUBISHI MICROCOMPUTERS**  
**M37413M4-XXXFP**

**SINGLE-CHIP 8-BIT CMOS MICROCOMPUTER**

**ELECTRICAL CHARACTERISTICS** ( $V_{SS}=0V$ ,  $T_a=-20\sim 75^\circ C$ , unless otherwise noted)

Symbol	Parameter	Test conditions	Limits			Unit		
			Min.	Typ.	Max.			
$V_{OH}$	"H" output voltage $P0_0\sim P0_7, P2_0\sim P2_7, P7_0\sim P7_7$	$V_{CC}=5V, I_{OH}=-0.5mA$	4			V		
		$V_{CC}=3V, I_{OH}=-0.3mA$	2.4					
$V_{OH}$	"H" output voltage $X_{OUT}$	$V_{CC}=5V, I_{OH}=-0.3mA$ $V_{CC}=3V, I_{OH}=-0.1mA$	4 2.4			V		
$V_{OL}$	"L" output voltage $P0_0\sim P0_7, P2_0\sim P2_7, P3_0\sim P3_7, P5_0\sim P5_7, P6_0\sim P6_7, P7_0\sim P7_7, T, S_{OUT}, CLK, S_{RDY}, SIG, PWM0\sim PWM3$	$V_{CC}=5V, I_{OL}=1mA$			1	V		
		$V_{CC}=3V, I_{OL}=0.5mA$			0.6			
$V_{OL}$	"L" output voltage $P1_0\sim P1_7$	$V_{CC}=5V, I_{OL}=20mA$ $V_{CC}=3V, I_{OL}=10mA$			2 1.5	V		
$V_{OL}$	"L" output voltage $X_{OUT}$	$V_{CC}=5V, I_{OL}=0.3mA$			1	V		
		$V_{CC}=3V, I_{OL}=0.1mA$			0.6			
$V_{T+}-V_{T-}$	Hysteresis $INT_1, INT_2, INT_3, CLK, CNT_1, CNT_2, SIG, S_{IN}, P2_0\sim P2_7, P7_0\sim P7_7, X_{CIN}$	$V_{CC}=5V$		0.7		V		
		$V_{CC}=3V$		0.5				
$V_{T+}-V_{T-}$	Hysteresis $\overline{RESET}$	$V_{CC}=5V$ $V_{CC}=3V$		2 1.2		V		
$V_{T+}-V_{T-}$	Hysteresis $X_{IN}$	$V_{CC}=5V$		0.5		V		
		$V_{CC}=3V$		0.35				
$I_{IL}$	"L" input current $ P0_0\sim P0_7, P1_0\sim P1_7, P2_0\sim P2_7, P3_0\sim P3_7, P4_0\sim P4_7, P5_0\sim P5_7, P6_0\sim P6_7, P7_0\sim P7_7 $ without pull-up $T_r$ , (Note 1), $INT_1, \overline{RESET}, X_{IN}$	$V_{CC}=5V, V_i=0V$			-5	$\mu A$		
		$V_{CC}=3V, V_i=0V$			-3			
$I_{IH}$	"H" input current $P0_0\sim P0_7, P2_0\sim P2_7, P3_0, P3_1, P4_0\sim P4_7, P7_0\sim P7_7, X_{IN}, X_{CIN}, CNV_{SS}$	$V_{CC}=5V, V_i=5V$			5	$\mu A$		
		$V_{CC}=3V, V_i=3V$			3			
$I_{IH}$	"H" input current $ P1_0\sim P1_7, P3_0\sim P3_7, P5_0\sim P5_7, P6_0\sim P6_7 $ without pull-up $T_r, INT_1, \overline{RESET}$	$V_i=10V$			10	$\mu A$		
$R_{PL}$	Pull-up $T_r, P0_0\sim P0_7, P1_0\sim P1_7, P2_0\sim P2_7, P3_0\sim P3_7, P4_0\sim P4_3, P5_0\sim P5_7$	$V_{CC}=5V, V_i=0V$	7	15	30	k $\Omega$		
		$V_{CC}=3V, V_i=0V$	10	30	60			
$I_{CC}$	Supply current	at operation	$f(X_{IN})=8MHz$ High-speed mode $V_{CC}=5V$		6	12	mA	
			$f(X_{IN})=8MHz$ Normal mode $V_{CC}=3V$		1	4		
			$f(X_{CIN})=32kHz, V_{CC}=3V$		18	36		
		at wait mode	$f(X_{IN})=8MHz, V_{CC}=3V$				3	mA
			$f(X_{CIN})=32kHz, V_{CC}=3V$				4	
			$T_a=25^\circ C$		0.1	1.0	$\mu A$	
$T_a=75^\circ C$			6.0					
$V_{RAM}$	RAM retention voltage		2		5.5	V		

Note : Also the same when each port is used as  $INT_2, INT_3, CNT_1, CNT_2, SIG, S_{IN}$  and  $X_{CIN}$ , respectively.

SINGLE-CHIP 8-BIT CMOS MICROCOMPUTER

**A-D CONVERTER CHARACTERISTICS** ( $V_{CC}=5V$ ,  $V_{SS}=AV_{SS}=0V$ ,  $T_a=25^\circ C$ ,  $f(X_{IN})=8MHz$ , unless otherwise noted)

Symbol	Parameter	Test conditions	Limits			Unit
			Min.	Typ.	Max.	
—	Resolution				8	bits
—	Non-linearity error	$V_{CC}=V_{REF}=5.12V$			$\pm 2$	LSB
		$V_{CC}=V_{REF}=3.072V$			$\pm 2$	
—	Differential non-linearity	$V_{CC}=V_{REF}=5.12V$			$\pm 0.9$	LSB
		$V_{CC}=V_{REF}=3.072V$			$\pm 0.9$	
$V_{OT}$	Zero transition error	$V_{CC}=V_{REF}=5.12V$			2	LSB
		$V_{CC}=V_{REF}=3.072V$			2	
$V_{FST}$	Full-scale transition error	$V_{CC}=V_{REF}=5.12V$			6	LSB
		$V_{CC}=V_{REF}=3.072V$			10	
$T_C$	Conversion time	$V_{CC}=2.5\sim 5.5V$ High-speed mode		$200/f(X_{IN})$		$\mu s$
		$V_{CC}=2.5\sim 5.5V$ Normal mode		$800/f(X_{IN})$		
$I_{REF}$	Reference input current	$V_{REF}=5V$		1.0	2.5	mA
		$V_{REF}=3V$		0.5	1.5	
$I_{IN}$	Analog port input current	$V_{IN}=0\sim V_{CC}$		1	10	$\mu A$
$V_{IN}$	Analog input voltage	$V_{CC}=2.5\sim 5.5V$	$AV_{SS}$		$V_{CC}$	V
$V_{REF}$	Reference input voltage		2.5		$V_{CC}$	V