

SWITCHING CHARACTERISTIC

	PARAMETER	INPUT	OUTPUT	TEST CONDITIONS†	+25°C			
					MIN	TYP	MAX	UNIT
t+ t-+	Propagation Delay	$\bar{B}1$	$\bar{P}G$	$\bar{S}1$ Low	—	4	—	ns
t+					—	4	—	—
t-					—	2.0	—	—
t+ t-	Propagation Delay	$B1$	$\bar{G}G$	$\bar{S}2$ Low	—	5.2	—	ns
t+					—	5.7	—	—
t-					—	2.0	—	—
t+ t-	Propagation Delay	$\bar{B}1$	\bar{C}_{n+4}	$\bar{S}0$ or $\bar{S}1$ or $\bar{S}2$ or $\bar{S}3$ Low	—	5.9	—	ns
t+					—	5.6	—	—
t-					—	2.0	—	—
t+ t-	Rise Time				—	2.0	—	—
t+					—	2.0	—	—
t-					—	2.0	—	—

+High = +1.11V
 Low = +0.31V
 $V_{CC1} = V_{CC2} = +2.0$ Vdc, $V_{EE} = -3.2$ Vdc

SWITCHING TIME TEST CIRCUIT

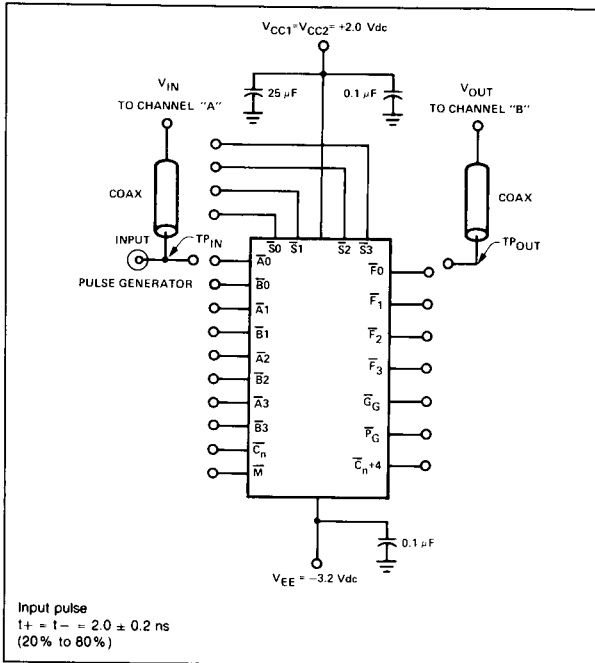

Each ECL 10,000 series has been designed to meet the dc specifications shown in the test table, after thermal equilibrium has been established. The circuit is in a test socket or mounted on a printed circuit board and transverse air flow greater than 500 linear fpm is maintained. Outputs are terminated through a 50-ohm resistor to -2.0 volts.

PROPAGATION DELAY WAVEFORMS @ 25°C

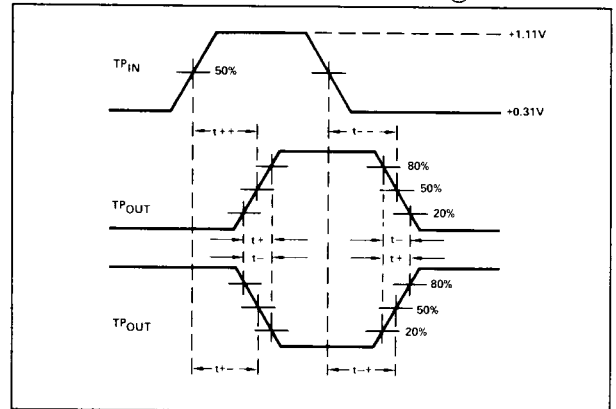

All input and output cables to the scope are equal lengths of 50-ohm coaxial cable. Wire length should be $\lt; 1/4$ inch from TP_{in} to input pin and TP_{out} to output pin.

DESCRIPTION

The 10190 is both a general purpose ECL 10,000 series line receiver and an MST (IBM 370) to ECL translator. With the V_{CC} Terminal (Pin 9) connected to ground, the device will accept either single-ended or differential ECL 10K signals. With V_{CC} connected to +1.25 Volts, the device will accept MST logic levels (+0.4 and -0.4 nominal). In either case, the output of the 10190 is standard ECL 10K.

When used in the translator mode, one of the differential inputs is tied to ground and the other to the MST source. V_{CC} is non-critical between +0.5 and +2.0 Volts.

In the ECL line receiver mode, a single ended input is accommodated by connecting the other input to an external V_{BB} source.

FEATURES

- High speed; propagation delay = 2.5 ns TYP
- High common mode noise rejection
- Output drives 50 Ω lines
- Dual-purpose
 - Quad line receiver (ECL-ECL)
 - Transistor (MST-ECL)
- High input impedance
- Non-critical V_{CC} tolerance in translator mode (0.5 to +2.0 Volts)
- Open emitter outputs
- Immune to power supply faults
- Defined output (low) with both inputs open

APPLICATIONS

- Line receiver
- MST to ECL translator

PROPAGATION DELAY WAVEFORMS @ 25°C

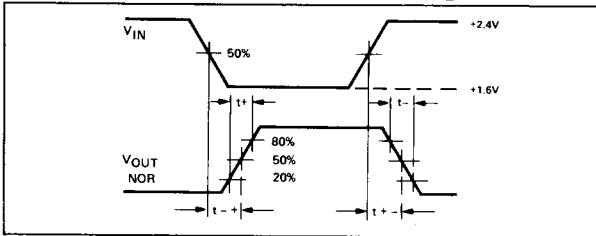

NOTES:

1. Each ECL 10,000 series device has been designed to meet the DC specifications shown in the test table, after thermal equilibrium has been established. The circuit is in a test socket or mounted on a printed circuit board and transverse air flow greater than 500 linear fpm is maintained. Voltage levels will shift approximately 3 mV with an air flow of 200 linear fpm. Outputs are terminated through a 50-ohm resistor to 2.0V.
2. For AC tests, all input and output cables to the scope are equal lengths of 50-ohm coaxial cable. Wire length should be < 1/4 inch from TP_{in} to input pin and TP_{out} to output pin. A 50-ohm termination to ground is located in each scope input. Unused outputs are connected to a 50-ohm resistor to ground.
3. Test procedures are shown for only one input or set of input conditions. Other inputs are tested in the same manner.
4. All voltage measurements are referenced to the ground terminal. Terminals not specifically referenced are left electrically open.

LOGIC DIAGRAM

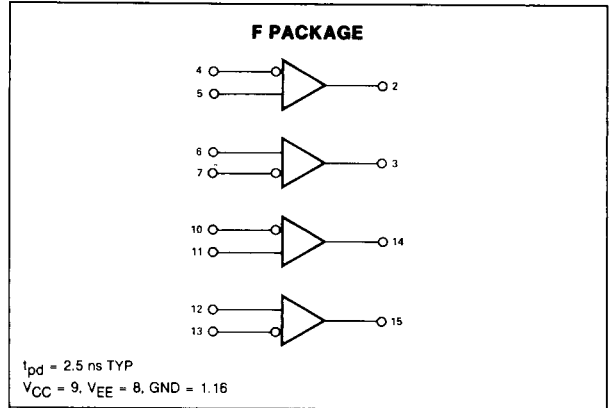

SWITCHING TIME TEST CIRCUIT

