

THOMSON SEMICONDUCTORS

UA776

PROGRAMMABLE SINGLE OP-AMPS

The UA776 programmable operational amplifier is characterized by high input impedance, low supply currents and low input noise over a wide range of operating supply voltages.

Coupled with programmable electrical characteristics it is an extremely versatile amplifier for use in high accuracy, low power consumption analog applications.

Input noise voltage and current, power consumption, and input current can be optimized by a single resistor or current source that sets the chip quiescent current for nano-watt power consumption or for characteristics similar to the UA741.

Internal frequency compensation, absence of latch up, high slew rate and short-circuit protection assure ease of use in long time integrators, active filters, and sample and hold circuits.

- Micropower operation.
- No frequency compensation required.
- Wide programming range.
- High slew rate.
- Short-circuit protection.

ORDERING INFORMATION

Hi-Rel versions available - See chapter 14

PART NUMBER	TEMPERATURE RANGE	PACKAGE			
		H	DP	GC	FP
UA776C	0°C to + 70°C	•	•		•
UA776M	-55°C to +125°C	•		•	

Examples : UA776CH, UA776CDP, UA776CFP

PROGRAMMABLE SINGLE OP-AMPS

CASES

CB-11
(TO-99)

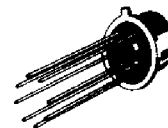

H SUFFIX
METAL CAN

CB-98



DP SUFFIX
PLASTIC PACKAGE

CB-705



GC SUFFIX
TRICECOP (LCC)

CB-342



FP SUFFIX
PLASTIC
MICROPACKAGE

PIN ASSIGNMENTS

(Top views)

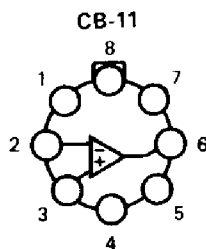

- 1 - Offset null
- 2 - Inverting input
- 3 - Non-inverting input
- 4 - V_{CC}^-
- 5 - Offset null
- 6 - Output
- 7 - V_{CC}^+
- 8 - I_{set}

CB-98
CB-342

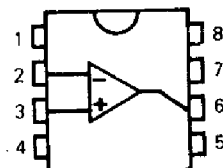

CB-705

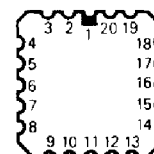

- 1 - NC
- 2 - Offset null
- 3 - NC
- 4 - NC
- 5 - Inverting input
- 6 - NC
- 7 - Non-inverting input
- 8 - NC
- 9 - NC
- 10 - V_{CC}^-
- 11 - NC
- 12 - Offset null
- 13 - NC
- 14 - NC
- 15 - Output
- 16 - NC
- 17 - V_{CC}^+
- 18 - NC
- 19 - NC
- 20 - I_{set}

THOMSON SEMICONDUCTORS

Sales headquarters
45, av. de l'Europe - 78140 VELIZY - FRANCE
Tel. : (3) 946 97 19 / Telex : 204780 F

ELECTRICAL CHARACTERISTICS

UA776M : $-55^{\circ}\text{C} \leq T_{\text{amb}} \leq +125^{\circ}\text{C}$, $V_{\text{CC}} = \pm 15\text{ V}$

UA776C : $-0^{\circ}\text{C} \leq T_{\text{amb}} \leq +70^{\circ}\text{C}$, $V_{\text{CC}} = \pm 15\text{ V}$

(Unless otherwise specified)

Characteristic	Symbol	$I_{\text{set}} = 1.5\ \mu\text{A}$			$I_{\text{set}} = 15\ \mu\text{A}$			Unit
		Min	Typ	Max	Min	Typ	Max	
Input offset voltage $T_{\text{amb}} = +25^{\circ}\text{C}$ $T_{\text{min}} \leq T_{\text{amb}} \leq T_{\text{max}}$	V_{IO} UA776M UA776C UA776M UA776C	— — — —	2 2 — —	5 6 6 7.5	— — — —	2 2 — —	5 6 6 7.5	mV
Input offset current $T_{\text{amb}} = +25^{\circ}\text{C}$ $T_{\text{amb}} = T_{\text{max}}$ $T_{\text{amb}} = T_{\text{min}}$	I_{IO} UA776M UA776C UA776M UA776C	— — — —	0.7 0.7 — —	3 6 5 6 10	— — — — —	2 2 — — —	15 25 15 25 40	nA
Input bias current $T_{\text{amb}} = +25^{\circ}\text{C}$ $T_{\text{amb}} = T_{\text{max}}$ $T_{\text{amb}} = T_{\text{min}}$	I_{IB} UA776M UA776C UA776M UA776C UA776M UA776C	— — — — — —	2 2 — — — —	7.5 10 7.5 10 20 20	— — — — — —	15 15 — — — —	50 50 50 50 120 100	nA
Large signal voltage gain ($V_{\text{O}} = \pm 10\text{ V}$) $T_{\text{amb}} = +25^{\circ}\text{C}$, $R_{\text{L}} \geq 5\text{ k}\Omega$ $T_{\text{amb}} = +25^{\circ}\text{C}$, $R_{\text{L}} \geq 75\text{ k}\Omega$ $T_{\text{min}} \leq T_{\text{amb}} \leq T_{\text{max}}$, $R_{\text{L}} \geq 75\text{ k}\Omega$	A_{VD} UA776M UA776C UA776M UA776C UA776M UA776C	— — 2.10 ⁵ 5.10 ⁴ 10 ⁵ 5.10 ⁴	— — 4.10 ⁵ 4.10 ⁵ — —	— — — — — —	10 ⁵ 5.10 ⁴ — — 7.5.10 ⁴ 5.10 ⁴	4.10 ⁵ 4.10 ⁵ — — — —	— — — — — —	V/V
Supply voltage rejection ratio ($R_{\text{S}} \leq 10\text{ k}\Omega$)	SVR UA776M UA776C	— —	25 25	150 200	— —	25 25	150 200	$\mu\text{V/V}$
Supply current $T_{\text{amb}} = +25^{\circ}\text{C}$ $T_{\text{min}} \leq T_{\text{amb}} \leq T_{\text{max}}$	I_{CC} UA776M UA776C UA776M UA776C	— — — —	20 20 — —	25 30 30 35	— — — —	160 160 — —	180 190 200 200	μA
Power consumption $T_{\text{amb}} = +25^{\circ}\text{C}$ $T_{\text{min}} \leq T_{\text{amb}} \leq T_{\text{max}}$	P_{D} UA776M UA776C UA776M UA776C	— — — —	— — — —	0.75 0.9 30 35	— — — —	— — — —	5.4 5.7 200 200	mW
Input voltage range	V_{I}	± 10	—	—	± 10	—	—	V
Common-mode rejection ratio ($R_{\text{S}} \leq 10\text{ k}\Omega$)	CMR	70	90	—	70	90	—	dB
Output short-circuit current	I_{OS}	—	3	—	—	12	—	mA
Output voltage swing $T_{\text{amb}} = +25^{\circ}\text{C}$, $R_{\text{L}} \geq 5\text{ k}\Omega$ $R_{\text{L}} \geq 75\text{ k}\Omega$ $T_{\text{min}} \leq T_{\text{amb}} \leq T_{\text{max}}$, $R_{\text{L}} \geq 75\text{ k}\Omega$	V_{OPP}	— ± 12 ± 10	— ± 14 —	— — —	± 10 — ± 10	± 13 — —	— — —	V
Offset voltage adjustment range ($T_{\text{amb}} = +25^{\circ}\text{C}$)	V_{IOR}	—	9	—	—	18	—	mV
Slew rate ($R_{\text{L}} \geq 5\text{ k}\Omega$, $T_{\text{amb}} = +25^{\circ}\text{C}$)	SV_{O}	—	0.1	—	—	0.8	—	V/ μs
Rise time ($V_{\text{I}} = +20\text{ mV}$, $C_{\text{L}} = 100\text{ pF}$, $R_{\text{L}} \geq 5\text{ k}\Omega$, $T_{\text{amb}} = +25^{\circ}\text{C}$)	t_{r}	—	1.6	—	—	0.35	—	μs
Input resistance ($T_{\text{amb}} = +25^{\circ}\text{C}$)	R_{I}	—	50	—	—	5	—	M Ω
Output resistance ($T_{\text{amb}} = +25^{\circ}\text{C}$)	R_{O}	—	5	—	—	1	—	k Ω
Overshoot factor ($V_{\text{I}} = +20\text{ mV}$, $C_{\text{L}} = 100\text{ pF}$, $R_{\text{L}} \geq 5\text{ k}\Omega$, $T_{\text{amb}} = +25^{\circ}\text{C}$)	K_{OV}	—	0	—	—	10	—	%
Differential input capacitance ($T_{\text{amb}} = +25^{\circ}\text{C}$)	C_{ID}	—	2	—	—	2	—	pF

ELECTRICAL CHARACTERISTICS (continued)

UA776M : $-55^{\circ}\text{C} \leq T_{\text{amb}} \leq +125^{\circ}\text{C}$, $V_{\text{CC}} = \pm 3 \text{ V}$

UA776C : $-0^{\circ}\text{C} \leq T_{\text{amb}} \leq +70^{\circ}\text{C}$, $V_{\text{CC}} = \pm 3 \text{ V}$

(Unless otherwise specified)

Characteristic	Symbol	$I_{\text{set}} = 1.5 \mu\text{A}$			$I_{\text{set}} = 15 \mu\text{A}$			Unit
		Min	Typ	Max	Min	Typ	Max	
Input offset voltage $T_{\text{amb}} = +25^{\circ}\text{C}$ $T_{\text{min}} \leq T_{\text{amb}} \leq T_{\text{max}}$	V_{IO} UA776M UA776C UA776M UA776C	— — — —	2 2 — —	5 6 6 7.5	— — — —	2 2 — —	5 6 6 7.5	mV
Input offset current $T_{\text{amb}} = +25^{\circ}\text{C}$ $T_{\text{amb}} = T_{\text{max}}$ $T_{\text{amb}} = T_{\text{min}}$	I_{IO} UA776M UA776C UA776M UA776C	— — — —	0.7 0.7 — —	3 6 5 6 10	— — — — —	2 2 — — —	15 25 15 25 40	nA
Input bias current $T_{\text{amb}} = +25^{\circ}\text{C}$ $T_{\text{amb}} = T_{\text{max}}$ $T_{\text{amb}} = T_{\text{min}}$	I_{IB} UA776M UA776C UA776M UA776C UA776M UA776C	— — — — — —	2 2 — — — —	7.5 10 7.5 10 20 20	— — — — — —	15 15 — — — —	50 50 50 50 120 100	nA
Large signal voltage gain ($V_{\text{O}} = \pm 1 \text{ V}$) $T_{\text{amb}} = +25^{\circ}\text{C}$, $R_{\text{L}} \geq 5 \text{ k}\Omega$ $R_{\text{L}} \geq 75 \text{ k}\Omega$ $T_{\text{min}} \leq T_{\text{amb}} \leq T_{\text{max}}$, $R_{\text{L}} \geq 5 \text{ k}\Omega$ $R_{\text{L}} \geq 75 \text{ k}\Omega$	A_{VD} UA776M UA776C UA776M UA776C	— — 5.10 ⁴ — 2.5.10 ⁴	— — 2.10 ⁵ — 2.10 ⁵	— — — — —	5.10 ⁴ — — — 2.5.10 ⁴	2.10 ⁵ — — — —	— — — — —	V/V
Supply voltage rejection ratio ($R_{\text{S}} \leq 10 \text{ k}\Omega$)	SVR UA776M UA776C	— —	25 25	150 200	— —	25 25	150 200	$\mu\text{V/V}$
Supply current $T_{\text{amb}} = +25^{\circ}\text{C}$ $T_{\text{min}} \leq T_{\text{amb}} \leq T_{\text{max}}$	I_{CC} UA776M UA776C	— — —	13 13 —	20 20 25	— — —	130 130 —	160 170 180	μA
Power consumption $T_{\text{amb}} = +25^{\circ}\text{C}$ $T_{\text{min}} \leq T_{\text{amb}} \leq T_{\text{max}}$	P_{D} UA776M UA776C UA776M UA776C	— — — —	78 78 — —	120 120 150 150	— — — —	780 780 — —	960 1020 1080 1080	μW
Input voltage range	V_{I}	± 1	—	—	± 1	—	—	V
Common-mode rejection ratio ($R_{\text{S}} \leq 10 \text{ k}\Omega$)	CMR	70	86	—	70	86	—	dB
Output short-circuit current ($T_{\text{amb}} = +25^{\circ}\text{C}$)	I_{OS}	—	3	—	—	5	—	mA
Output voltage swing $R_{\text{L}} \geq 5 \text{ k}\Omega$ $R_{\text{L}} \geq 75 \text{ k}\Omega$	V_{OPP} UA776C UA776M	— — ± 2	— — ± 2.4	— — —	± 2 ± 1.9 ± 2	± 2.1 ± 2.1 ± 2.4	— — —	V
Offset voltage adjustment range ($T_{\text{amb}} = +25^{\circ}\text{C}$)	V_{IOR}	—	9	—	—	18	—	mV
Slew rate ($R_{\text{L}} \geq 5 \text{ k}\Omega$, $T_{\text{amb}} = +25^{\circ}\text{C}$)	S_{VO}	—	0.03	—	—	0.35	—	V/ μs
Rise time ($V_{\text{I}} = +20 \text{ mV}$, $C_{\text{L}} = 100 \text{ pF}$, $R_{\text{L}} \geq 5 \text{ k}\Omega$, $T_{\text{amb}} = +25^{\circ}\text{C}$)	t_{r}	—	3	—	—	0.6	—	μs
Input resistance ($T_{\text{amb}} = +25^{\circ}\text{C}$)	R_{I}	—	50	—	—	5	—	M Ω
Output resistance ($T_{\text{amb}} = +25^{\circ}\text{C}$)	R_{O}	—	5	—	—	1	—	k Ω
Overshoot factor ($V_{\text{I}} = +20 \text{ mV}$, $C_{\text{L}} = 100 \text{ pF}$, $R_{\text{L}} \geq 5 \text{ k}\Omega$, $T_{\text{amb}} = +25^{\circ}\text{C}$)	K_{OV}	—	0	—	—	5	—	%
Differential input capacitance ($T_{\text{amb}} = +25^{\circ}\text{C}$)	C_{ID}	—	2	—	—	2	—	pF

INPUT BIAS CURRENT

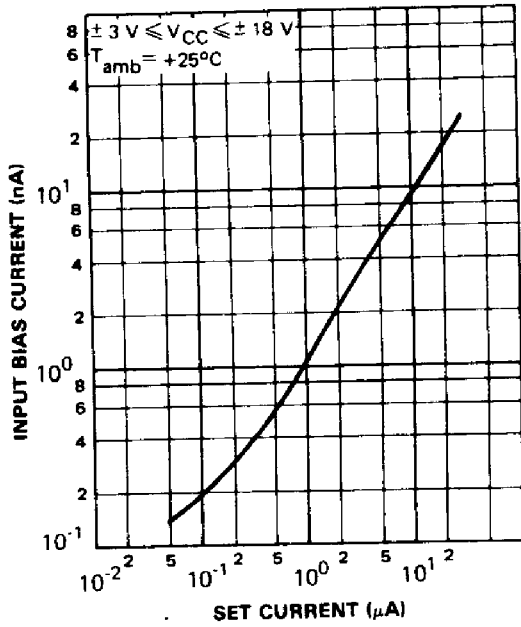

INPUT BIAS CURRENT

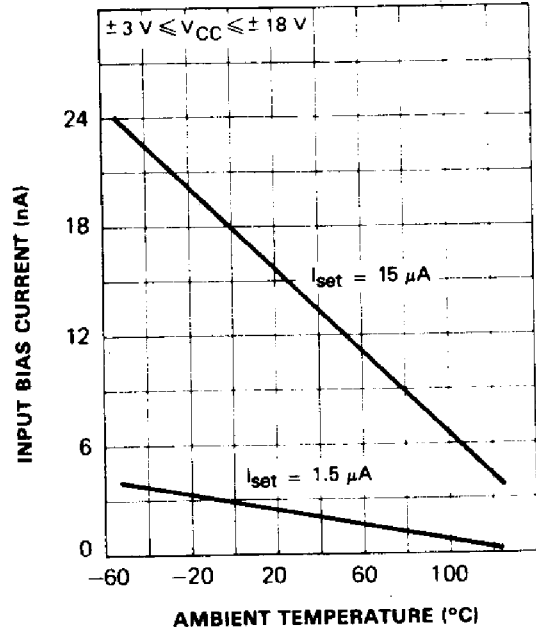

OUTPUT VOLTAGE SWING

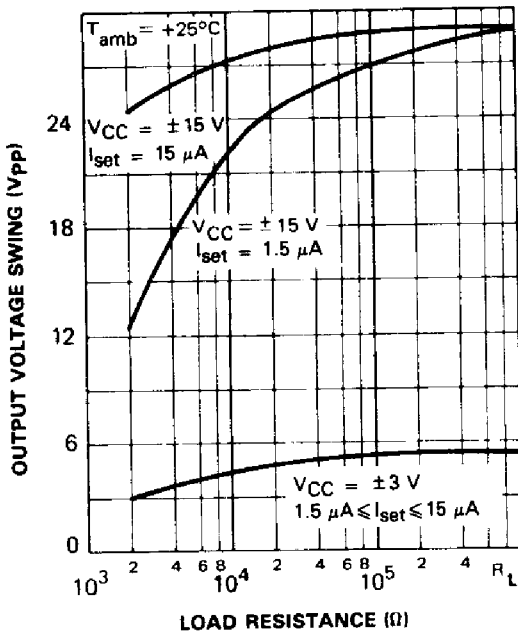

STANDBY SUPPLY CURRENT VERSUS SET CURRENT

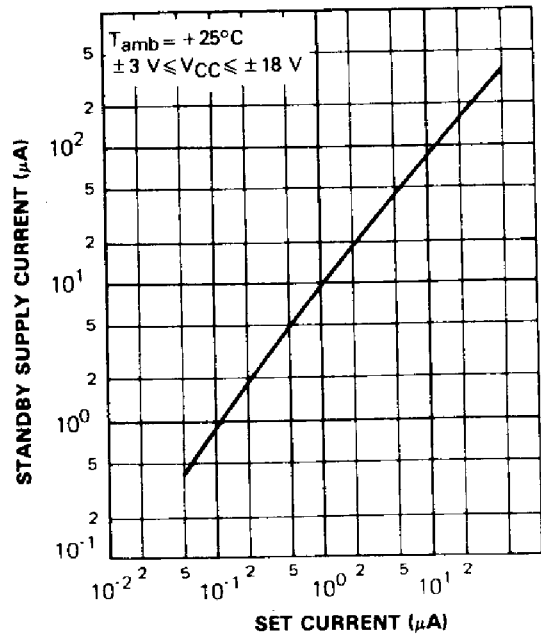

OPEN LOOP VOLTAGE GAIN

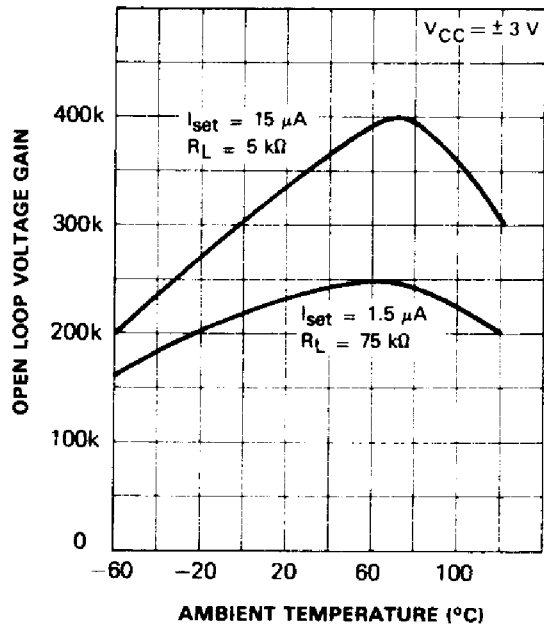

OPEN LOOP VOLTAGE GAIN

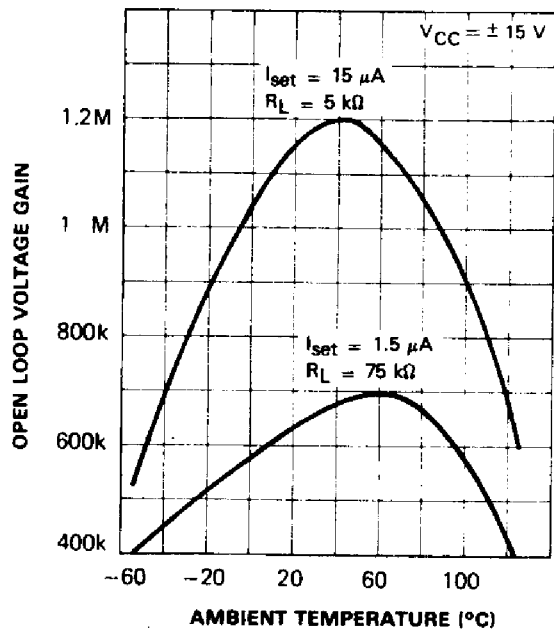

GAIN-BANDWIDTH

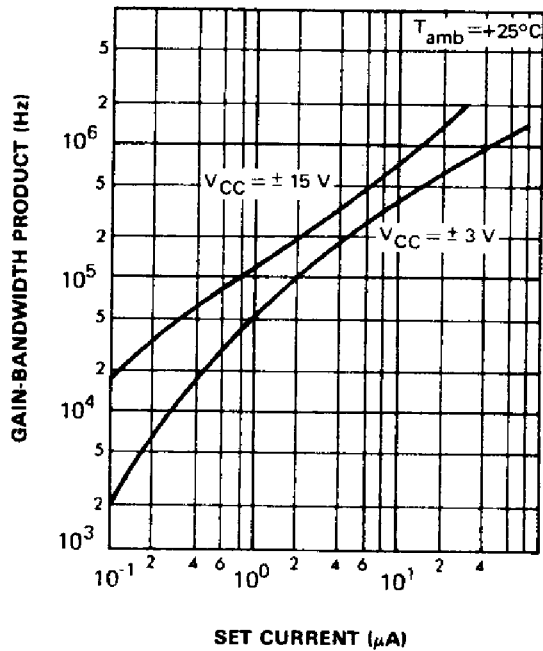

SLEW RATE

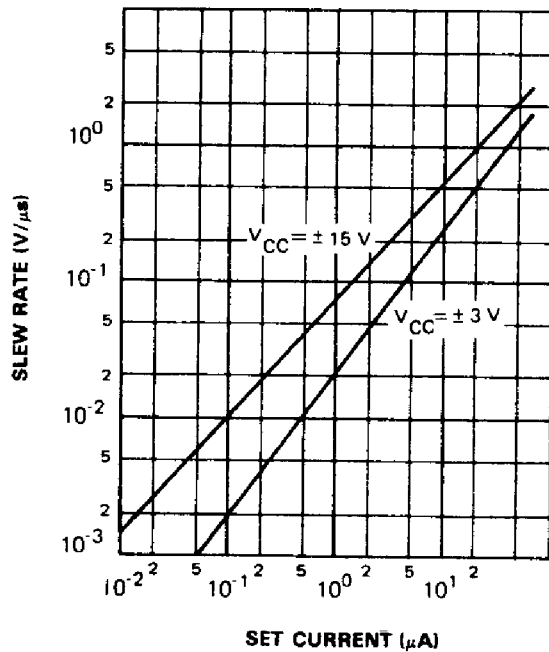

SET RESISTOR vs SET CURRENT

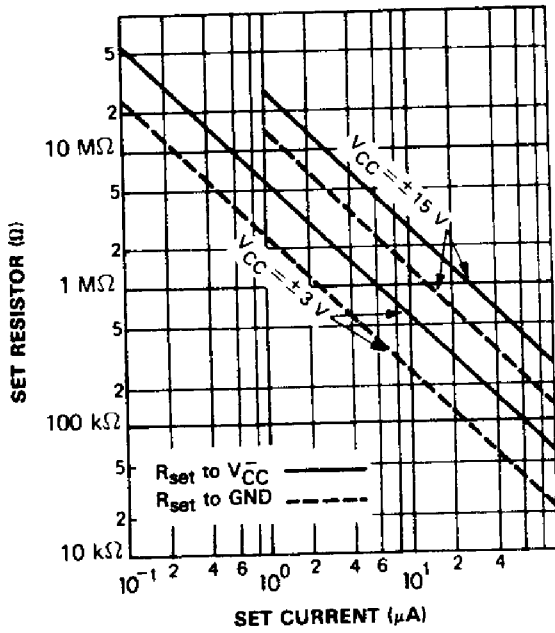

I_{set} EQUATIONS

$$I_{set} = \frac{V_{CC}^+ - 0.7 - V_{CC}^-}{R_{set}}$$

when R_{set} is connected to V_{CC}⁻.

$$I_{set} = \frac{V_{CC}^+ - 0.7}{R_{set}}$$

when R_{set} is connected to ground.

QUIESCENT CURRENT SETTING RESISTOR (I_{set} to V_{CC}⁻)

V _{CC}	I _{set}	
	1.5 μA	15 μA
± 1.5 V	1.7 MΩ	170 kΩ
± 3 V	3.6 MΩ	360 kΩ
± 6 V	7.5 MΩ	750 kΩ
± 15 V	20 MΩ	2 MΩ

Note : The UA776 may be operated with R_{set} connected to ground or V_{CC}⁻.

BIASING CIRCUITS

RESISTOR BIASING

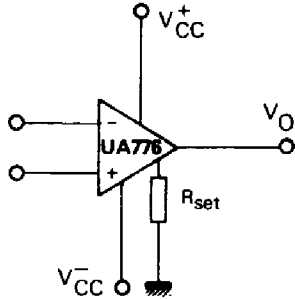

R_{set} connected to ground.

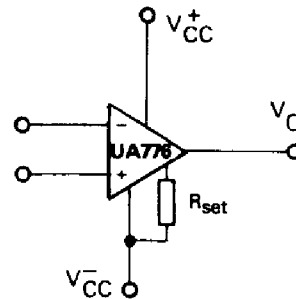

R_{set} connected to V_{CC}^- .
Recommended for: $V_{CC} \leq \pm 6V$

TRANSISTOR CURRENT SOURCE BIASING

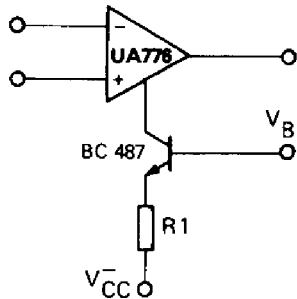

FET CURRENT SOURCE BIASING

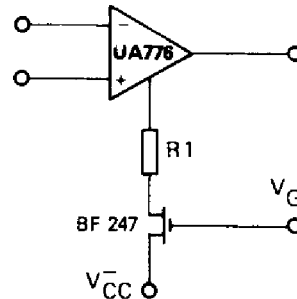

VOLTAGE OFFSET NULL CIRCUIT

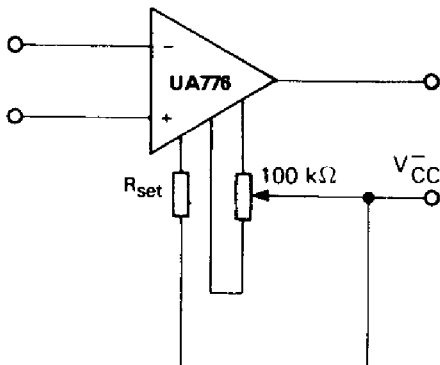

TRANSIENT RESPONSE TIME TEST CIRCUIT

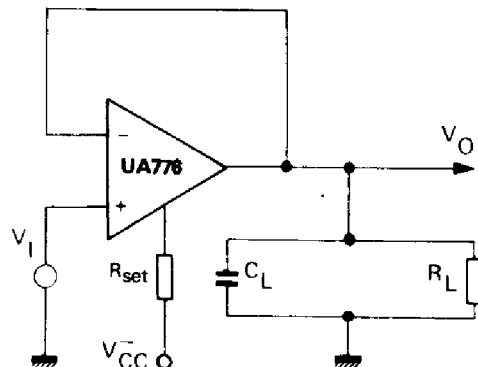

TYPICAL APPLICATIONS

HIGH ACCURACY SAMPLE AND HOLD

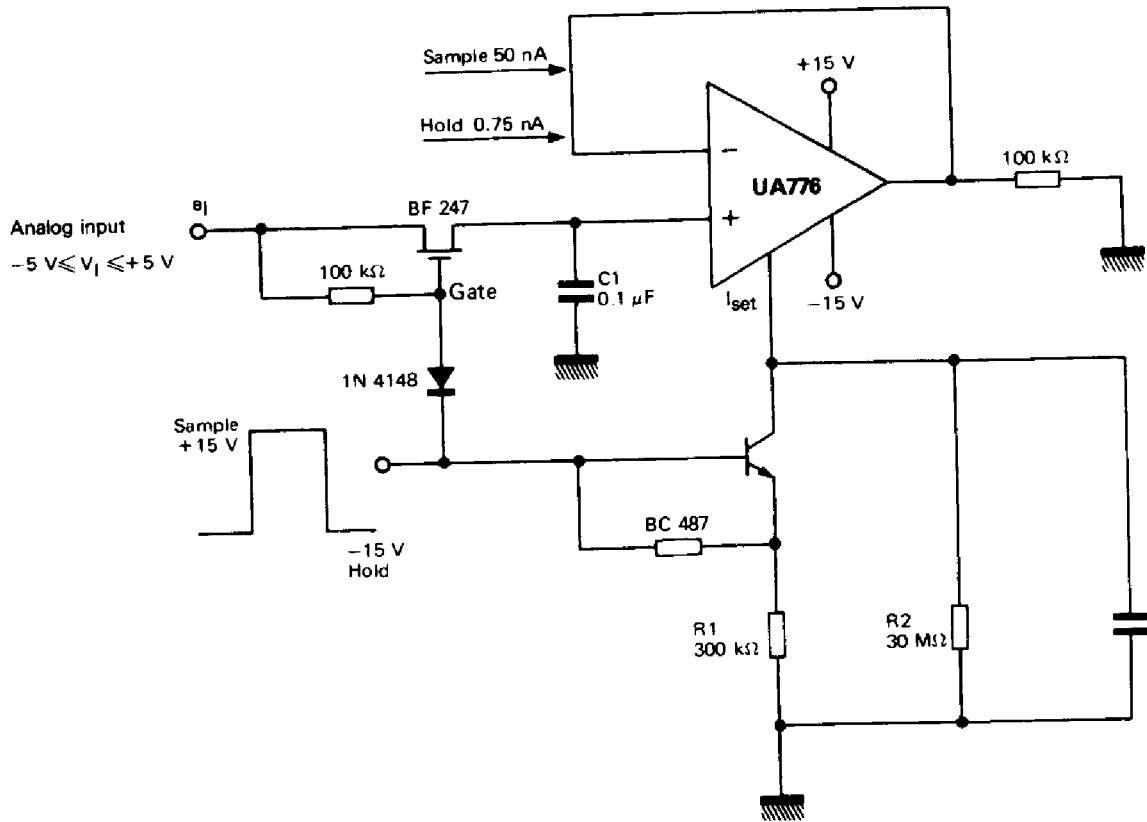

NANO-WATT AMPLIFIER

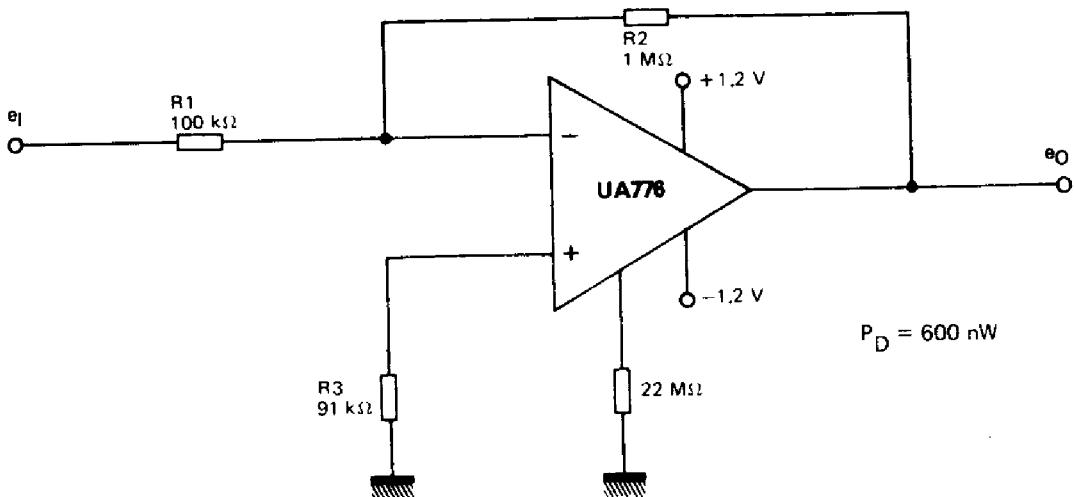

TYPICAL APPLICATIONS (continued)

MULTIPLEXING AND SIGNAL CONDITIONING WITHOUT FETs

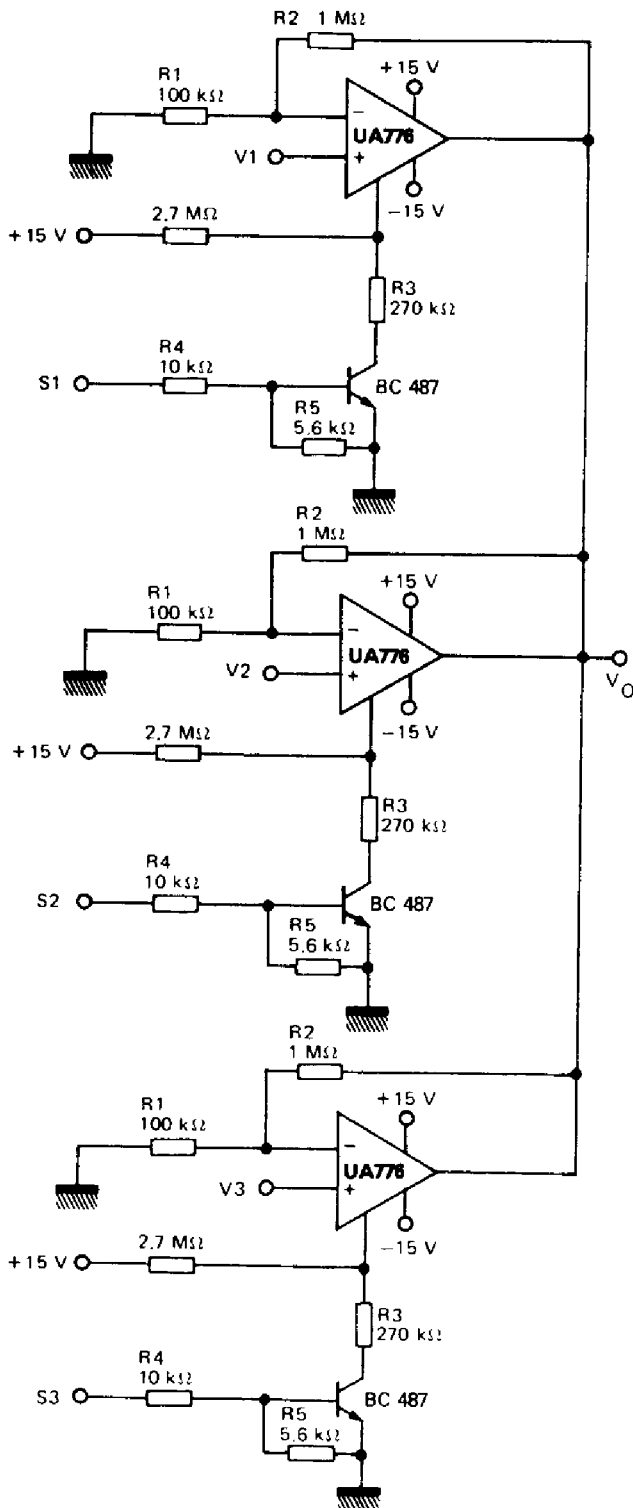

HIGH INPUT IMPEDANCE AMPLIFIER

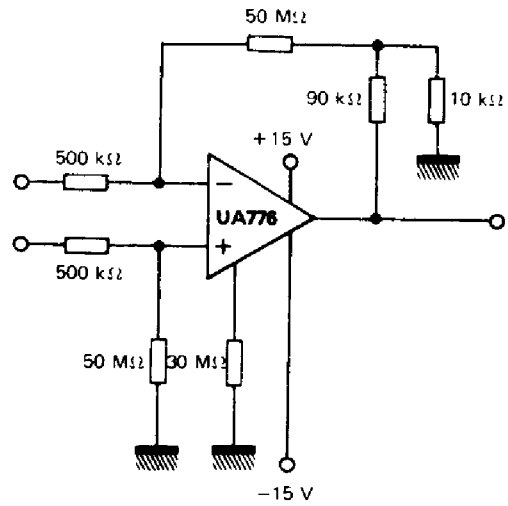

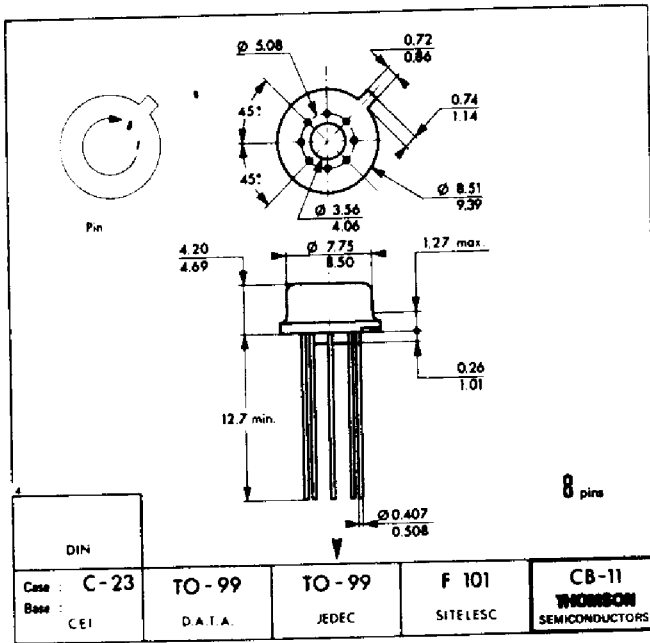

CB-11
(TO-99)



H SUFFIX
METAL CAN

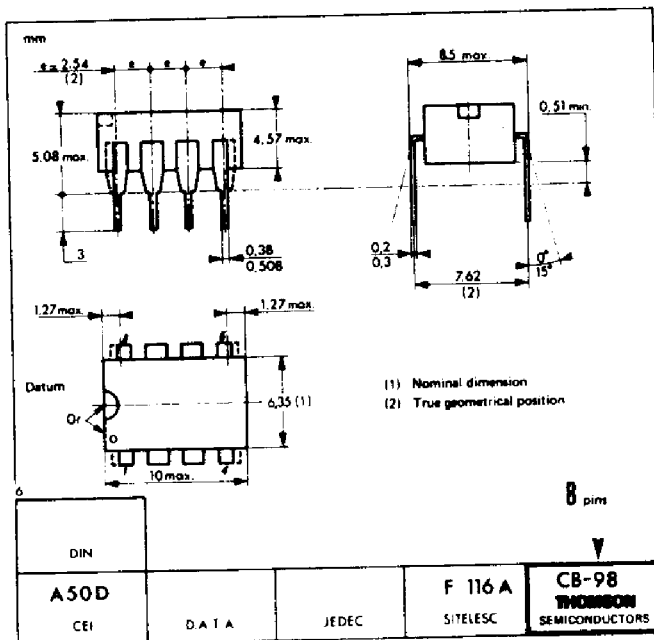

CB-98



DP SUFFIX
PLASTIC PACKAGE
DG SUFFIX
CERDIP PACKAGE