



Product List

SM2958C16, 16 MHz 8KB internal memory MCU
SM2958C25, 25 MHz 8KB internal memory MCU
SM2958C40, 40 MHz 8KB internal memory MCU

Description

The SM2958 product is an 8 - bit single chip micro controller with 32 KB flash embedded. It provides hardware features and a powerful instruction set, necessary to make it a versatile and cost effective controller for those applications demand up to 32 I/O pins or need up to 32 KB flash memory either for program or for data or mixed. To program the flash block, a commercial programmer is capable to do it.

Ordering Information

yyww
SM2958ihhk

yy: year, ww:week
v: version identifier { , A, B, ...}
i: process identifier {C}
hh: working clock in MHz {16, 25, 40}
k: package type postfix {as below table}

Postfix	Package	Pin/Pad Configuration	Dimension
P	40L PDIP	page 2	page 11
J	44L PLCC	page 2	page 12
Q	44L QFP	page 2	page 13

Features

- Working voltage:4.5V through 5.5V
- General 8052 family compatible
- 12 clocks per machine cycle
- 32 KB internal flash memory
- 256 bytes data RAM
- Three 16 bit timers/counters
- Four 8-bit I/O ports
- Full duplex serial channel
- Bit operation instruction
- Page free jumps
- 8-bit unsigned division
- 8-bit unsigned multiply
- BCD arithmetic
- Direct addressing
- Indirect addressing
- Nested interrupt
- Two priority level interrupt
- A serial I/O port
- Power save modes:
Idle mode and power down mode
- Code protection function

Taiwan
4F, No. 1 Creation Road 1,
Science-based Industrial Park,
Hsinchu, Taiwan 30077

TEL: 886-3-579-2926
886-3-579-2988
FAX: 886-3-579-2960
886-3-578-0493

Specifications subject to change without notice,contact your sales representatives for the most recent information.



Pin Configurations

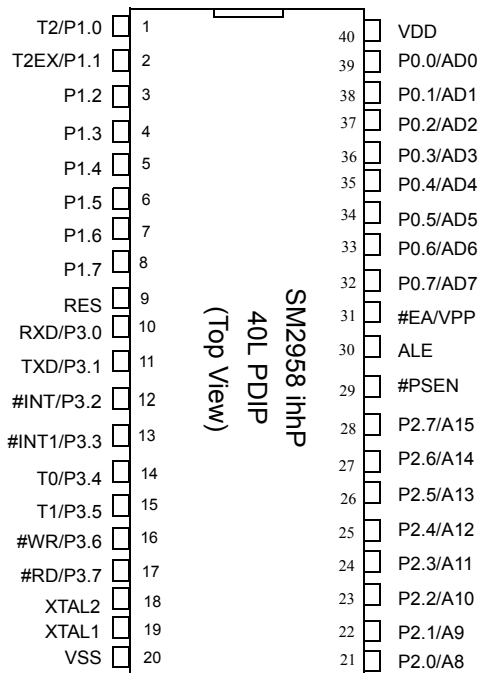
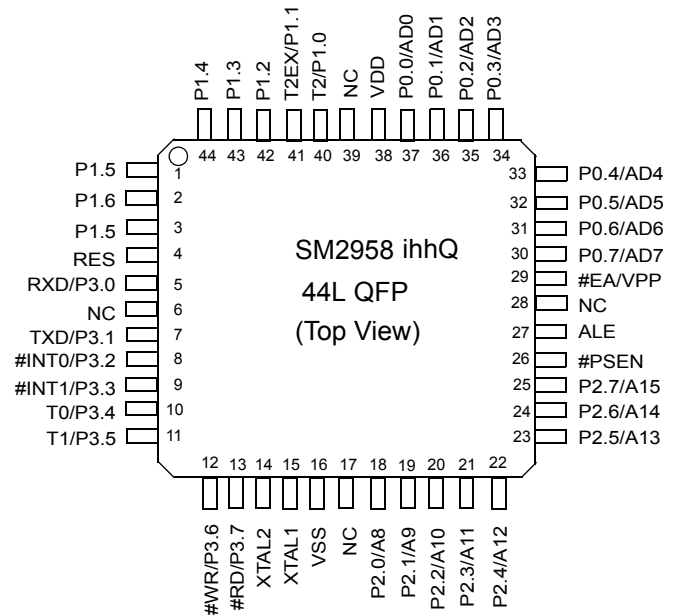
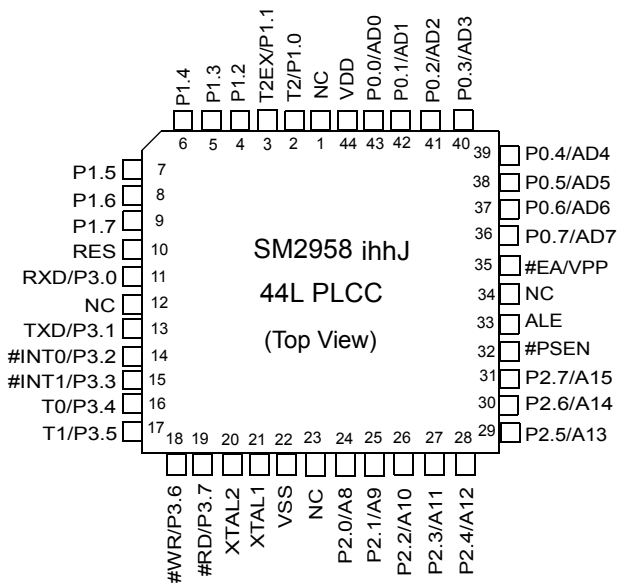

Specifications subject to change without notice, contact your sales representatives for the most recent information.



Block Diagram

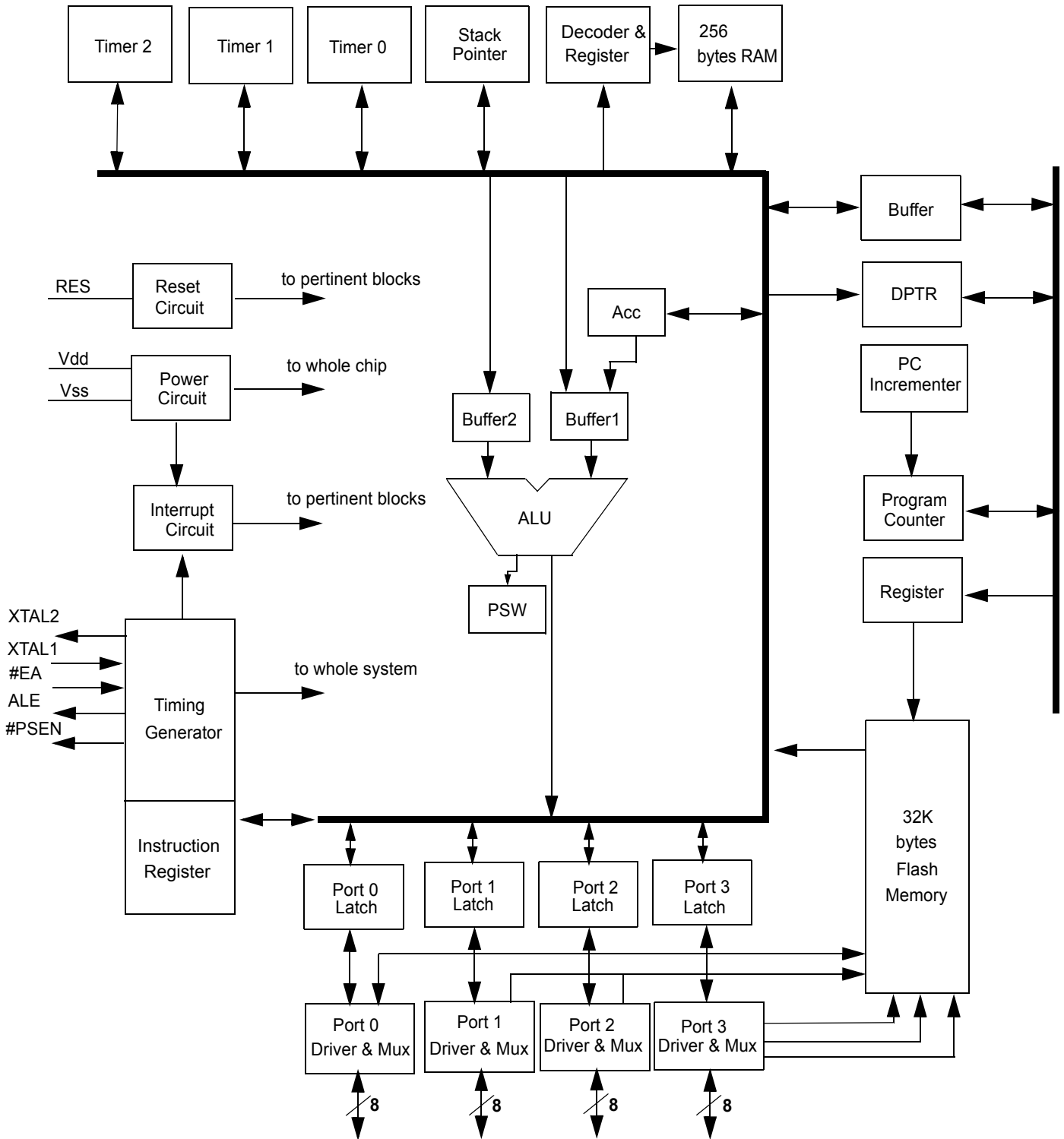



Pin Descriptions

40L PDIP Pin#	44L QFP Pin#	44L PLCC Pin#	Symbol	Active	I/O	Names
1	40	2	T2/P1.0		i/o	bit 0 of port 1 & timer 2
2	41	3	T2EX/P1.1		i/o	bit 1 of port 1 & timer control
3	42	4	P1.2		i/o	bit 2 of port 1
4	43	5	P1.3		i/o	bit 3 of port 1
5	44	6	P1.4		i/o	bit 4 of port 1
6	1	7	P1.5		i/o	bit 5 of port 1
7	2	8	P1.6		i/o	bit 6 of port 1
8	3	9	P1.7		i/o	bit 7 of port 1
9	4	10	RES	H	i	Reset
10	5	11	RXD/P3.0		i/o	bit 0 of port 3 & Receive data
11	7	13	TXD/P3.1		i/o	bit 1 of port 3 & Transmit data
12	8	14	#INT0/P3.2	L/ -	i/o	bit 2 of port 3 & low true interrupt 0
13	9	15	#INT1/P3.3	L/ -	i/o	bit 3 of port 3 & low true interrupt 1
14	10	16	T0/P3.4		i/o	bit 4 of port 3 & Timer 0
15	11	17	T1/P3.5		i/o	bit 5 of port 3 & Timer 1
16	12	18	#WR/P3.6	L/ -	i/o	bit 6 of port 3 & ext. memory write
17	13	19	#RD/P3.7	L/ -	i/o	bit 7 of port 3 & ext. memory read
18	14	20	XTAL2		o	Crystal out
19	15	21	XTAL1		i	Crystal in
20	16	22	VSS			Sink Voltage, Ground
21	18	24	P2.0/A8		i/o	bit 0 of port 2 & bit 8 of ext. memory address
22	19	25	P2.1/A9		i/o	bit 1 of port 2 & bit 9 of ext. memory address
23	20	26	P2.2/A10		i/o	bit 2 of port 2 & bit 10 of ext. memory address
24	21	27	P2.3/A11		i/o	bit 3 of port 2 & bit 11 of ext. memory address
25	22	28	P2.4/A12		i/o	bit 4 of port 2 & bit 12 of ext. memory address
26	23	29	P2.5/A13		i/o	bit 5 of port 2 & bit 13 of ext. memory address
27	24	30	P2.6/A14		i/o	bit 6 of port 2 & bit 14 of ext. memory address
28	25	31	P2.7/A15		i/o	bit 7 of port 2 & bit 15 of ext. memory address
29	26	32	#PSEN	L	o	program storage enable
30	27	33	ALE	-	o	address latch enable
31	29	35	#EA/VPP	L	i	external access & VPP
32	30	36	P0.7/AD7		i/o	bit 7 of port 0 & data/address bit 7 of ext. memory
33	31	37	P0.6/AD6		i/o	bit 6 of port 0 & data/address bit 6 of ext. memory
34	32	38	P0.5/AD5		i/o	bit 5 of port 0 & data/address bit 5 of ext. memory
35	33	39	P0.4/AD4		i/o	bit 4 of port 0 & data/address bit 4 of ext. memory
36	34	40	P0.3/AD3		i/o	bit 3 of port 0 & data/address bit 3 of ext. memory
37	35	41	P0.2/AD2		i/o	bit 2 of port 0 & data/address bit 2 of ext. memory
38	36	42	P0.1/AD1		i/o	bit 1 of port 0 & data/address bit 1 of ext. memory
39	37	43	P0.0/AD0		i/o	bit 0 of port 0 & data/address bit 0 of ext. memory
40	38	44	VDD			Drive Voltage, +5 VCC

Specifications subject to change without notice, contact your sales representatives for the most recent information.



Operating Conditions

Symbol	Description	Min.	Typ.	Max.	Unit.	Remarks
TA	Ambient temperature under bias	0	25	70	C	
VCC5	Supply voltage	4.5	5.0	5.5	V	SM2958C
Fosc 16	Oscillator Frequency	3.0	16	16	MHz	SM2958C16
Fosc 25		3.0	25	25	MHz	SM2958C25
Fosc 40		3.0	40	40	MHz	SM2958C40

DC Characteristics

(12MHz, typical operating conditions, valid for SM2958 series)

Symbol	Parameter	Valid	Min.	Max.	Unit	Test Conditions
VIL1	Input Low Voltage	port 0,1,2,3,4,#EA	-0.5	0.8	V	Vcc=5V
VIL2	Input Low Voltage	RES, XTAL1	0	0.8	V	"
VIH1	Input High Voltage	port 0,1,2,3,4,#EA	2.0	Vcc+0.5	V	"
VIH2	Input High Voltage	RES, XTAL1	70%Vcc	Vcc+0.5	V	"
VOL1	Output Low Voltage	port 0, ALE, #PSEN		0.45	V	IOL=3.2mA
VOL2	Output Low Voltage	port 1,2,3,4		0.45	V	IOL=1.6mA
VOH1	Output High Voltage	port 0	2.4		V	IOH=-800uA
			90%Vcc		V	IOH=-80uA
VOH2	Output High Voltage	port 1,2,3,4,ALE,#PSEN	2.4		V	IOH=-60uA
			90%Vcc		V	IOH=-10uA
IIL	Logical 0 Input Current	port 1,2,3,4		-75	uA	Vin=0.45V
ITL	Logical Transition Current	port 1,2,3,4		-650	uA	Vin=2.0V
ILI	Input Leakage Current	port 0, #EA		± 10	uA	0.45V<Vin<Vcc
R RES	Reset Pulldown Resistance	RES	50	300	Kohm	
C IO	Pin Capacitance			10	pF	Freq=1MHz, Ta=25°C
I CC	Power Supply Current	Vdd		20	mA	Active mode, 12MHz
				6.5	mA	Idle mode, 12MHz
				150	uA	Power down mode

ICC Active mode test circuit

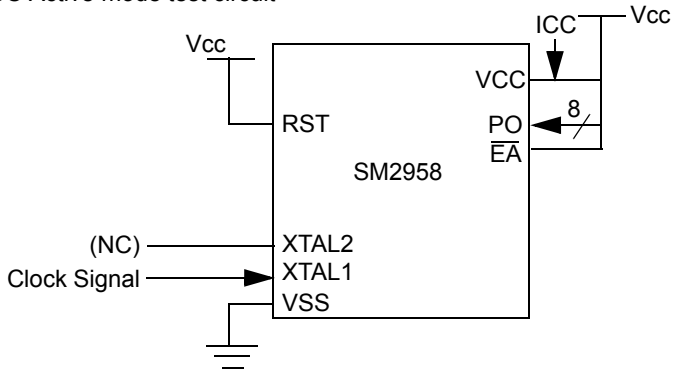

ICC Idle mode test circuit

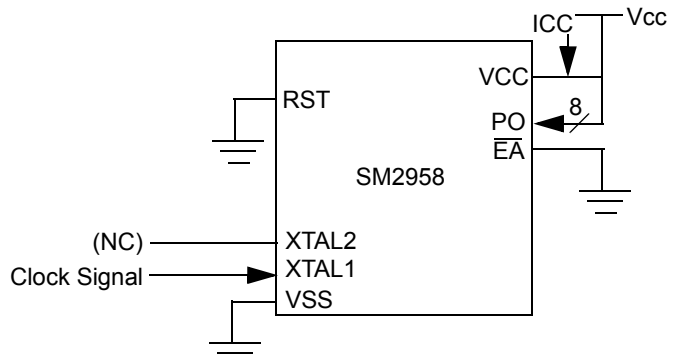

Specifications subject to change without notice, contact your sales representatives for the most recent information.



AC Characteristics

(16/25/40MHz, operating conditions; CL for Port 0, ALE and PSEN Outputs=150pF; CL for all Other Output=80pF)

Symbol	Parameter	Valid Cycle	fosc=16MHz			Variable fosc			Unit	Remarks
			Min.	Typ.	Max	Min.	Typ.	Max		
T LHLL	ALE pulse width	RD/WRT	115			2xT - 10			nS	
T AVLL	Address Valid to ALE low	RD/WRT	43			T - 20			nS	
T LLAX	Address Hold after ALE low	RD/WRT	53			T - 10			nS	
T LLIV	ALE low to Valid Instruction In	RD			240			4xT - 10	nS	
T LLPL	ALE low to #PSEN low	RD	53			T - 10			nS	
T PLPH	#PSEN pulse width	RD	173			3xT - 15			nS	
T PLIV	#PSEN low to Valid Instruction In	RD			177			3xT - 10	nS	
T PXIX	Instruction Hold after #PSEN	RD	0			0			nS	
T PXIZ	Instruction Float after #PSEN	RD			87			T + 25	nS	
T AVIV	Address to Valid Instruction In	RD			292			5xT - 20	nS	
T PLAZ	#PSEN low to Address Float	RD			10			10	nS	
T RLRH	#RD pulse width	RD	365			6xT - 10			nS	
T WLWH	#WR pulse width	WRT	365			6xT - 10			nS	
T RLDV	#RD low to Valid Data In	RD			302			5xT - 10	nS	
T RHDX	Data Hold after #RD	RD	0			0			nS	
T RHDZ	Data Float after #RD	RD			145			2xT + 20	nS	
T LLDV	ALE low to Valid Data In	RD			590			8xT - 10	nS	
T AVDV	Address to Valid Data In	RD			542			9xT - 20	nS	
T LLYL	ALE low to #WR High or #RD low	RD/WRT	178		197	3xT - 10		3xT + 10	nS	
T AVYL	Address Valid to #WR or #RD low	RD/WRT	230			4xT - 20			nS	
T QVWH	Data Valid to #WR High	WRT	403			7xT - 35			nS	
T QVWX	Data Valid to #WR transition	WRT	38			T - 25			nS	
T WHQX	Data hold after #WR	WRT	73			T + 10			nS	
T RLAZ	#RD low to Address Float	RD						5	nS	
T YALH	#WR or #RD high to ALE high	RD/WRT	53		72	T - 10		T + 10	nS	
T CHCL	clock fall time								nS	
T CLCX	clock low time								nS	
T CLCH	clock rise time								nS	
T CHCX	clock high time								nS	
T, TCLCL	clock period			63			1/fosc		nS	

Specifications subject to change without notice, contact your sales representatives for the most recent information.



Application Reference

Valid for SM2958				
X'tal	3MHz	6MHz	9MHz	12MHz
C1	30 pF	30 pF	30 pF	30 pF
C2	30 pF	30 pF	30 pF	30 pF
R	open	open	open	open
X'tal	16MHz	25MHz	33MHz	40MHz
C1	30 pF	15 pF	10 pF	5 pF
C2	30 pF	15 pF	10 pF	5 pF
R	open	62KΩ	6.8KΩ	note

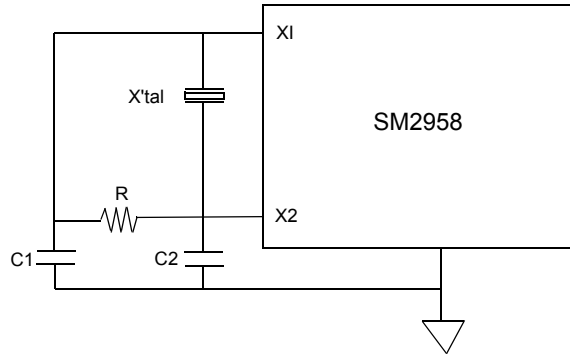

Note: Oscillation circuit may differ with different crystal or ceramic resonator in higher oscillation frequency which is due to each crystal or ceramic resonator has its own characteristics. User should check with the crystal or ceramic resonator manufacturer for appropriate value of external components. Please see SM2958 application note for details.

Data Memory Read Cycle Timing

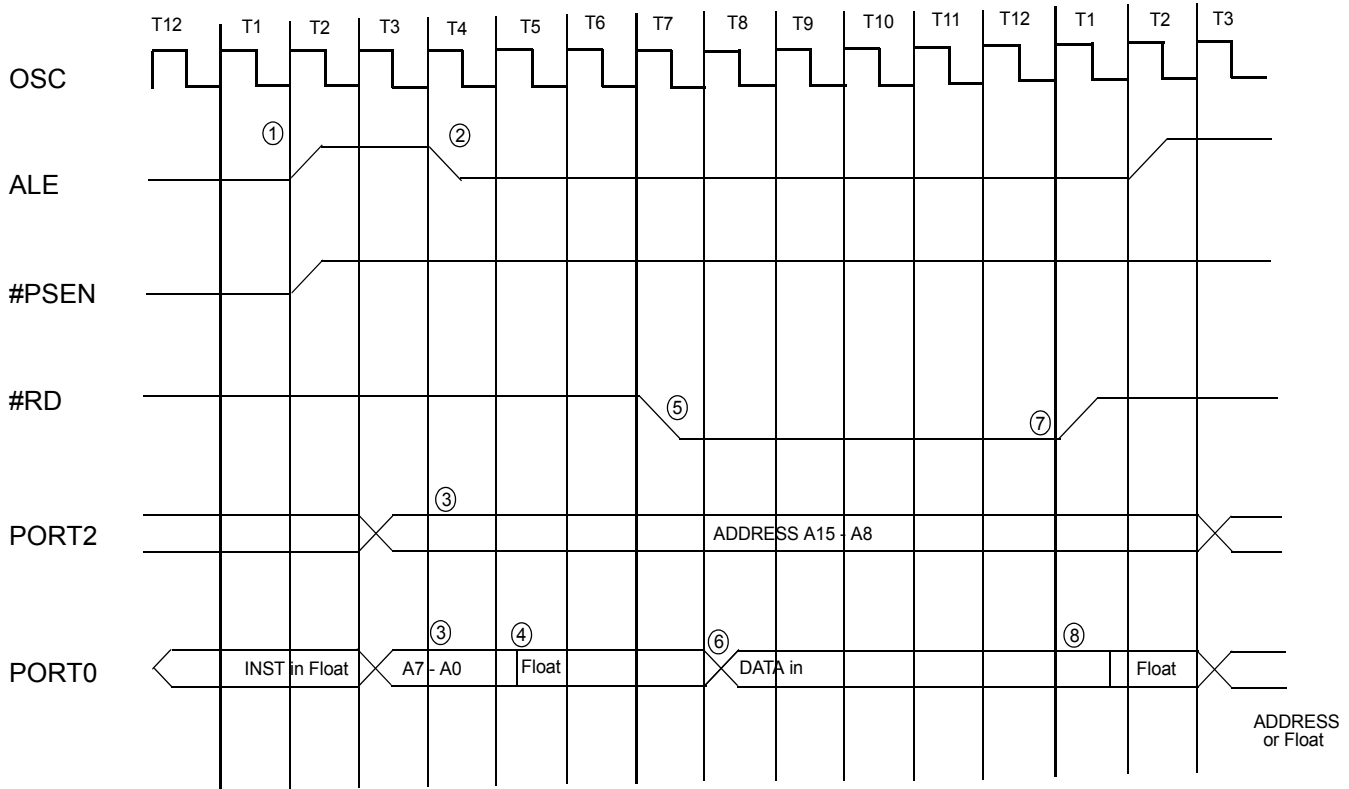

Specifications subject to change without notice, contact your sales representatives for the most recent information.



Program Memory Read Cycle Timing

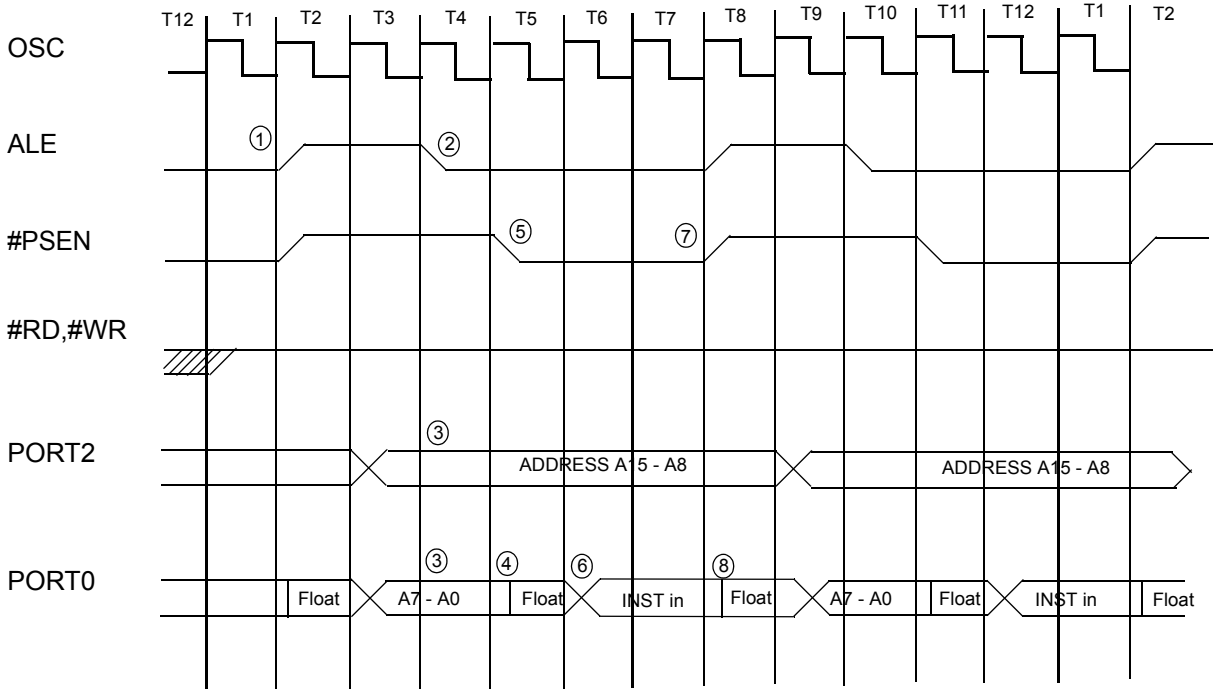

Data Memory Write Cycle Timing

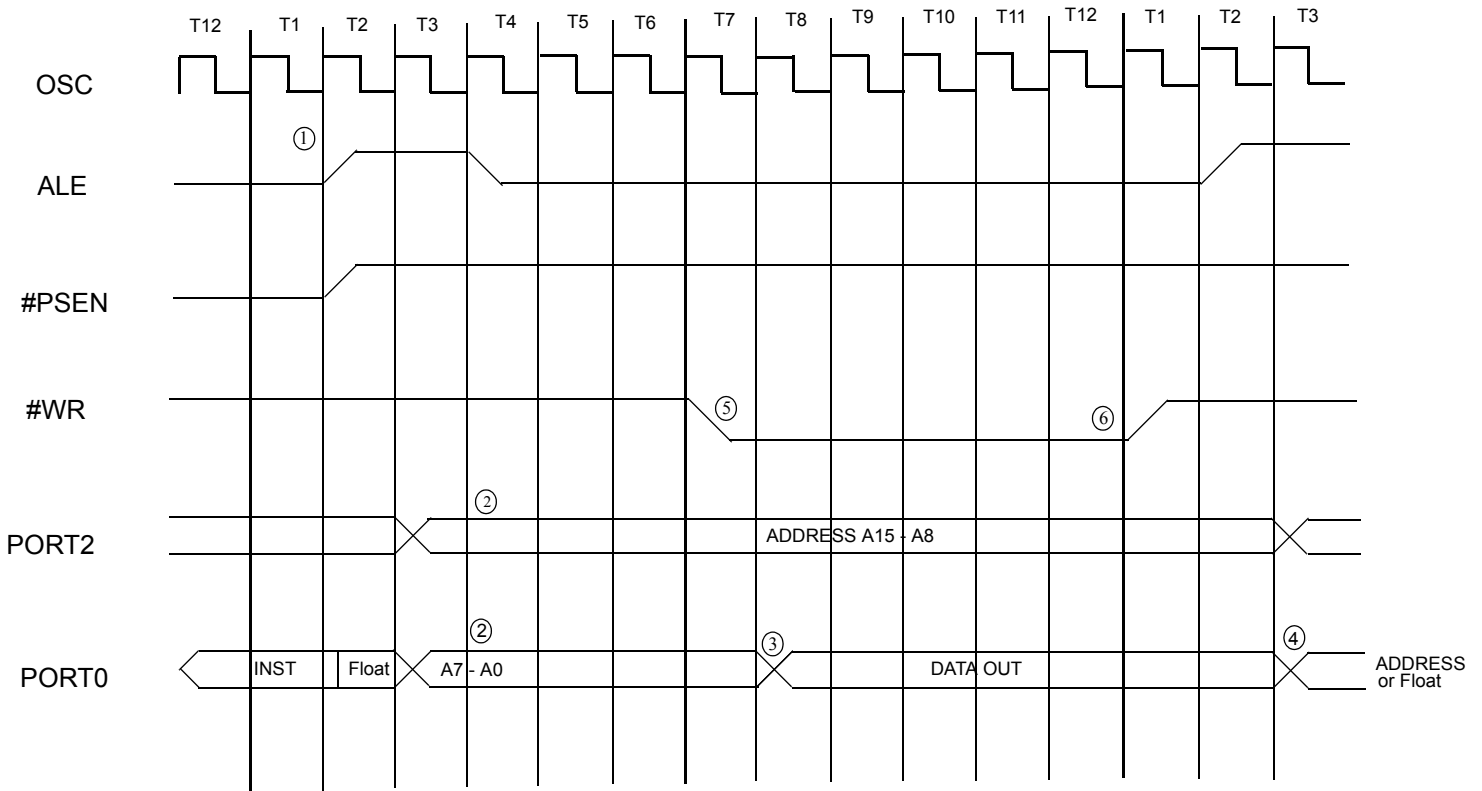

Specifications subject to change without notice, contact your sales representatives for the most recent information.



I/O Ports Timing

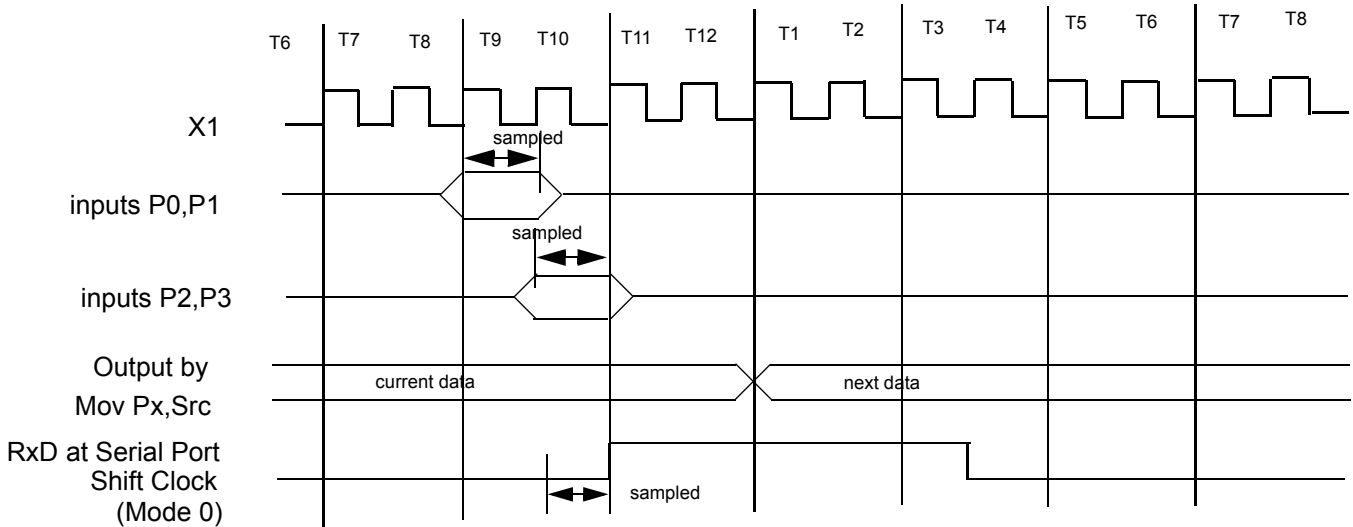

Timing Critical, Requirement of External Clock (Vss=0.0V is assumed)

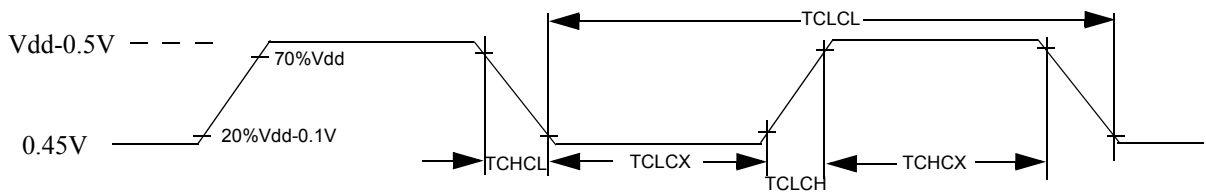

Tm.I External Program Memory Read Cycle

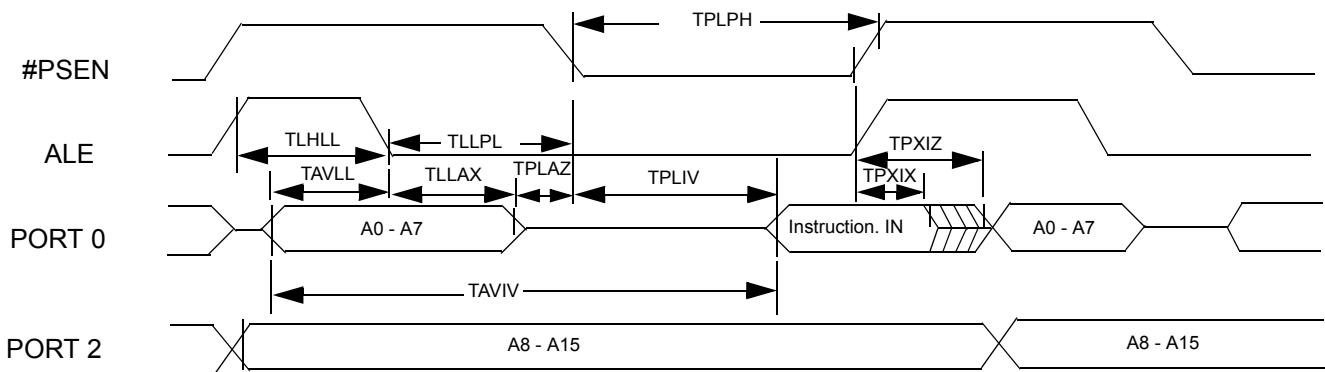

Specifications subject to change without notice, contact your sales representatives for the most recent information.



Tm.II External Data Memory Read Cycle

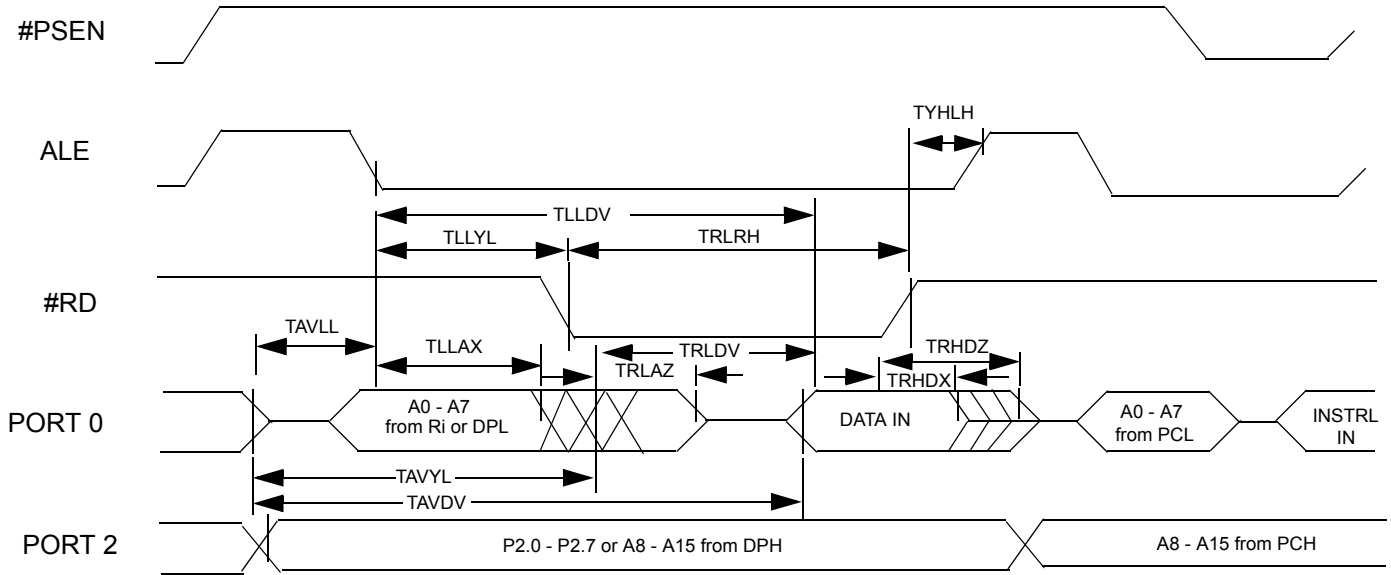

Tm.III External Data Memory Write Cycle

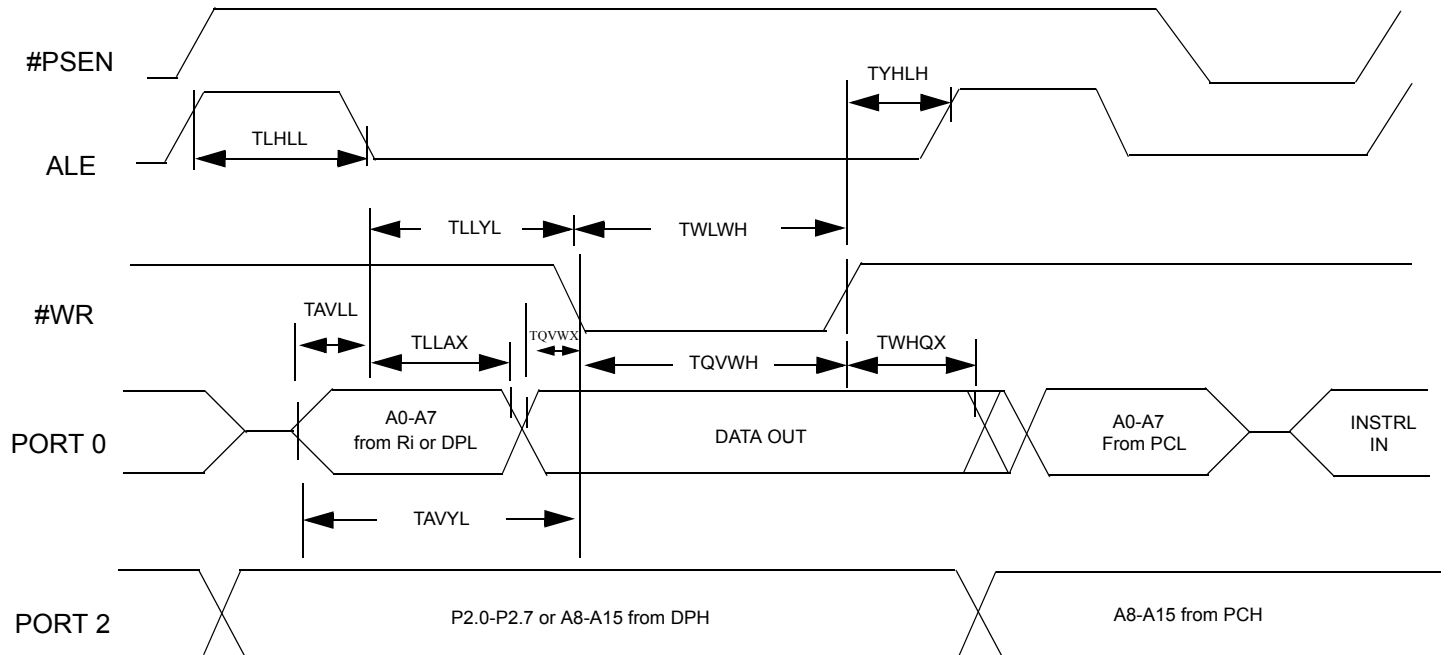



40L 600mil PDIP Information

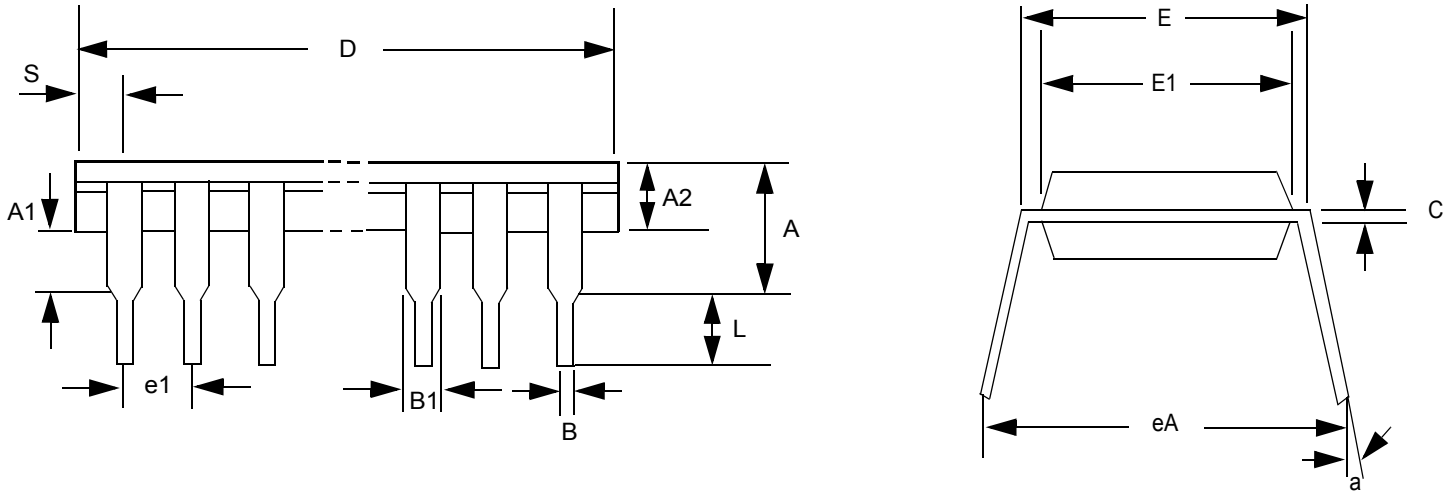

Note:

1. Dimension D Max & include mold flash or tie bar burrs.
2. Dimension E1 does not include inter lead flash.
3. Dimension D & E1 include mold mismatch and are determined at the mold parting line.
4. Dimension B1 does not include dam bar protrusion/infusion.
5. Controlling dimension is inch.
6. General appearance spec. should base on final visual inspection spec.

Symbol	Dimension in inch	Dimension in mm
	minimal/maximal	minimal/maximal
A	- / 0.210	- / 5.33
A1	0.010 / -	0.25 / -
A2	0.150 / 0.160	3.81 / 4.06
B	0.016 / 0.022	0.41 / 0.56
B1	0.048 / 0.054	1.22 / 1.37
C	0.008 / 0.014	0.20 / 0.36
D	- / 2.070	- / 52.58
E	0.590 / 0.610	14.99 / 15.49
E1	0.540 / 0.552	13.72 / 14.02
e1	0.090 / 0.110	2.29 / 2.79
L	0.120 / 0.140	3.05 / 3.56
a	0° / 15°	0° / 15°
eA	0.630 / 0.670	16.00 / 17.02
S	- / 0.090	- / 2.29



44L Plastic Chip Carrier (PLCC)

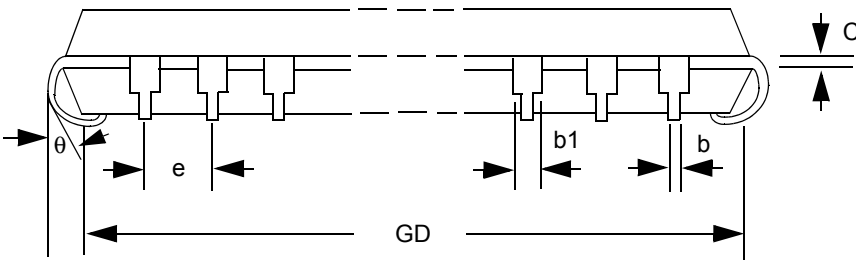
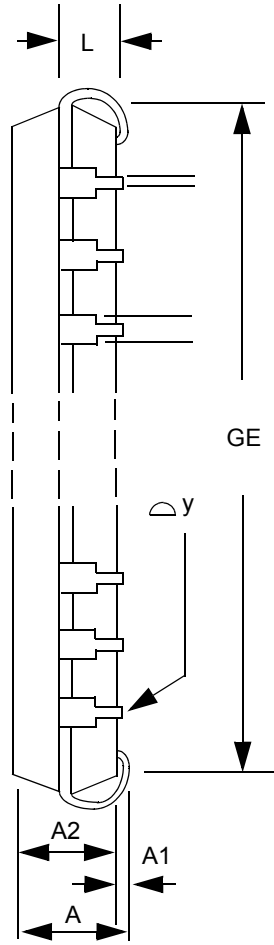
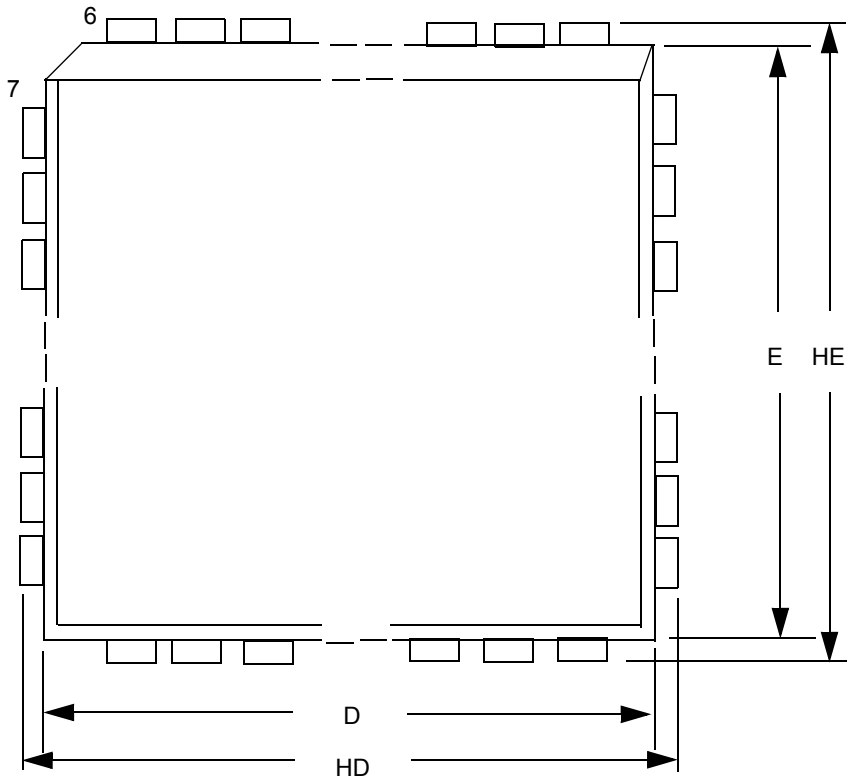

Note:

1. Dimension D & E does not include inter lead flash.
2. Dimension b1 does not include dam bar protrusion/ intrusion.
3. Controlling dimension: Inch
4. General appearance spec. should base on final visual inspection spec.

Symbol	Dimension in	
	inch	mm
	minimal/maximal	minimal/maximal
A	- / 0.185	- / 4.70
A1	0.020 / -	0.51 / -
A2	0.145 / 0.155	3.68 / 3.94
b1	0.026 / 0.032	0.66 / 0.81
b	0.016 / 0.022	0.41 / 0.56
C	0.008 / 0.014	0.20 / 0.36
D	0.648 / 0.658	16.46 / 16.71
E	0.648 / 0.658	16.46 / 16.71
e	0.050 BSC	1.27 BSC
GD	0.590 / 0.630	14.99 / 16.00
GE	0.590 / 0.630	14.99 / 16.00
HD	0.680 / 0.700	17.27 / 17.78
HE	0.680 / 0.700	17.27 / 17.78
L	0.090 / 0.110	2.29 / 2.79
θ	- / 0.004	- / 0.10
Δy	/	/



44L Plastic Quad Flat Package

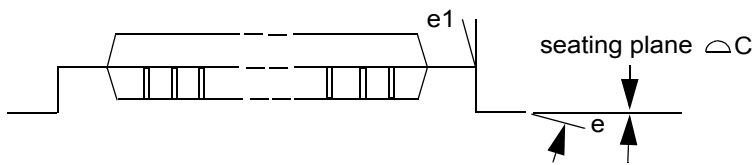
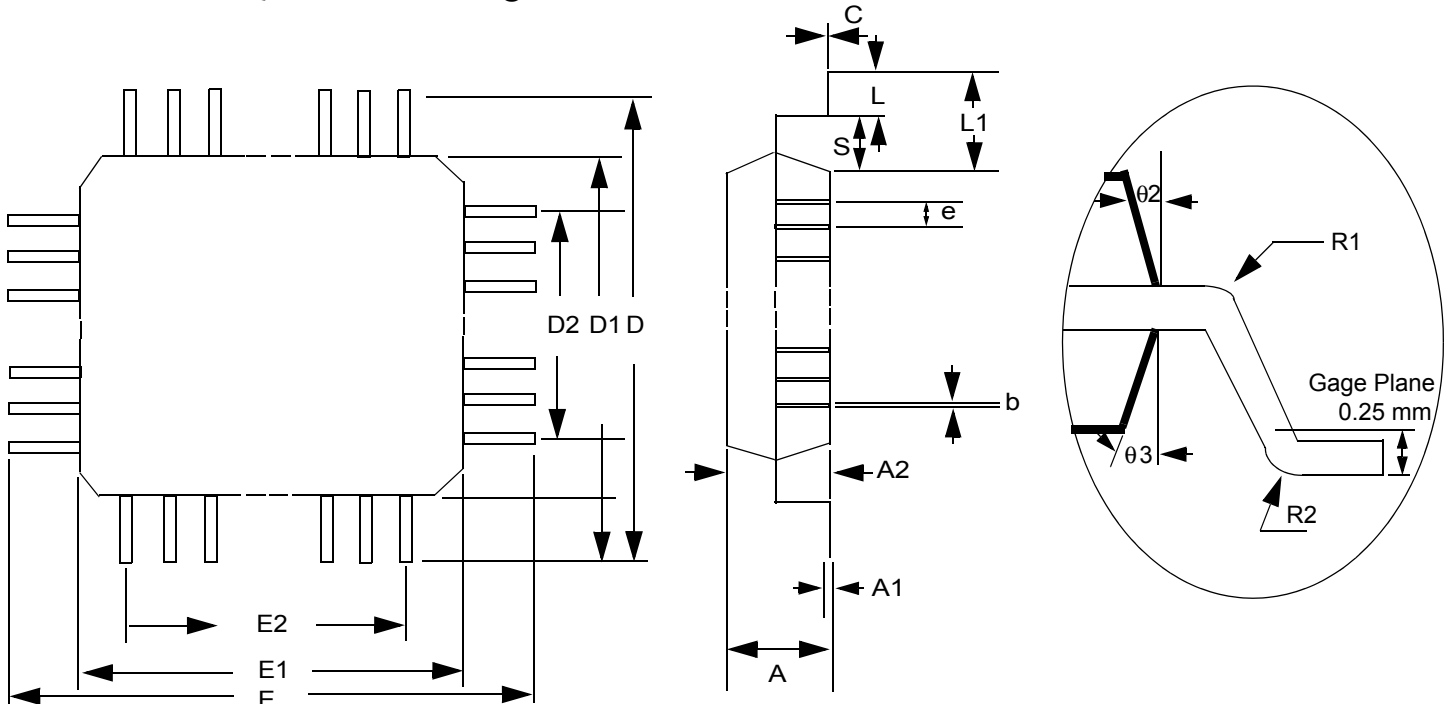

Note:

Dimension D1 and E1 do not include mold protrusion. Allowance protrusion is 0.25mm per side.
 Dimension D1 and E1 do include mold mismatch and are determined datum plane.
 Dimension b does not include dam bar protrusion. Allowance dam bar protrusion shall be 0.08 mm total in excess of the b dimension at maximum material condition. Dam bar cannot be located on the lower radius or the lead foot.

Symbol	Dimension in Inch minimal/maximal	Dimension in mm minimal/maximal
A	- / 0.100	- / 2.55
A1	0.006 / 0.014	0.15 / 0.35
A2	0.071 / 0.087	1.80 / 2.20
b	0.012 / 0.018	0.30 / 0.45
c	0.004 / 0.009	0.09 / 0.20
D	0.520 BSC	13.20 BSC
D1	0.394 BSC	10.00 BSC
D2	0.315	8.00
E	0.520 BSC	13.20 BSC
E1	0.394 BSC	10.00 BSC
E2	0.315	8.00
e	0.031 BSC	0.80 BSC
L	0.029 / 0.041	0.73 / 1.03
L1	0.063	1.60
R1	0.005 / -	0.13 / -
R2	0.005 / 0.012	0.13 / 0.30
S	0.008 / -	0.20 / -
θ	0° / 7°	as left
θ1	0° / -	as left
θ2	10° REF	as left
θ3	7° REF	as left
△ C	0.004	0.10



eMCU writer list		
Company	Contact info	Programmer Model Number
<u>Advantech</u> 7F, No.98, Ming-Chung Rd., Shin-Tien City, Taipei, Taiwan, ROC Web site: http://www.aec.com.tw	Tel:02-22182325 Fax:02-22182435 E-mail: aecwebmaster@advantech.com.tw	LabTool - 48 (1 * 1) LabTool - 848 (1*8)
<u>Caprillon</u> P.O. Box 461 KaoHsiung, Taiwan, ROC Web site: http://www.market.net.tw/~ cap/	Tel:07-3865061 Fax:07-3865421 E-mail: cap@market.net.tw	UNIV2000
<u>Hi-Lo</u> 4F, No. 20, 22, LN, 76, Rui Guang Rd., Nei Hu, Taipei, Taiwan, ROC. Web site: http://www.hilosystems.com.tw	Tel:02-87923301 Fax:02-87923285 E-mai: support@hilosystems.com.tw	All - 11 (1*1) Gang - 08 (1*8)
<u>Leap</u> 6th F1-4, Lane 609, Chunghsin Rd., Sec. 5, Sanchung, Taipei Hsien, Taiwan, ROC Web site: http://www.leap.com.tw	Tel:02-29991860 Fax:02-29990015 E-mail: service@leap.com.tw	ChipStation (1*1) SU - 2000 (1*8)
<u>Xeltek Electronic Co., Ltd</u> 338 Hongwu Road, Nanjing, China 210002 Web site: http://www.xeltek-cn.com	Tel:+86-25-4408399, 4543153-206 E-mail: xelclw@jlonline.com , xelgbw@jlonline.com	Superpro/2000 (1*1) Superpro/680 (1*1) Superpro/280 (1*1) Superpro/L+(1*1)



August 2000

Feedback / Inquiry:

To : SyncMOS Technologies, Inc.	From :
Attn : MKT / Customer Service Dept.	Company :
Fax : 886-3-579-2960	Dept, Section :
: 886-3-578-0493	Position Title :
Tel : 886-3-579-2988	Inquiry Date :
: 886-3-579-2926	Ref No :

: Request customer logo as below:



SM2958 Application Note

■ For normal operation under relatively noisy environment, it is recommended that:

- (1) /PSEN signal being connected to VSS through a pull-low resistor R of value $\sim 47\Omega$ with internal program memory addressing mode used, and/or
- (2) ALE signal being connected to VDD through a pull-high resistor R of value $\sim 100\Omega$ with internal program memory addressing mode used.

Note: If IC operated under normal environment, above circuit modification may not needed.

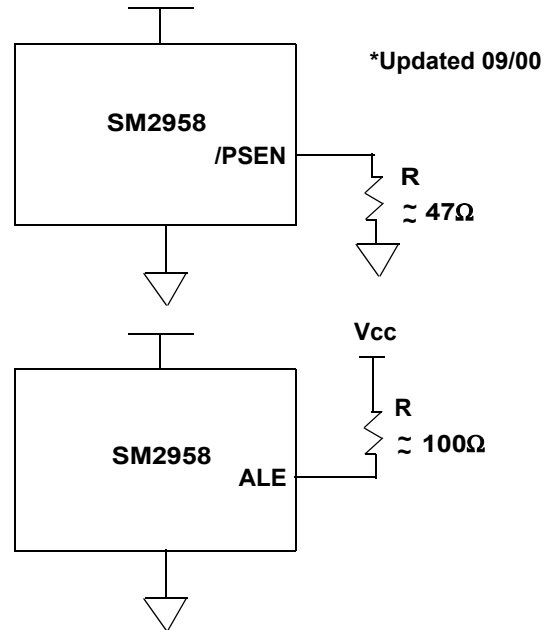

■ 40MHz oscillation circuit, for general quality crystal and resonator

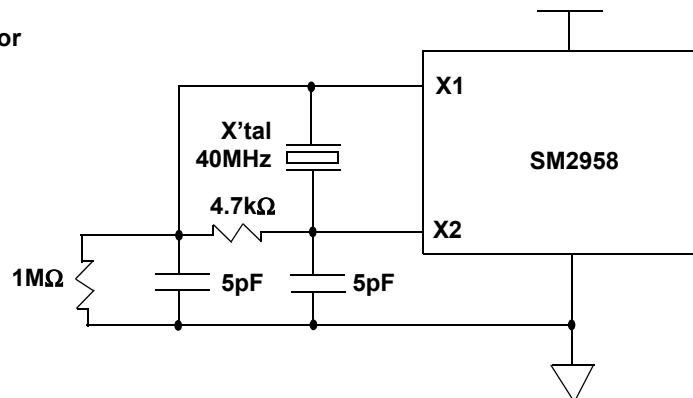

■ Oscillation circuit for very large noise environment. For example, massage machine which driving 10 DC motors in 6MHz oscillation frequency

