

Agilent 5529A Dynamic Calibrator

Data Sheet



System Specifications

Environmental

Operating Temperature: 0 – 40°C (32 – 104°F)
Optics temperature must be stabilized to $\pm 2^\circ\text{C}$ to achieve accuracy specifications.

Power Requirements

Laser Head:

100 – 120 Vac, 48 – 66 Hz, and 400 Hz
220 – 240 Vac, 48 – 66 Hz
50 W (during warmup)
33 W (after warmup)

Electronics (from PC):

2.6 A at 5 Vdc, 15 mA at ± 12 Vdc

Sample Rate

Depends on computer type and setup. Typical rates are listed below.

Computer	Typical rate
486/33	6.7 kHz
486/66	12 kHz
Pentium 90	33 kHz ¹

1. Start Timer: invoked from computer (not from remote).

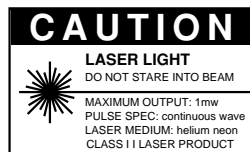

Laser Characteristics

Type: Helium-Neon with automatically tuned Zeeman-split two-frequency output

Warm-up Time: Less than 10 minutes
(4 minutes typical)

Vacuum Wavelength: 632.991354 nm

Wavelength Accuracy: ± 0.1 ppm (± 0.02 ppm of measured wavelength if calibrated with factory calibration, Option UK6)

Short Term (1 hour) Wavelength Stability:
 ± 0.002 ppm typical

Long Term (Lifetime) Wavelength Stability:
 ± 0.02 ppm typical

Output Power: $\geq 180 \mu\text{W}$
(< 1 mW per Class II Laser Product)

Beam Diameter: 6 mm (0.24 in)

Beam Centerline Spacing:
11.0 mm (0.44 in) (input to output aperture)

Safety Classification:

Class II Laser Product conforming to U.S. National Center for Devices and Radiological Health Regulations 21CFR 1040.10 and 1040.11.



Agilent Technologies

Linear Distance, Diagonal, and Velocity Measurement Specifications

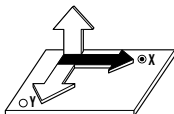

Measurement Range

Up to 40 m (130 ft) with Linear Optics;
Up to 80 m (260 ft) with Long Range Option

Linear Distance and Diagonal Measurement Accuracy

Temperature Range, °C [°F]	10751C/D	In Vacuum†
	Air Sensor	
20° ±0.5°	±1.5 ppm	±0.1 (±0.02) ppm
15 – 25° [59° – 77°]	±1.7 ppm	±0.1 (±0.02) ppm
0 – 40° [32° – 104°]	±3.0 ppm*	±0.1 (±0.02) ppm

* Typical accuracy is ±1.0 ppm with 5 month calibration cycle on Air Sensor.

† Vacuum accuracy is ±0.02 ppm if the laser head is calibrated to MIL-STD 45662A.

Velocity Measurement Accuracy

$$\left[0.015 + \frac{\text{Sample Rate (Hz)}}{10 \text{ kHz}} \times \left(\frac{10 \text{ mm/s}}{\text{Velocity}} + 1 \right) \right] \% \text{ of displayed value}$$

Linear Distance and Diagonal Measurement Performance

Optics	Standard Resolution	Extended Resolution	Maximum Axis Velocity	
			5519A	5519B
Linear Optics (10766A)	10 nm (0.4 μin)	1 nm (0.04 μin)	±0.7 m/s (±28 in/s)	±1 nm/s (±40 in/s)
Plane Mirror Optics (10706A/B)*	5 nm (0.2 μin)	0.5 nm (0.02 μin)	±0.35 m/s (±14 in/s)	±0.5 m/s (±20 in/s)
High Resolution Plane Mirror Optics (10716A)†‡	2.5 nm (0.1 μin)	0.25 nm (0.01 μin)	±0.18 m/s (±7 in/s)	±0.25 m/s (±10 in/s)

* Requires the 10724A Plane Mirror Reflector. Since alignment of these optics is much more sensitive than for linear optics, linear optics are recommended for general use.

‡ Aperture distance of 10716A is 12.7 mm, whereas 5519A is 160 mm.

Angular Measurement Specifications

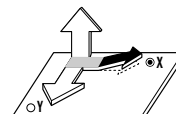

Angle Measurement Accuracy

±0.2% of displayed value
±0.05 arc-seconds per meter of distance traveled
by the linearly moving optic.

Measurement Type

Pitch and yaw

Angle Measurement Resolution

0.05 arc-seconds (standard)
0.005 arc-seconds (extended)

Measurement Range

±10° (rotated about base of optic)
±20° (rotated about center of optic)

Maximum Distance Between Laser Head and Reflector

Up to 15 m (50 ft)

Angular Position Measurement Specifications

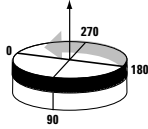

Measurement Type

Rotary and indexing tables or spindles

Indexing Mode

(This is a zero-reference measurement using the 55290A Angular Position Measurement Kit.)

Accuracy: 0.5 sec band +0.2% of displayed reading

Step Size (resolution): 1°

Range: multiple rotations or partial arcs

Laser Measurement Mode

Accuracy: 0.2% of displayed reading. Accuracy can be improved to 0.5 sec by calibrating laser optics with the indexing table (55290A).

Range: ±10°

Setup Requirements

Travel (using +2 mm, -1 mm machine axis, or manual from zero reference)

Indexing Mode

(Interferometer in fixture)

Maximum Lift: 15 mm (2 mm required for fixture)

Flatness and Way Straightness Measurement Specifications



Note: Values do not include effects of surface cleanliness or operator positioning repeatability.

Range: up to 15 m (50 ft)

Flatness Measurement Accuracy

±0.2% of displayed value

±0.05 arc-seconds per meter of distance traveled by the moving optic

Flatness Measurement Resolution (per step)

Footspacing Dimension	Resolution
50.8 mm (2 in)	0.03 micron (1.0 μin)
101.6 mm (4 in)	0.05 micron (2.0 μin)
152.4 mm (6 in)	0.08 micron (3.0 μin)

Reference Plane Accuracy

The uncertainty of a surface plate flatness measurement is bounded by two parallel planes separated by the values below:

Metric Units Mode: 0.03 M² μm

English Units Mode: 0.12 F² μin

Where:

M = length of the surface diagonal in meters

F = length of the surface diagonal in feet

Lateral Offset and Flatness Range

The combination of lateral offset and maximum flatness deviation must not displace the reflector more than ±1.0 mm from the beam path in any direction.

Way Straightness Accuracy

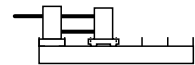

±0.2% of displayed value

±0.05 arc seconds per meter of distance traveled by the moving optics

Straightness and Parallelism Measurement Specifications

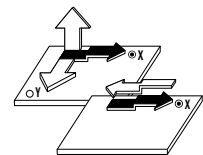

Straightness Measurement Accuracy¹

Overall Accuracy = Optical Reference Accuracy + Measurement Accuracy

1. This is analogous to the traditional straightedge and indicator method of measuring straightness, where Optical Reference Accuracy corresponds to the straightedge accuracy, and Measurement Accuracy corresponds to the indicator accuracy.

Optical Reference Accuracy

Optical reference inaccuracy can be eliminated by using straightedge (mirror) reversal techniques.

Short Range Optics:

Metric units mode: $0.15 M^2 \mu\text{m}$

English units mode: $0.5 F^2 \mu\text{in}$

Long Range Optics:

Metric units mode: $\pm 0.015 M^2 \mu\text{m}$

English units mode: $\pm 0.05 F^2 \mu\text{in}$

Where:

M = distance of travel of the moving optic in meters

F = distance of travel of the moving optic in feet

Measurement Accuracy*

Short Range Optics:

Temperature Range	Displayed Value	
	0 – 10 μm (0 – 400 μin)	10 – 1,500 μm (400 – 60,000 μin)
15 – 25°C	$\pm 3.5\%$	$\pm 1\% \pm 0.25 \mu\text{m}$ (10 μin)
0 – 40°C	$\pm 6\%$	$\pm 1\% \pm 0.5 \mu\text{m}$ (20 μin)

Long Range Optics:

Temperature Range	Displayed Value	
	0 – 100 μm (0 – 4,000 μin)	100 – 1,500 μm (4,000 – 60,000 μin)
15 – 25°C	$\pm 5\%$	$\pm 2.5\% \pm 2.5 \mu\text{m}$ (100 μin)
0 – 40°C	$\pm 7.5\%$	$\pm 2.5\% \pm 5 \mu\text{m}$ (200 μin)

Straightness* Measurement Resolution

	5519A 5519B	5518A
Short Range	0.01 μm (0.4 μin)	0.04 μm (1.4 μin)
Long Range	0.1 μm (4 μin)	(36 μm) (14 μin)

Straightness Measurement Range (Orthogonal to Axial Travel)

$\pm 1.5 \text{ mm}$ (0.060 in)

Axial Separation (Travel)

(distance between the interferometer and the reflector, typical, with proper alignment, 15 – 25°C):

Short Range Optics: 0.1 – 3 m (4 – 120 in)

Long Range Optics: 1 – 30 m (3 – 100 ft)

Squareness Measurement Specifications

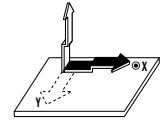

Squareness Measurement Accuracy

Short Range Optics:

Metric Units Mode:

$\pm(1.0 + 0.1 M)$ arc-seconds $\pm 0.01 \theta$

English Unit Mode:

$\pm(1.0 + 0.03 F)$ arc-seconds $\pm 0.01 \theta$

Long Range Optics:

Metric Units Mode:

$\pm(1.0 + 0.01 M)$ arc-seconds $\pm 0.025 \theta$

English Units Mode:

$\pm(1.0 + 0.003 F)$ arc-seconds $\pm 0.025 \theta$

Where:

θ = calculated out-of-square angle in arc-seconds

M = distance of travel of the moving optic in meters

F = distance of travel of the moving optic in feet

A-Quad-B Input

Differential Input Threshold

$\pm 0.5 \text{ V}$ minimum

$\pm 7.0 \text{ V}$ maximum

Differential Input Impedance

100 Ω or High-Z

Input Rate

>100 ns edge-to-edge, or <10 MHz information rate

Example: At maximum speed, A and B both must be <2.5 MHz.

* These specs are not applicable to Timebase Straightness Measurements.

Environmental Compensation

Maximum Compensation Update Rate

0.5 Hz (combined WOL and material temperature compensation)

Wavelength of Light (WOL) Compensation, 10751C/D

Manual: Compensation factor is entered via keyboard

Range: 0.1 to 1.0 ppm

Automatic: Requires 10751C/D Air Sensor. Display of pressure, temperature, relative humidity setting, and computed WOL are provided on the display.

Cable Lengths:

10751C—5 m (16 ft)

10751D—15 m (49 ft)

Operating Range

Temperature: 0 – 40°C (32 – 104°F)

Absolute Pressure: 517.2 – 775.7 mmHg
(10 – 15 psia)

Heat Dissipation: 2 W typical

Time Constants:

Temperature: 3 min. typical

Pressure: <1s typical

Material Temperature Compensation, 10757D/E/F

Manual: User-entered via keyboard

Range: 0 – 50°C (32 – 122°F)

Automatic: Requires 1 to 3 Agilent 10757D/E/F Material Temperature Sensors. Display of individual readings and average of all connected sensors are provided on display.

10757D/E/F Material Temperature Sensor:

Integrated Circuit type. Mounted in remote, oil immersible “button” with magnetic base.

Cable Lengths:

10757D—5 m (16 ft)

10757E—15 m (49 ft)

10757E—25 m (82 ft)

Maximum Sensor Error

(12 month calibration intervals) $\pm 0.35^\circ\text{C}$, $\pm 0.10^\circ\text{C}$ with calibration matching to Agilent 10886A.

Time Constant: 15 s typical

Material Expansion Coefficient:

Range: -100.0 to $+100.0$ ppm per $^\circ\text{C}$ or $^\circ\text{F}$, manually entered.

Personal Computer

The Agilent 5529A requires an IBM PC-compatible computer with the following minimum configuration:

- 486/33 MHz processor
- 8 MB RAM
- 1½ ISA slots
- 3½" floppy disk drive
- Windows® 3.1 and/or Windows 95

A faster, more powerful computer enhances 5529A operation.

System Component Dimensions and Weights

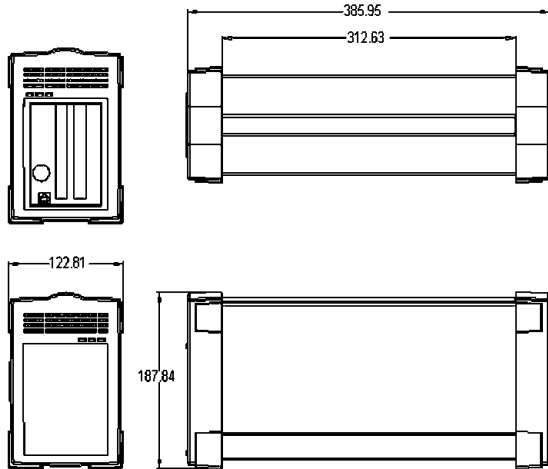

Agilent 55292A USB Expansion Module

Power requirements:

Included: one switching mode power supply input
100-240V, 47-63Hz, 1A

Environmental:

Operating Range: 0-40 °C

Minimum Requirements:

IBM compatible Computer with Windows 98 or Windows 2000 Installed

- 64Mb of RAM
 - CD-ROM Drive
 - USB version 1.1, 12Mb/sec internal port
- note: add on adapters are not supported

Dedicated Host for Agilent 10887A PC Calibrator Board and 10886A PC Compensation Board **Only!!**

Shipping Weight: 2.1 Kgs

For more information on USB, visit <http://www.usb.org/index.html>.

Head/Tripod

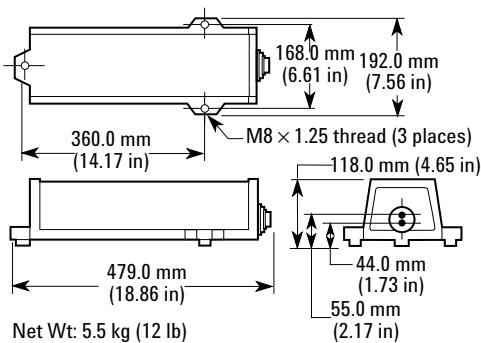

Agilent 5519A/B Laser Head

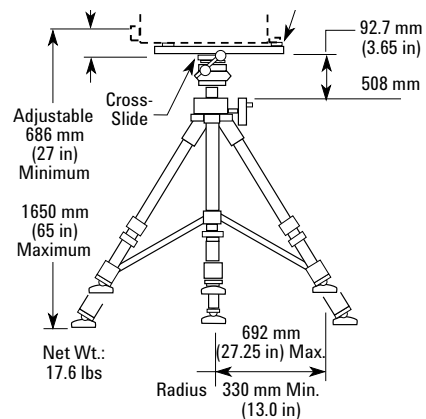

Agilent 10753B laser Tripod

Linear Optics

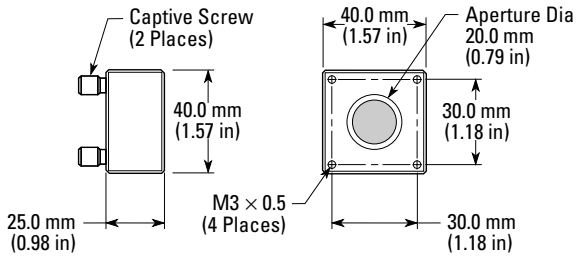

Net Wt: 224 g (0.5 lb)

Agilent 10767A Linear Retroreflector

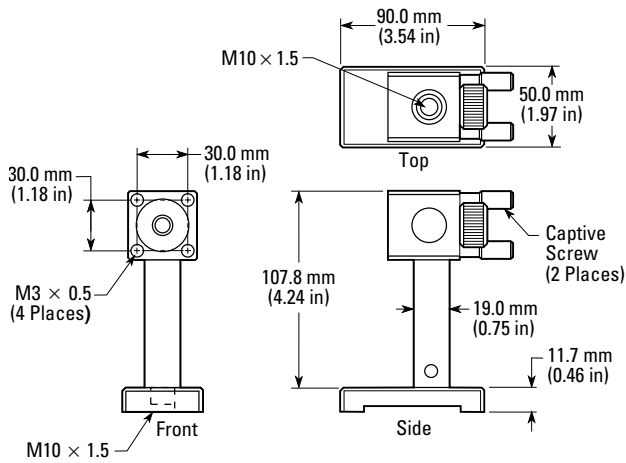

Agilent 10785A Height Adjuster/Post, 10784A Base

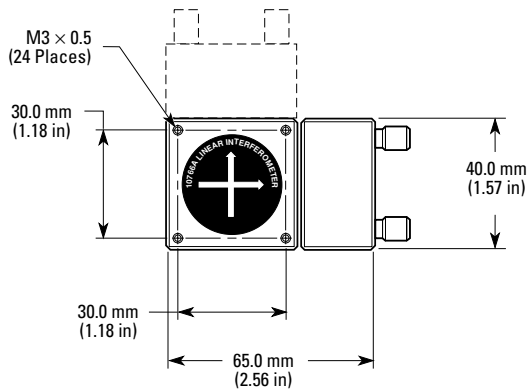

Net Wt: 5.36 g (1.2 lb)

Note
Dotted outline shows possible 10767A
retroreflector mounting positions.

Agilent 10766A/10767A Interferometer Combination

Angular Optics

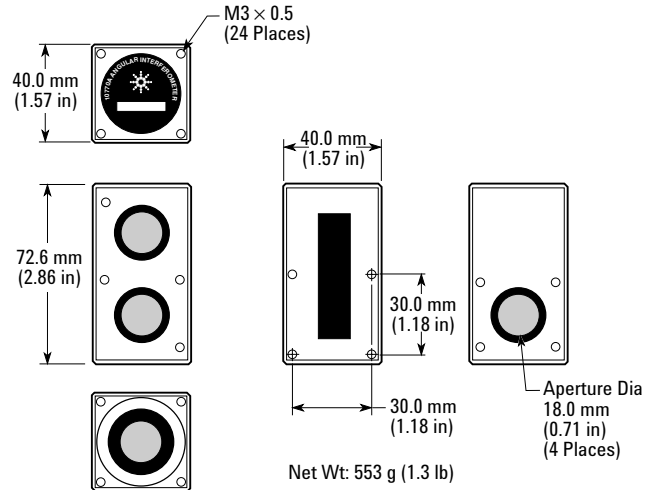

Agilent 10770A Angular Interferometer

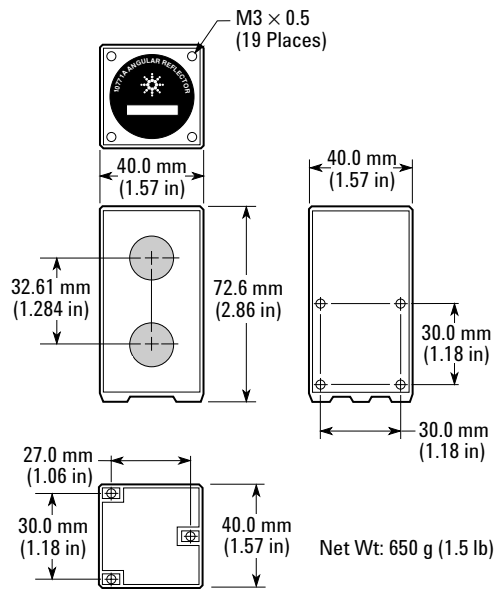

Agilent 10771A Angular Reflector

Flatness Accessories

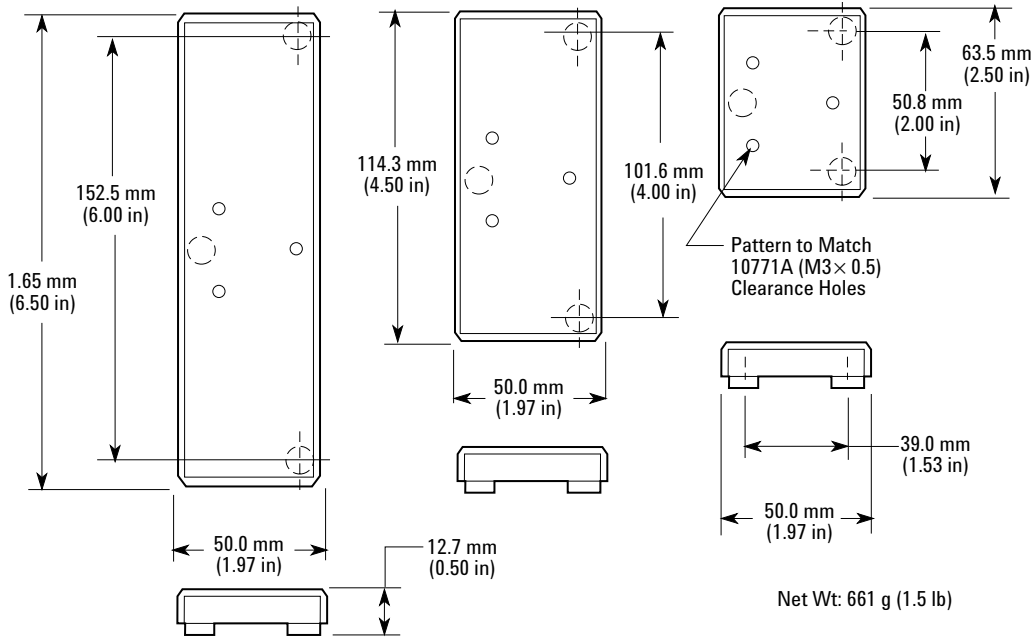

Agilent 10759A Foot Spacing Kit

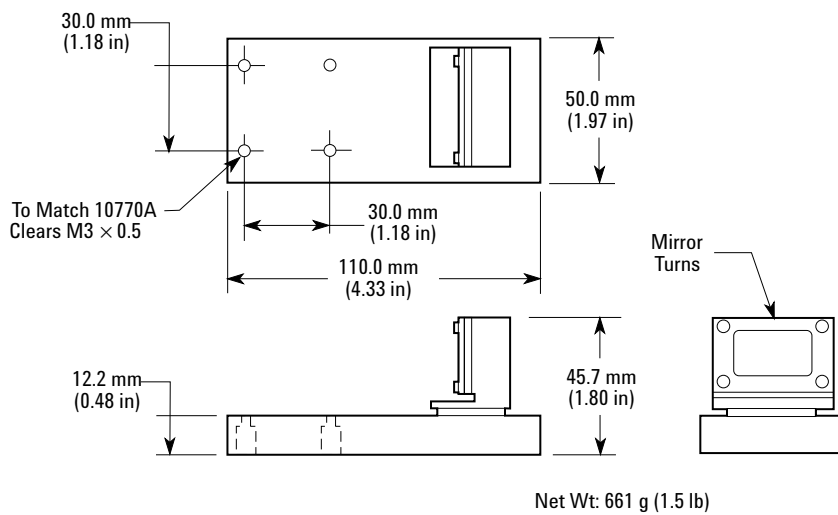

Agilent 10773A Flatness Mirror

Straightness/Squareness Optics

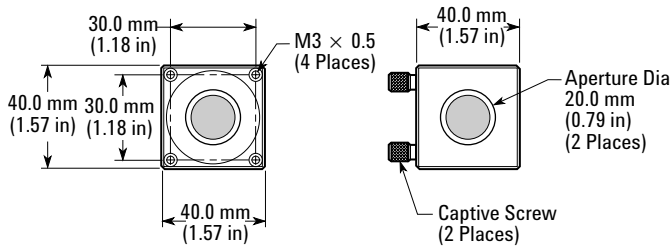

Net Wt: 510 g (1.2 lb) w/Mount

Agilent 10772A Tuning Mirror

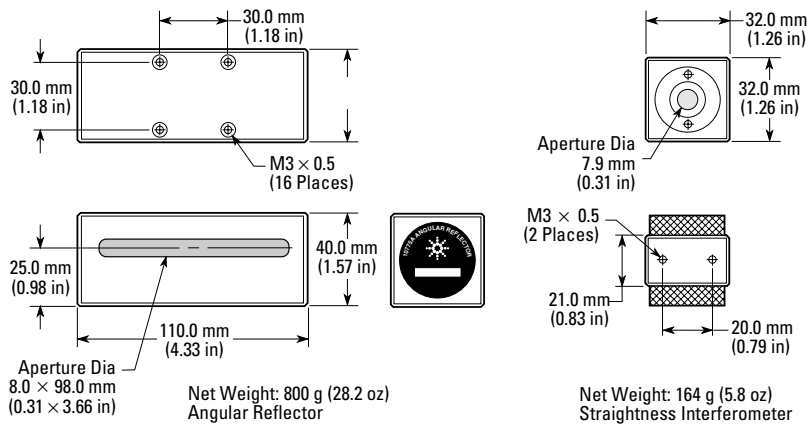

Net Weight: 800 g (28.2 oz)
Angular Reflector

Net Weight: 164 g (5.8 oz)
Straightness Interferometer

Agilent 10774A Short Range Straightness Optics/10775A Long Range Straightness Optics

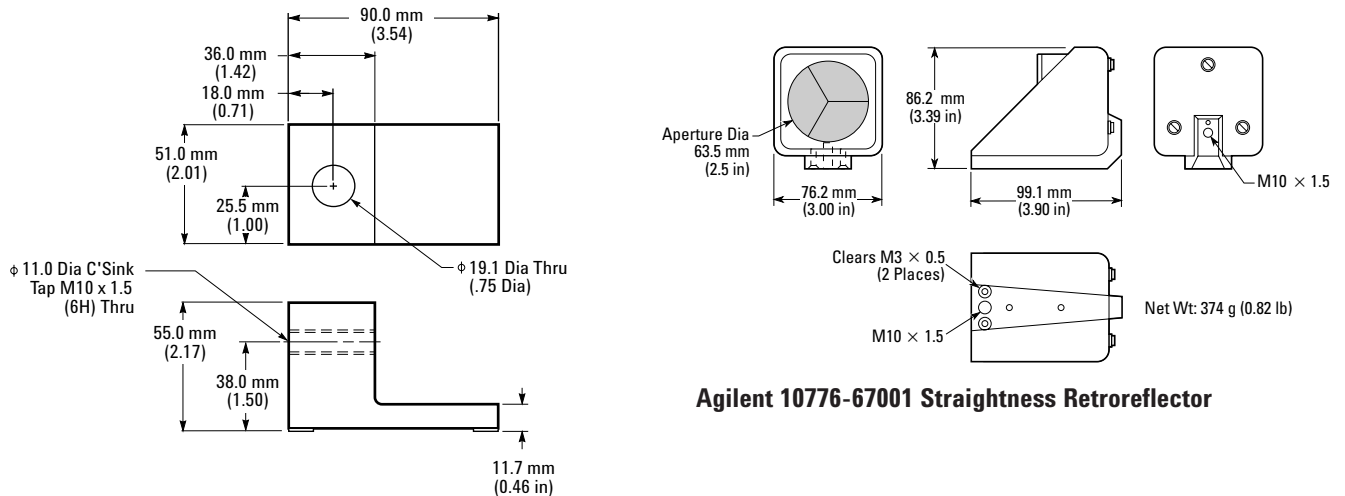

Agilent 10776-67001 Straightness Retroreflector

Agilent 10776A Straightness Mount

Straightness/Squareness Optics, continued

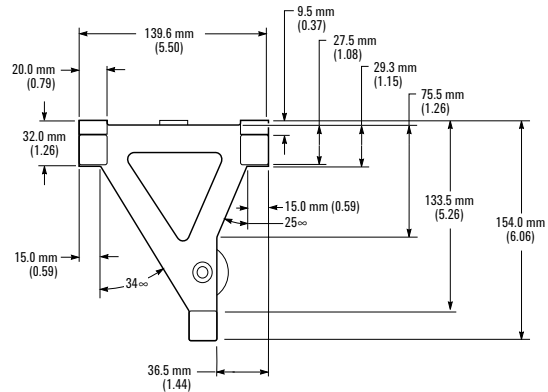
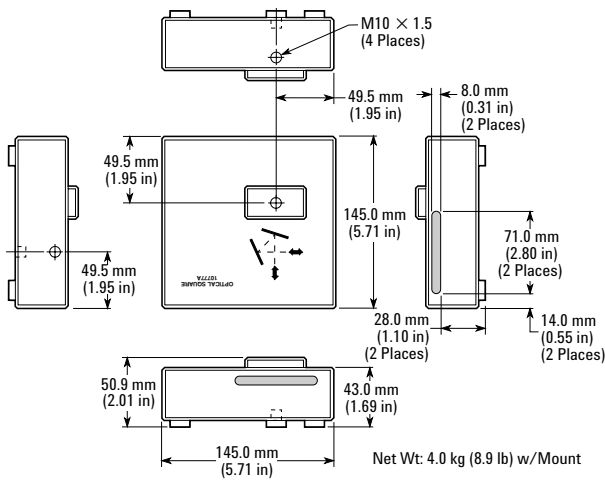

Agilent 10777A Optical Square

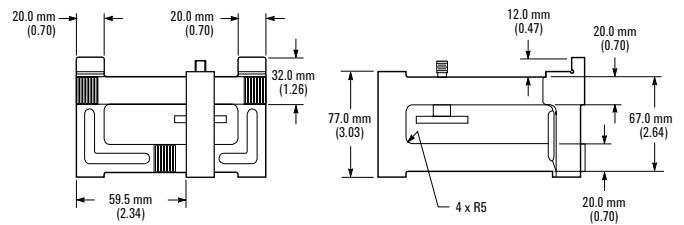

Agilent 10777-20007 Optical Square Base

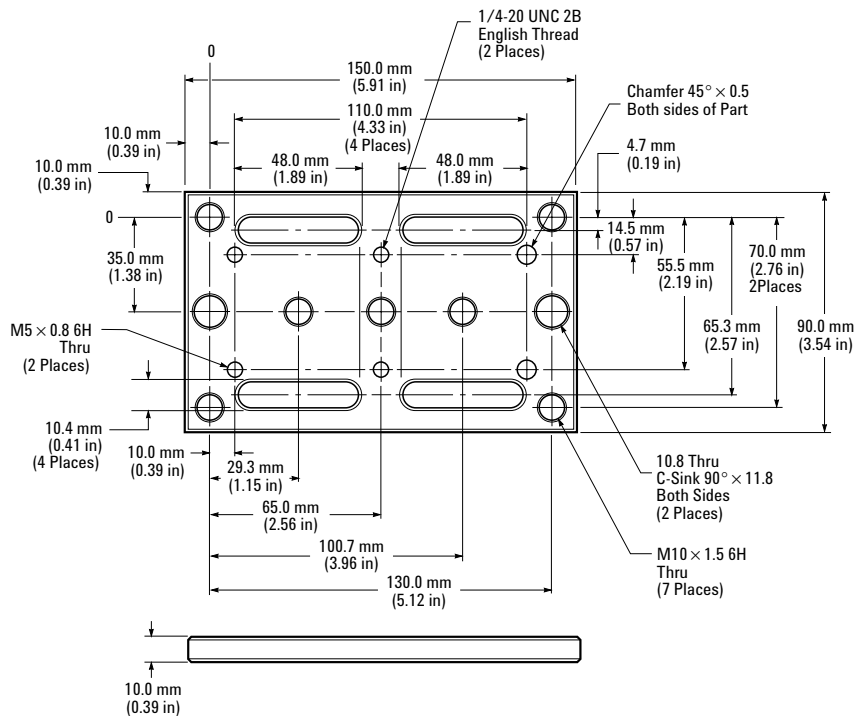

Agilent 10768-20214 Base - Large

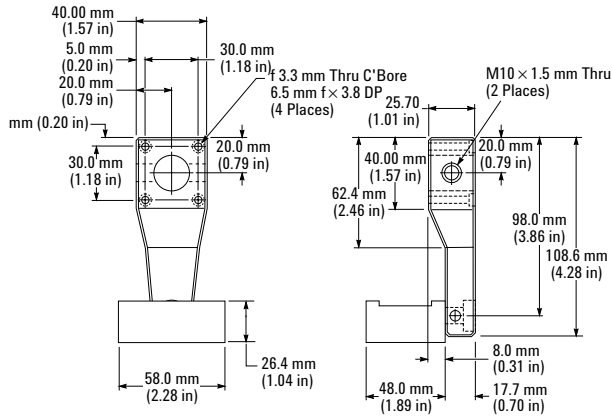

From Agilent 10768A/10769A Measurement Kit

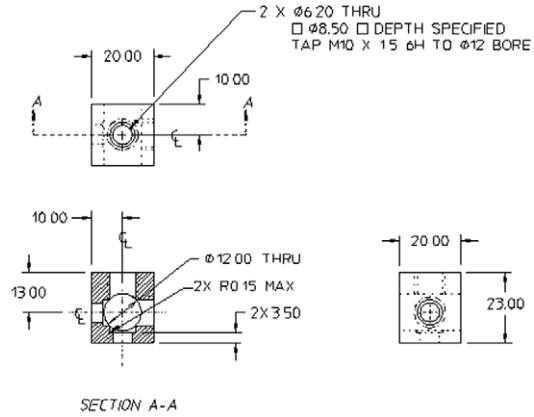

Agilent 10769B Turning Mirror (Base Block Only)

Agilent 55290A Angular Position Measurement Kit

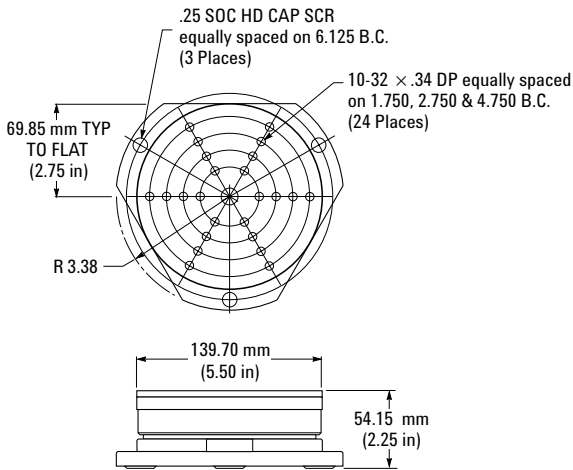

Rotary Indexing Table

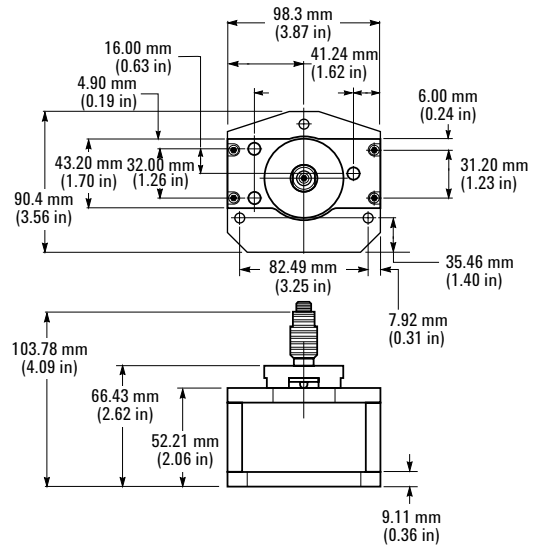

Fixture, Angle Position Measurement

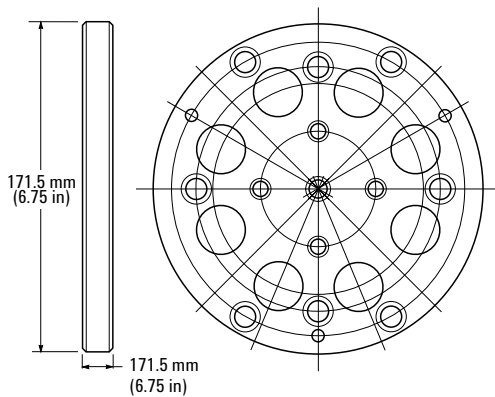

Adapter Plate

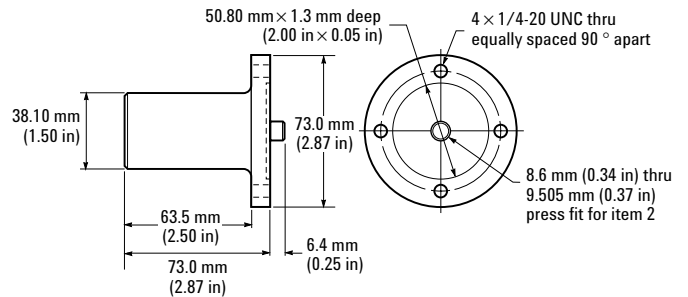

Flanged Shaft

Agilent Technologies' Test and Measurement Support, Services, and Assistance

Agilent Technologies aims to maximize the value you receive, while minimizing your risk and problems. We strive to ensure that you get the test and measurement capabilities you paid for and obtain the support you need. Our extensive support resources and services can help you choose the right Agilent products for your applications and apply them successfully. Every instrument and system we sell has a global warranty. Support is available for at least five years beyond the production life of the product. Two concepts underlie Agilent's overall support policy: "Our Promise" and "Your Advantage."

Our Promise

"Our Promise" means your Agilent test and measurement equipment will meet its advertised performance and functionality. When you are choosing new equipment, we will help you with product information, including realistic performance specifications and practical recommendations from experienced test engineers. When you use Agilent equipment, we can verify that it works properly, help with product operation, and provide basic measurement assistance for the use of specified capabilities, at no extra cost upon request. Many self-help tools are available.

Your Advantage

"Your Advantage" means that Agilent offers a wide range of additional expert test and measurement services, which you can purchase according to your unique technical and business needs. Solve problems efficiently and gain a competitive edge by contracting with us for calibration, extra-cost upgrades, out-of-warranty repairs, and on-site education and training, as well as design, system integration, project management, and other professional services. Experienced Agilent engineers and technicians worldwide can help you maximize your productivity, optimize the return on investment of your Agilent instruments and systems, and obtain dependable measurement accuracy for the life of those products.

By internet, phone, or fax, get assistance with all your test and measurement needs.

Online Assistance

www.agilent.com/find/assist

Phone or Fax

United States:

(tel) 1 800 452 4844

Canada:

(tel) 1 877 894 4414

(fax) (905) 282 6495

Europe:

(tel) (31 20) 547 2323

(fax) (31 20) 547 2390

Japan:

(tel) (81) 426 56 7832

(fax) (81) 426 56 7840

Latin America:

(tel) (305) 269 7500

(fax) (305) 269 7599

Australia:

(tel) 1 800 629 485

(fax) (61 3) 9210 5947

New Zealand:

(tel) 0 800 738 378

(fax) (64 4) 495 8950

Asia Pacific:

(tel) (852) 3197 7777

(fax) (852) 2506 9284

Product specifications and descriptions in this document subject to change without notice.

Copyright © 1997, 2001 Agilent Technologies

Printed in U.S.A. March 16, 2001

5964-9307E



Agilent Technologies

This datasheet has been download from:

www.datasheetcatalog.com

Datasheets for electronics components.