

SPECIFICATION

Device Name : ZTRAP

Type Name : ENE241D-20A

Spec. No. : MS5K2564

Date : Feb. 3. 1999

This material and the information herein is the property of Fuji Electric Co., Ltd. They shall be neither reproduced, copied, lent, or disclosed in any way whatsoever for the use of any third party nor used for the manufacturing purposes without the express written consent of Fuji Electric Co., Ltd.

Fuji Electric Co., Ltd.
Matsumoto Factory

	DATE	NAME	APPROVED	Fuji Electric Co., Ltd.		
DRAWN	Feb. 3 '99	K. Kobayashi	<i>[Signature]</i>	DWG. NO.	MS5K2564	1/6
CHECKED	Feb. 3 '99	K. Fujita	<i>[Signature]</i>			

Revised Records

Date	Classi- fication	Ind.	Content	Applied date	Drawn	Checked	Approved
Feb. - 3 - 1999	enactment	—	—	Issued date	—	<i>K. Fujieda</i>	<i>K. Fujieda</i>

This material and the information herein is the property of
 Fuji Electric Co., Ltd. They shall be neither reproduced, copied,
 lent, or disclosed in any way whatsoever for the use of any
 third party nor used for the manufacturing purposes without
 the express written consent of Fuji Electric Co., Ltd.

1. SCOPE

This specification provides the ratings and test requirements for FUJI Z-TRAP CERAMIC SURGE ABSORBER.

2. TYPE

ENE241D-20A

3. OUT VIEW

3.1. OUT VIEW, MARKING

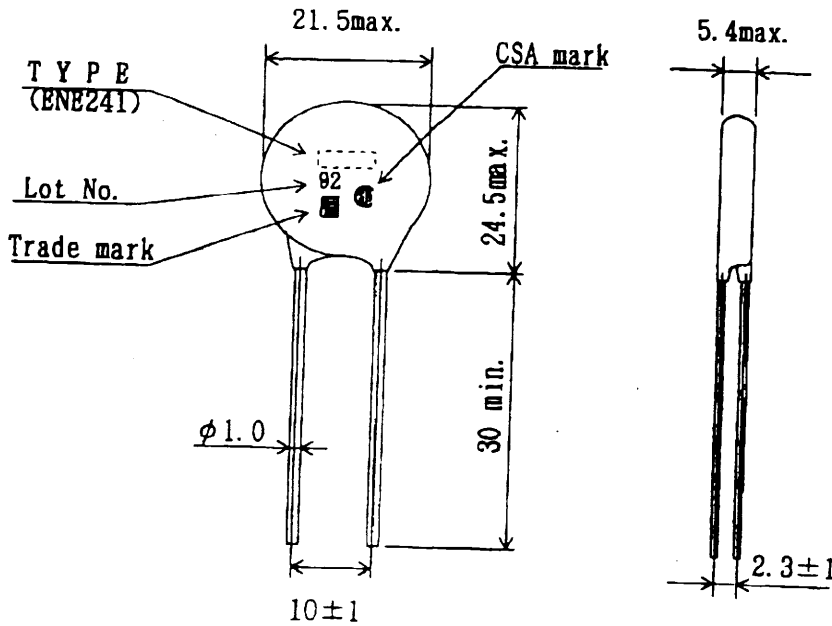

UL No.	File No.
UL1414	E66188
UL1449	E123894

CSA No	LR98228
--------	---------

[Dimensions: mm]

3.2. Explanation of lot No.

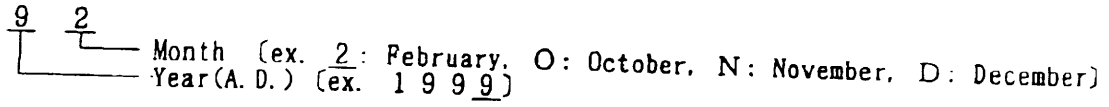

Fuji Electric Co., Ltd.

DWG. NO.

MS5K2564 3/6

H04-004-03

This material and the information herein is the property of Fuji Electric Co., Ltd. They shall be neither reproduced, copied, lent, or disclosed in any way whatsoever for the use of any third party nor used for the manufacturing purposes without the express written consent of Fuji Electric Co., Ltd.

4. RATINGS

4-1 MAXIMUM RATINGS

I T E M		SYMBOL	CONDITIONS	RATING	UNIT
Maximum allowable operating voltage	AC	VIN	50/60Hz	150	Vrms
	DC			200	V
Maximum allowable peak current		Ip	8/20 μ s, 2times Interval:5min.	7000	A
			8/20 μ s, 1time	10000	
Maximum allowable energy absorption		Wz	2ms. 1time	120	J
Allowable average power dissipation		P		1.0	W
Dielectric strength (Body to Lead)		Vds	1min. AC voltage 50/60Hz	1500	Vrms
Operating ambient temperature		Topg		- 40 ~ + 85	°C
Storage temperature		Tstg		- 40 ~ + 125	°C

4-2 ELECTRICAL CHARACTERISTICS

I T E M	SYMBOL	CONDITIONS	CHARACTERISTICS	UNIT
Varistor voltage	V1	I = 1 mA , DC	216 ~ 264	V
Clamping voltage	Vc	Ip =100A. 8/20 μ s	395 max	V
Typical capacitance	C	f = 1KHz	2600	pF
Varistor voltage temperature coefficient	Tc	25°C to 85°C	-0.05 max	%/°C

4-3 MECHANICAL CHARACTERISTICS

I T E M	CHARACTERISTICS	UNIT
Net weight	about 4.5	g
Vibration proof	50	m/s ²

Fuji Electric Co., Ltd.

DWG. NO.

MS 5 K 2 5 6 4 4/6

H04-004-03

This material and the information herein is the property of Fuji Electric Co., Ltd. They shall be neither reproduced, copied, lent, or disclosed in any way whatsoever for the use of any third party nor used for the manufacturing purposes without the express written consent of Fuji Electric Co., Ltd.

5. TEST AND INSPECTION

5.1 NORMAL TEST AMBIENT

All tests and measurements shall be conducted basically at an ambient temperature of $25 \pm 2^\circ\text{C}$, R.H.65%, but these will be allowed to conduct at ambient temperature of $25 \pm 5^\circ\text{C}$ and other condition mentioned above when doubt is for nothing in judgement.

5.2 INSPECTION

Inspected with eye and measure. Satisfactory for item 3.

5.3 TEST

5.3.1 VARISTOR VOLTAGE TEST

Indicates the varistor terminal voltage measured with a 1mA DC applied. (Fig. 1)
Satisfactory for item 4.2.

5.3.2 CLAMPING VOLTAGE TEST

Indicates the peak terminal voltage measured with an $8/20\mu\text{s}$ impulse current at 100A. (Fig. 2) Satisfactory for item 4.2.

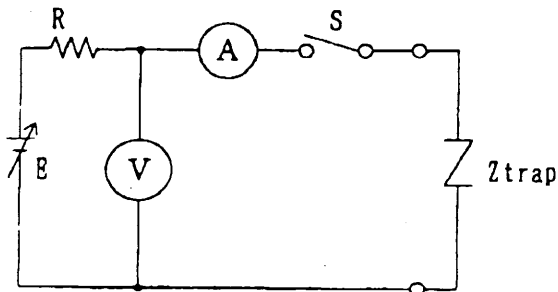

E : dc voltage source
R : protective resistance
S : switch
A : dc ammeter
V : dc voltmeter

Fig. 1 Circuit for varistor voltage test

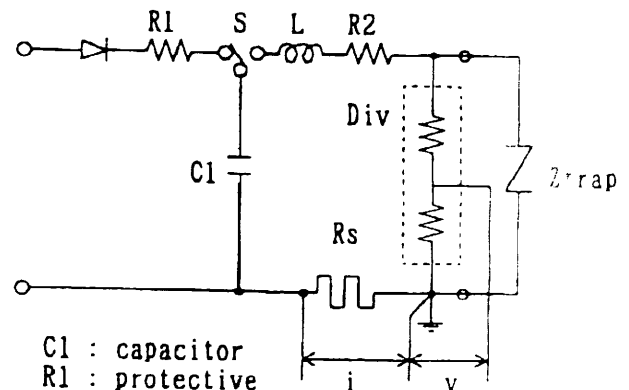

C1 : capacitor
R1 : protective resistance for charge
S : switch
L : reactor
R2 : resistance
Rs : current resistance
Div : voltage divider

Fig. 2 Circuit for clamping voltage test

This material and the information herein is the property of Fuji Electric Co., Ltd. They shall be neither reproduced, copied, lent, or disclosed in any way whatsoever for the use of any third party nor used for the manufacturing purposes without the express written consent of Fuji Electric Co., Ltd.

6. RELIABILITY TEST

No	ITEM	TEST CONDITIONS	REQUIREMENT
1	Temperature cycling	5cycles, -40°C(30min.)→R.T.(15min.)→+85°C(30min.)→R.T.(15min.)	$\Delta V1/V1 \leq \pm 10\%$
2	Heat shock	5cycles, +100°C(5min.) → 0°C(5min.) → +100°C(5min.)	$\Delta V1/V1 \leq \pm 5\%$
3	Resistance to soldering heat	Soldering temperature : 260 ±5°C Dipped time : 10±1sec Dipped point : 4±0.8mm from the end of unit.	$\Delta V1/V1 \leq \pm 5\%$
4	Solderability	Soldering temperature : 230 ±5°C Dipped time : 5 ±1sec	Over 95% surface should be covered with new solder
5	Humidity	Ambient condition : 40°C, 90 to 95% 1000H	$\Delta V1/V1 \leq \pm 10\%$
6	High temperature operating	Ambient temperature : 85°C Maximum AC&DC applied voltage for 1000H.	$\Delta V1/V1 \leq \pm 10\%$
7	Storage	Ambient temperature : 125°C for 1000H. Ambient temperature : -40°C for 1000H.	$\Delta V1/V1 \leq \pm 10\%$
8	Falling	Fall 75cm high to the oak that is over 30mm in thickness. 3times.	No out standing damage
9	Vibration	Double amplitude : 1.5mm Vibration frequency cycles : 10→55→10Hz /1min. In each of three mutually perpendicular direction for 2 hours.	No out standing damage
10	Terminal bending strength	Keep the unit in the vertical direction and the weight specified below applied to the end of the terminal. The unit shall be bent gradually by 90°, then 180° in the opposite direction and again back to the original position. φ 0.6, φ 0.8: 4.9N (0.5kgf) φ 1.0: 9.8N (1.0kgf) (Terminal diameter: Load)	No outstanding damage.
11	Terminal pull strength	Fix the unit and then the load specified below applied gradually in the axial direction and keeping for 5 sec. φ 0.6, φ 0.8: 9.8N (1.0kgf) φ 1.0: 24.5N (2.5kgf) (Terminal diameter: Load)	No outstanding damage.

V 1 : Variator voltage

Fuji Electric Co., Ltd

DWG. NO.

MS 5 K 2 5 6 4 6/6

This material and the information herein is the property of Fuji Electric Co., Ltd. They shall be neither reproduced, copied, lent, or disclosed in any way whatsoever for the use of any third party not used for the manufacturing purposes without the express written consent of Fuji Electric Co., Ltd.