PF0147

MOS FET Power Amplifier Module for GSM Handy Phone

HITACHI

ADE-208-322D (Z)
5th. Edition
June, 1996

Application

For GSM class4 890 to 915MHz.

Features

- 2stage amplifier
- Small package: 0.6cc
- High efficiency: 40% Typ
- High speed switching: 0.9 μ sec Typ

Pin Arrangement

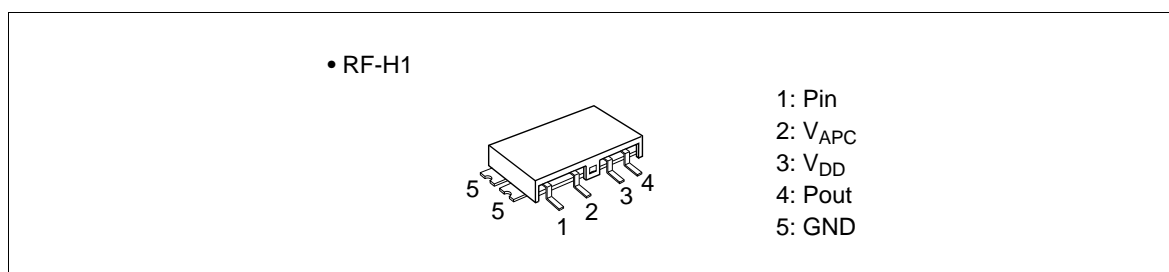

Absolute Maximum Ratings (T_c = 25°C)

Item	Symbol	Rating	Unit
Supply voltage	VDD	10	V
Supply current	IDD	3	A
VAPC voltage	VAPC	6	V
Input power	Pin	20	mW
Operating case temperature	T _c (op)	-30 to +100	°C
Storage temperature	T _{stg}	-30 to +100	°C
Output power	P _{out}	7	W

PF0147

Internal Diagram

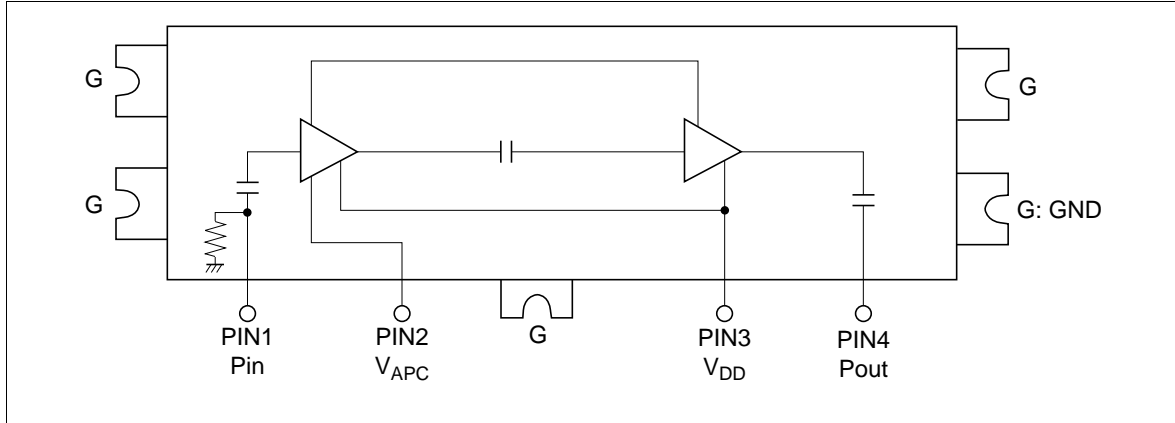

Electrical Characteristics (Tc = 25°C)

Item	Symbol	Min	Typ	Max	Unit	Test Condition
Frequency range	f	890	—	915	MHz	
Control voltage range	VAPC	0.5	—	3.5	V	
Drain cutoff current	IDS	—	—	100	μA	VDD = 10V, VAPC = 0V
Total efficiency	ηT	35	40	—	%	Pin = 10mW, VDD = 4.8V,
2nd harmonic distortion	2nd H.D.	—	-50	-40	dBc	Pout = 3.2W (at APC controlled),
3rd harmonic distortion	3rd H.D.	—	-50	-40	dBc	RL = Rg = 50Ω, Tc = 25°C
Input VSWR	VSWR (in)	—	2	3	—	
Output power (1)	Pout (1)	3.2	3.8	—	W	Pin = 10mW, VDD = 4.8V, VAPC = 3.5V, RL = Rg = 50Ω, Tc = 25°C
Output power (2)	Pout (2)	1.8	2.4	—	W	Pin = 10mW, VDD = 4.3V, VAPC = 3.5V, RL = Rg = 50Ω, Tc = 80°C
Isolation	—	—	—	-20	dBm	Pin = 10mW, VDD = 4.8V, VAPC = 0.5V, RL = Rg = 50Ω, Tc = 25°C
Switching time	tr, tf	—	0.9	2	μs	Pin = 10mW, VDD = 4.8V, Pout = 3.2W, RL = Rg = 50Ω, Tc = 25°C
Stability	—	No parasitic oscillation			—	Pin = 10mW, VDD = 6.0V, Pout ≤ 3.2W (at APC controlled), Rg = 50Ω, t = 20sec., Tc = 25°C, Output VSWR = 10 : 1 All phases

Test System Diagram

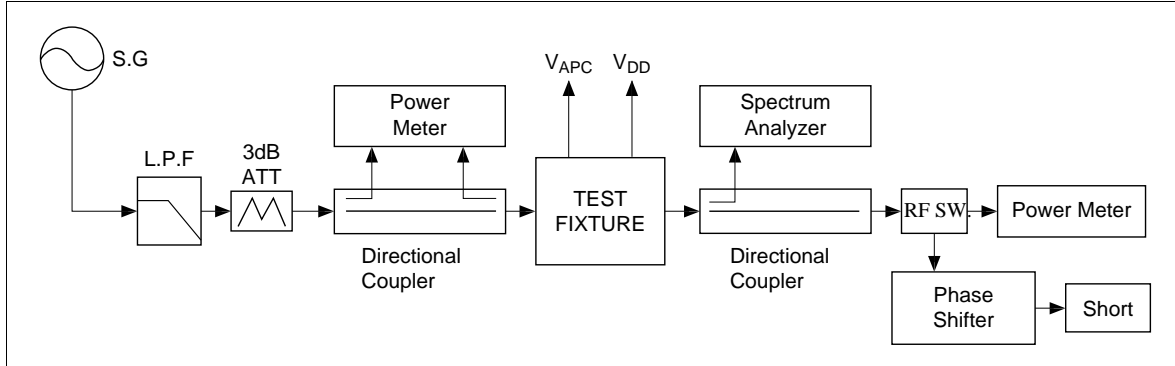

Switching Time Test Diagram

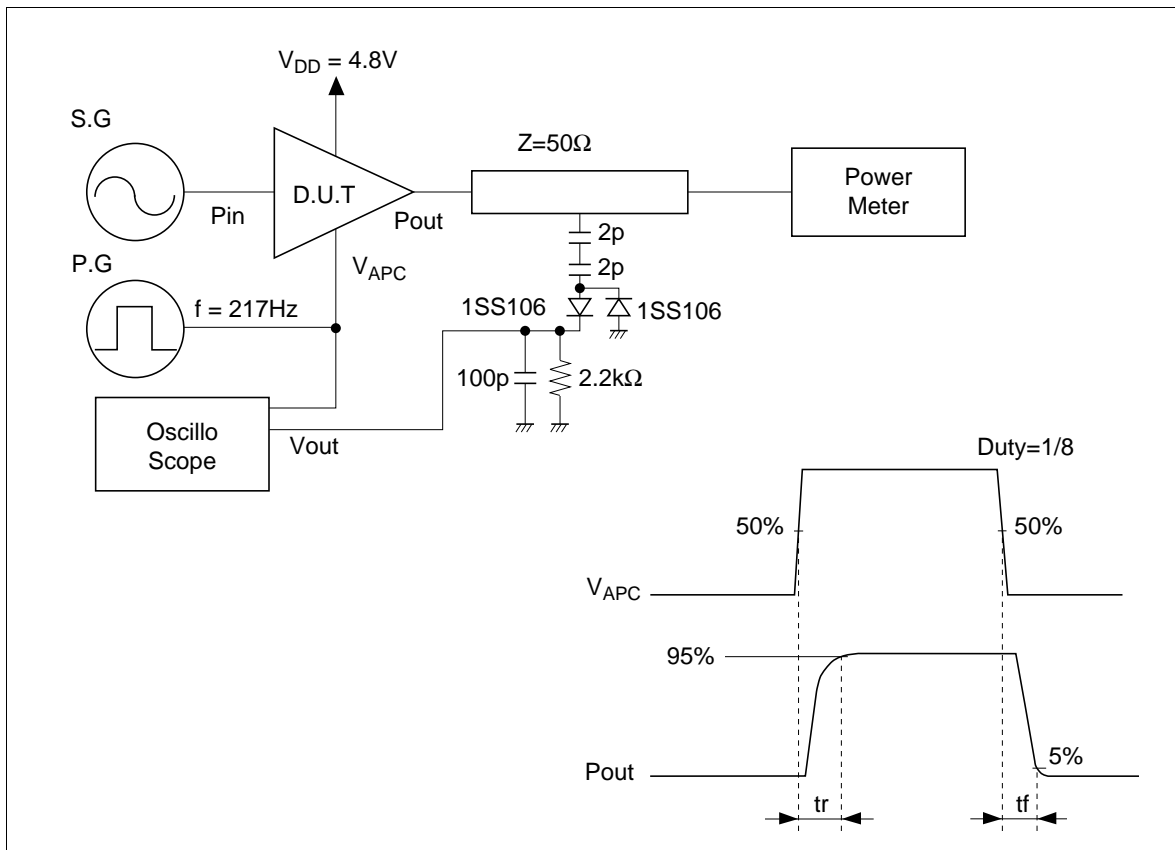

PF0147

Test Fixture

Test Circuit

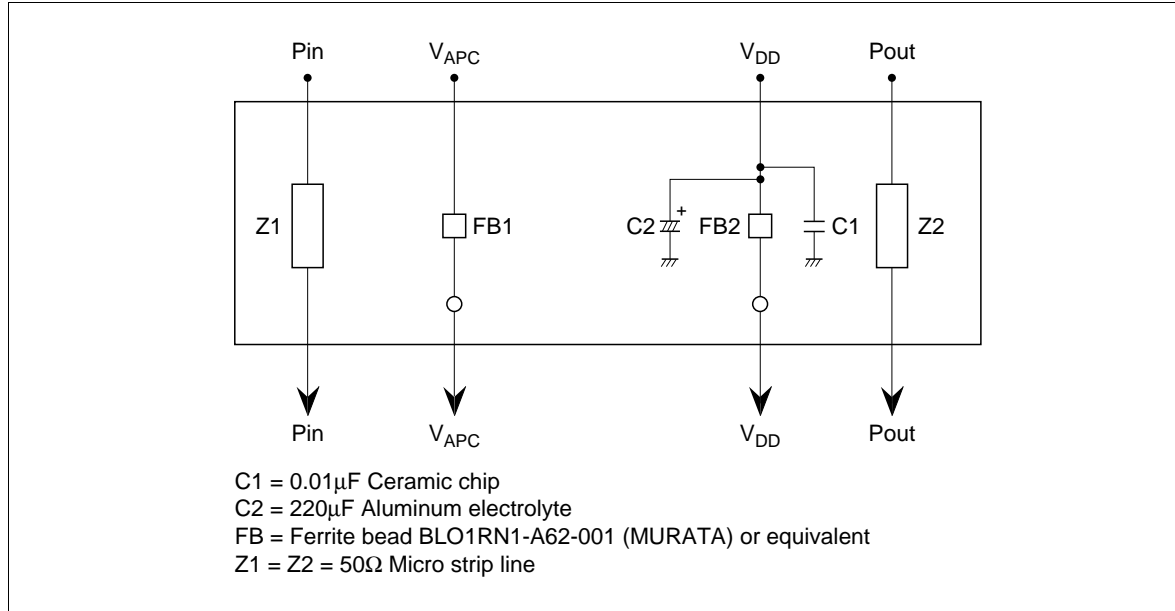

Printed Circuit Board Layout

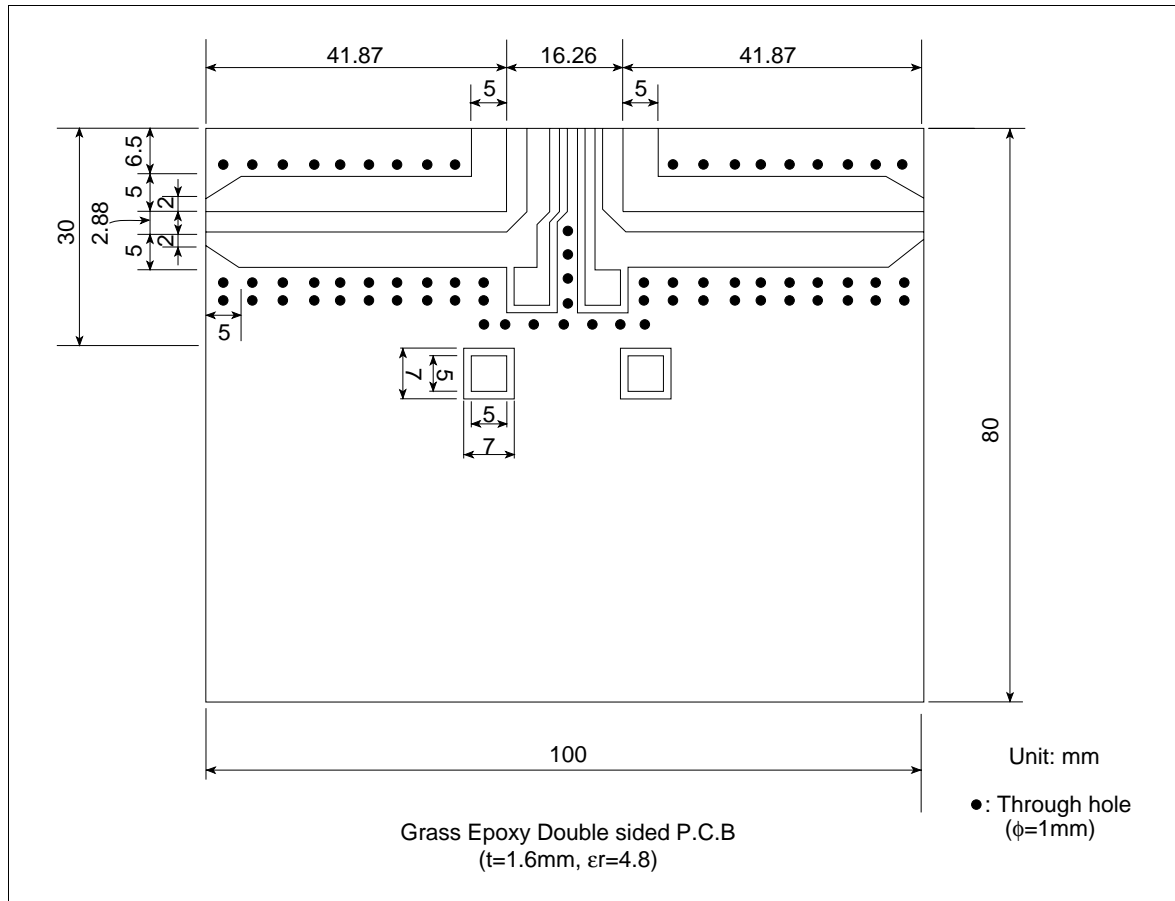

Note for Use

- At evaluation of a sample, take the drop of VDD voltage and power loss on test P.C.B. into account.
- Apply control voltage range as $V_{APC} = 0.5$ to $3.5V$, and GSM burst mode must be applied to all operation. For instance, pulse width = $0.577msec.$, duty = 12.5% and $V_{APC} \leq 0.5V$, for all $4.616msec.$ frame except for $0.577msec.$ pulse.
- Unevenness and distortion at the surface of PCB mounted module should be as small as possible.
- To protect devices from electro-static damage, soldering iron, measuring equipment and human body, etc. should be grounded.
- To avoid the degradation of efficiency and output power, lead pins should not be floated from copper foil of PCB, and connected to right position of RF signal line. (refer to figure 2)
- Recommendation to improve the thermal resistance is shown below.
 - Make through holes as many as possible under module.
 - Use heat sink on the top case of module.
- When the external components (Isolator, Duplexer, etc.) of the module are changed, the electrical characteristics of total system should be evaluated enough.
- To avoid destruction of module caused by excess power consumption, voltage of APC should be limited less than $6V$.
- To get good stability, all GND pins should be soldered to ground pattern of PCB.
- Don't apply Full Heating Methods except Infrared Heating Methods.
- In case of Partial Heating Methods, soldering temperature and time should be less than $230^{\circ}C$, $10sec.$, per each GND pin.
- Soldering temperature and time for I.R. Reflow should be the reflow profile shown in figure 2.
- Recommended conditions for Rising Methods shows as follows.
 - Solvents: de-ionized water, isopropyl alcohol, ethyl alcohol
 - Rising condition: in case of soak rising 5 Min Max, in case of ultrasonic rising 5 Min Max
- Don't apply dipping solder method to mount.
- Apply the way of washing after actual confirmation.
- Recommended pattern of footprint is shown in figure 3.

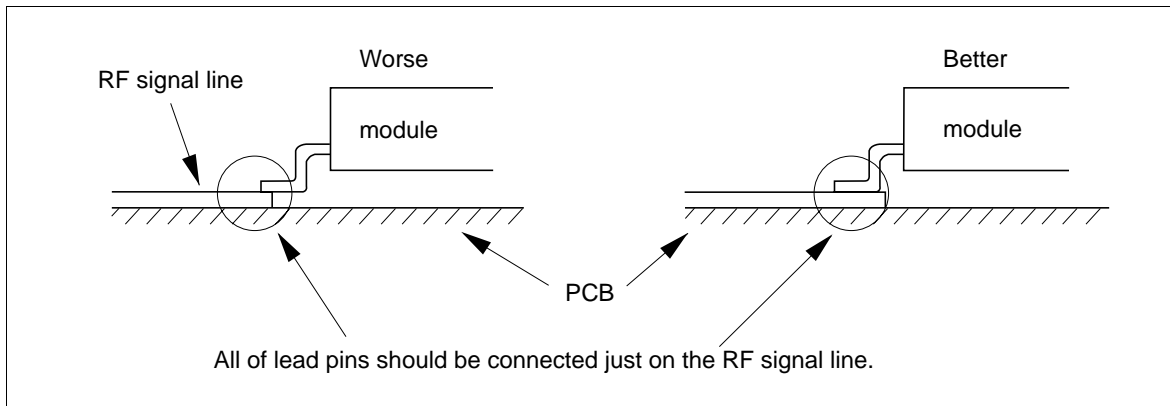

Figure 1

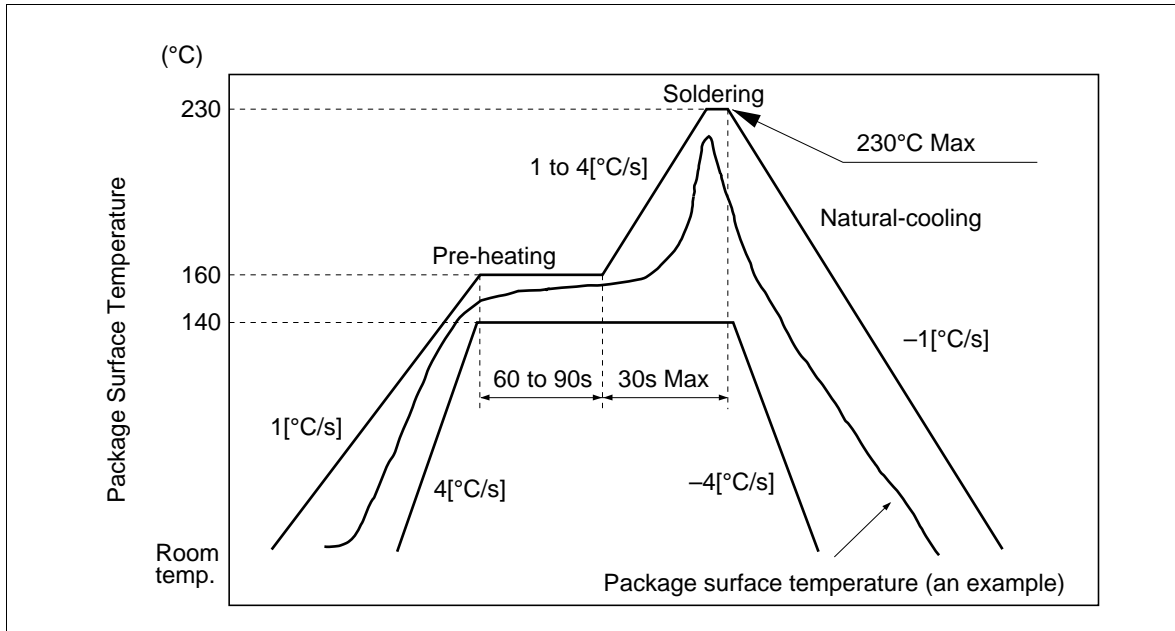

Figure 2 Recommended Reflow Profile

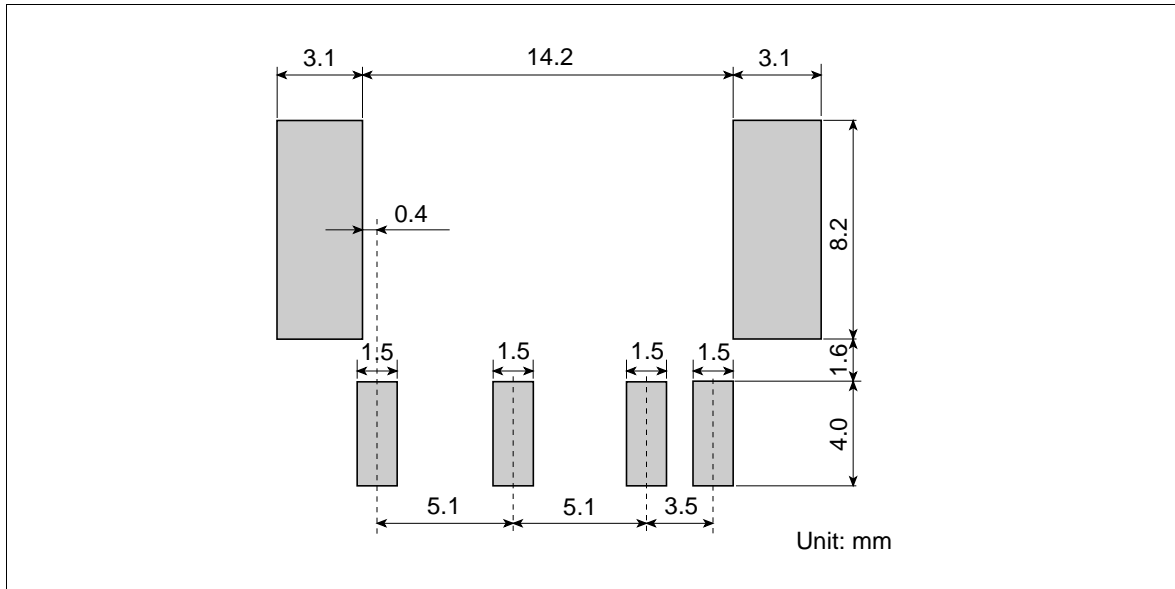
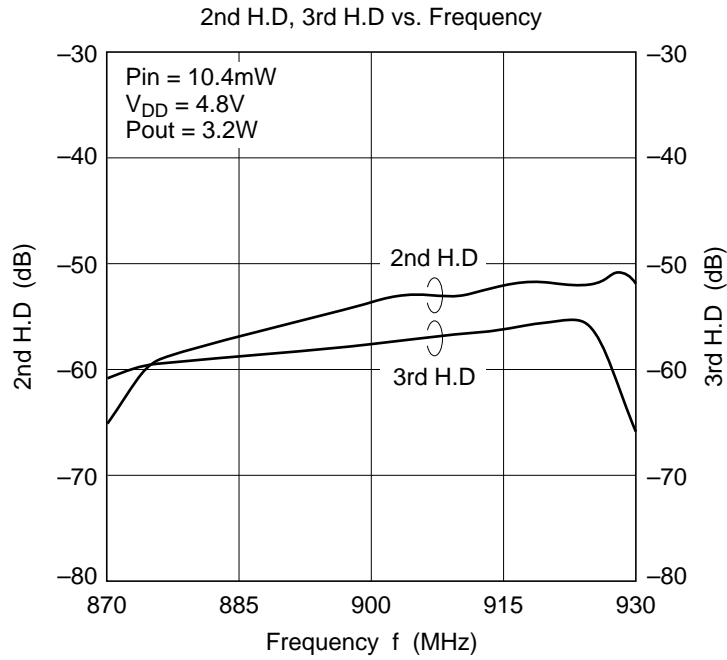
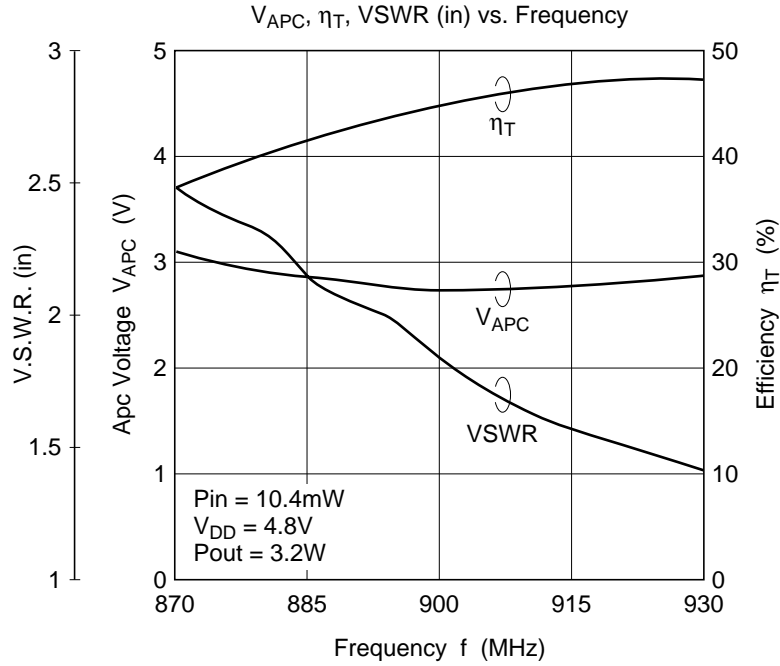
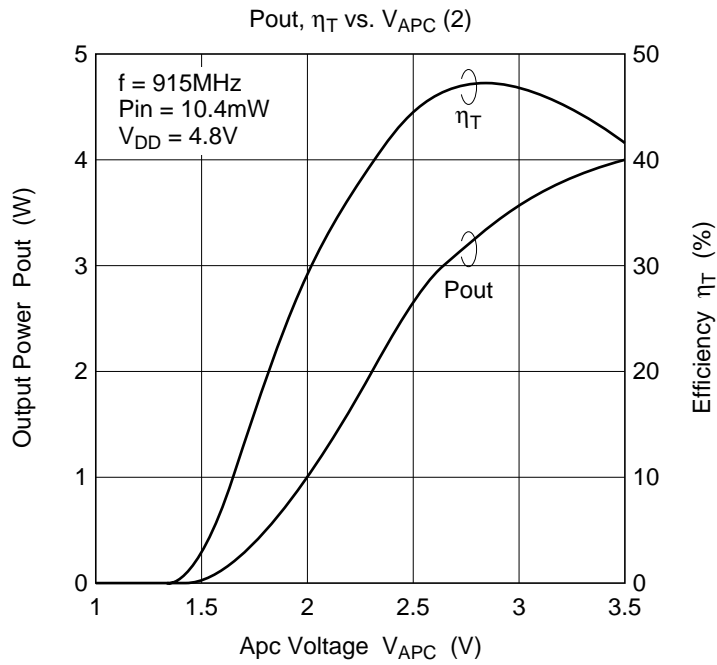
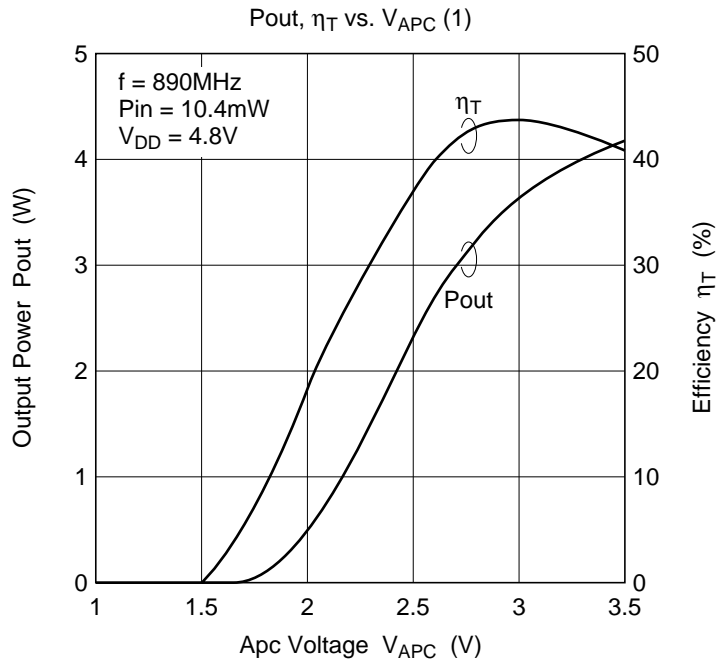
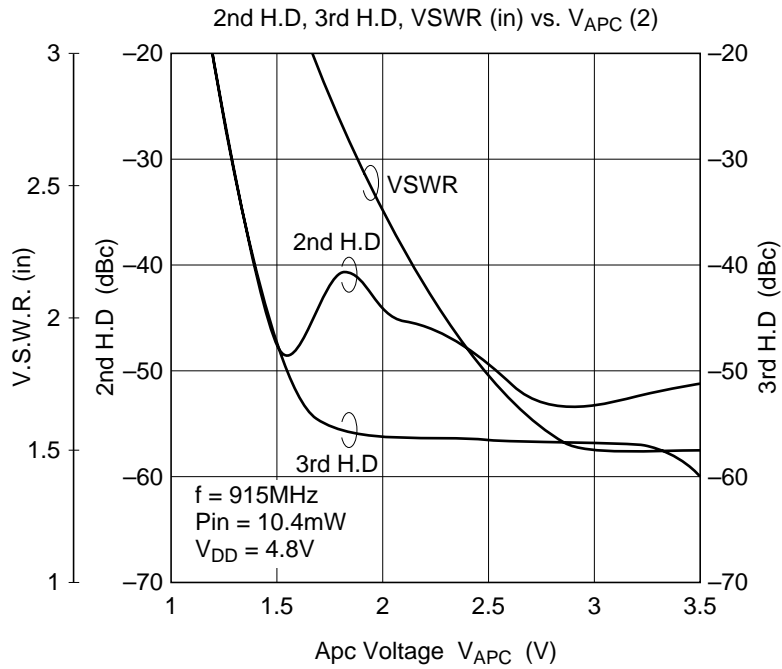
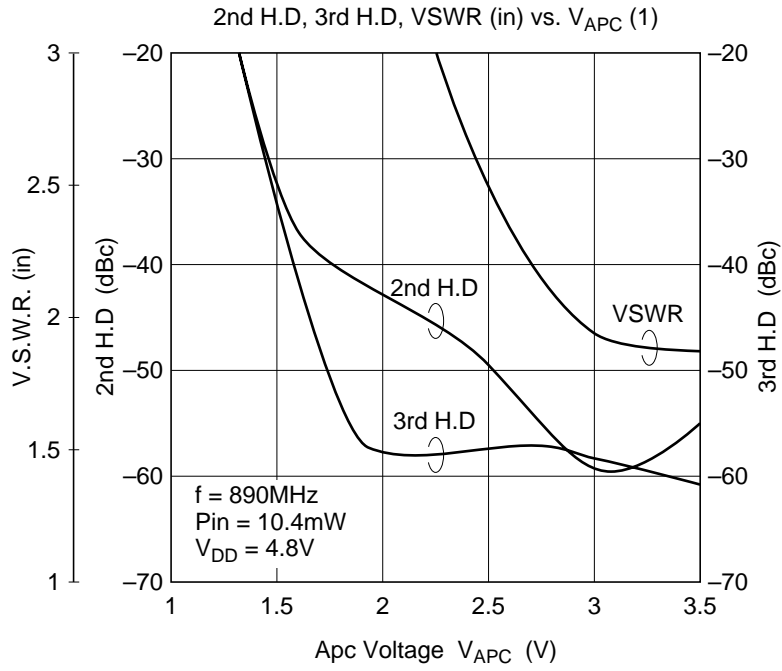

Figure 3 Recommended Pattern of Footprint

Characteristics Curve







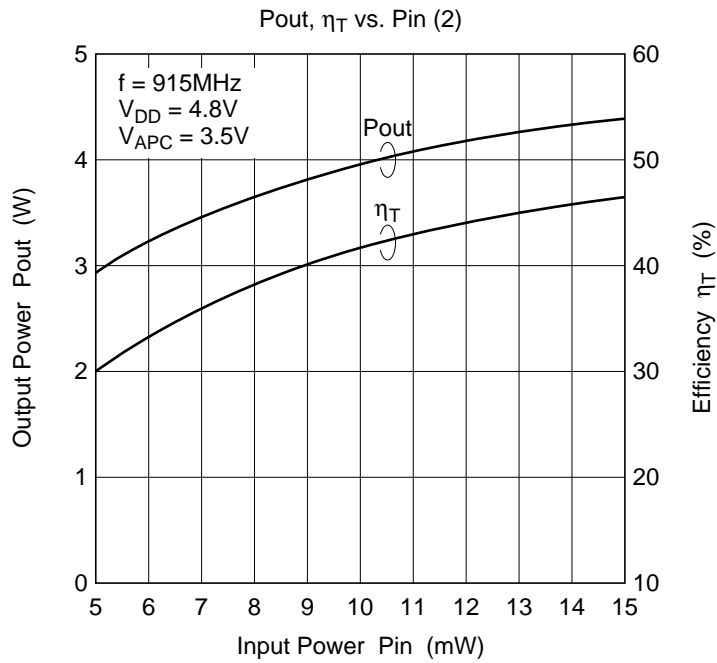
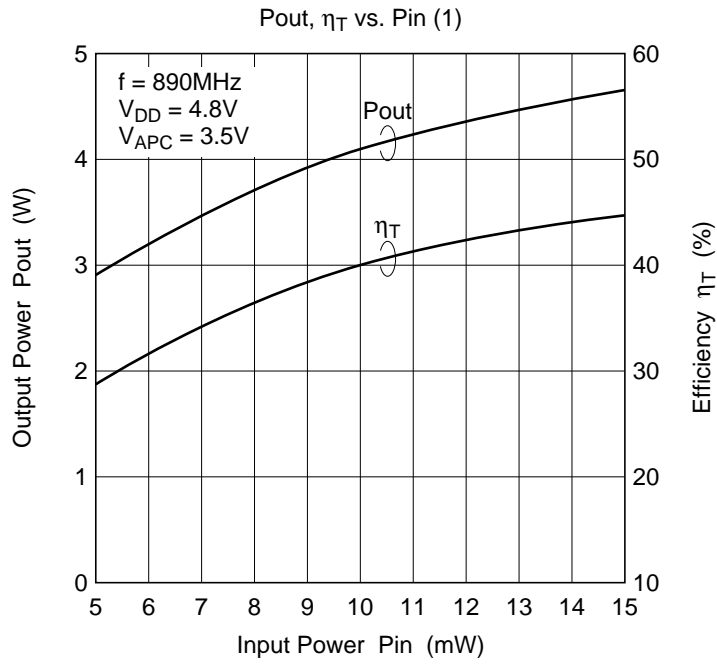

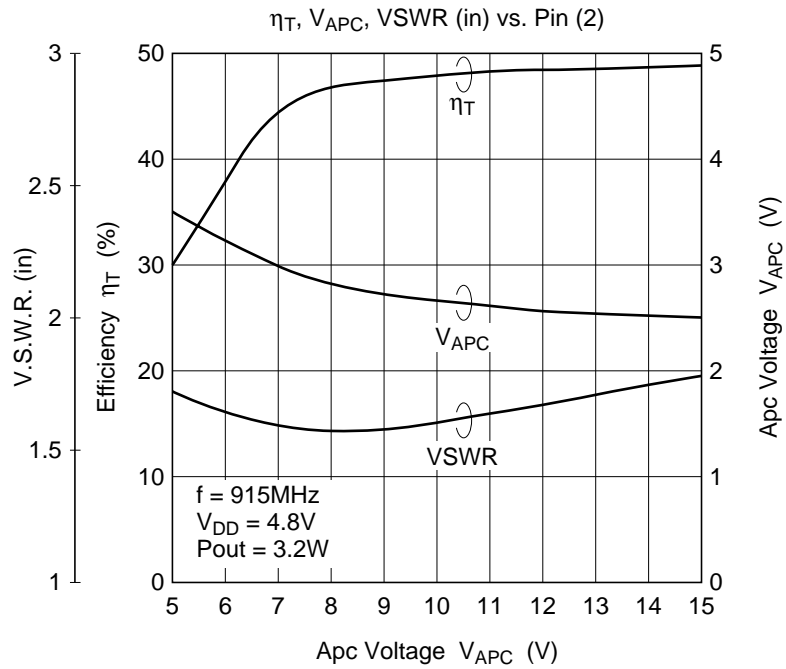
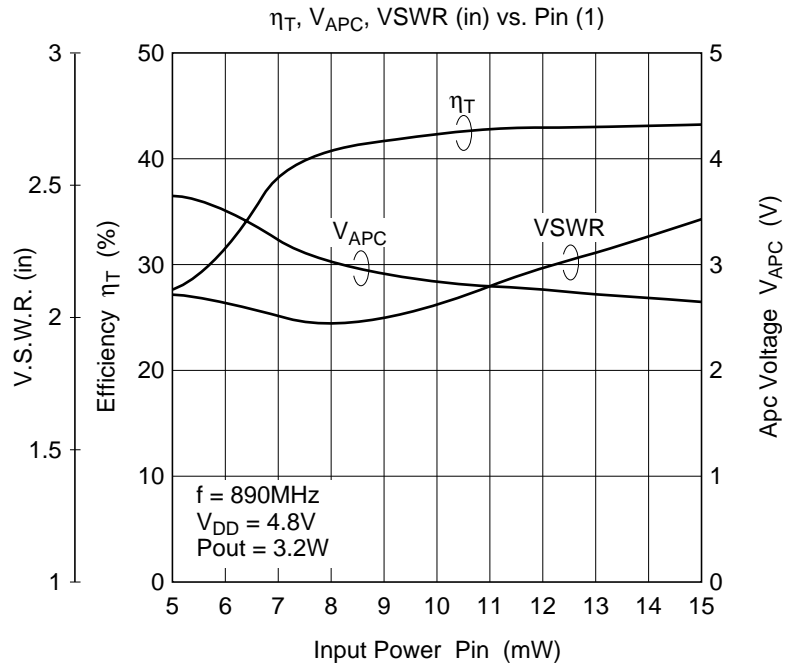

PF0147

Package Dimensions

Unit: mm

