

### TEST AND MEASUREMENT PRODUCTS

#### Description

The Edge818 is an octal pin electronics driver and window comparator fabricated in a wide voltage CMOS process. It is designed specifically for Test During Burn In (TDBI) applications, where cost, functional density, and power are all at a premium.

The Edge818 incorporates eight channels of programmable drivers and window comparators into one 14 mm X 20 mm 100 pin MQFP package. Each channel has per pin driver levels, data, and high impedance control. In addition, each comparator has per pin high and low threshold levels.

The Edge818 uses "Flex In" and "Flex Out" digital inputs, and can therefore mate directly with any digital technology providing a minimum 2V swing. The digital outputs can mate directly with any digital technology.

The 18V driver output and receiver input range allow the Edge818 to interface directly with TTL, ECL, CMOS (3V, 5V, and 7V), LVCMOS, and custom level circuitry, as well as the high voltage (Super Voltage) level required for many special test modes for Flash Devices.

#### Features

- 18V I/O Range
- 50 MHz Operation
- Per Pin Flexibility
- Programmable Input Thresholds
- Flex In Digital Inputs
- Flex Out Digital Outputs
- Small footprint (100 pin MQFP)

#### Applications

- Burn In ATE
- Low Cost ATE
- Instrumentation

#### Functional Block Diagram

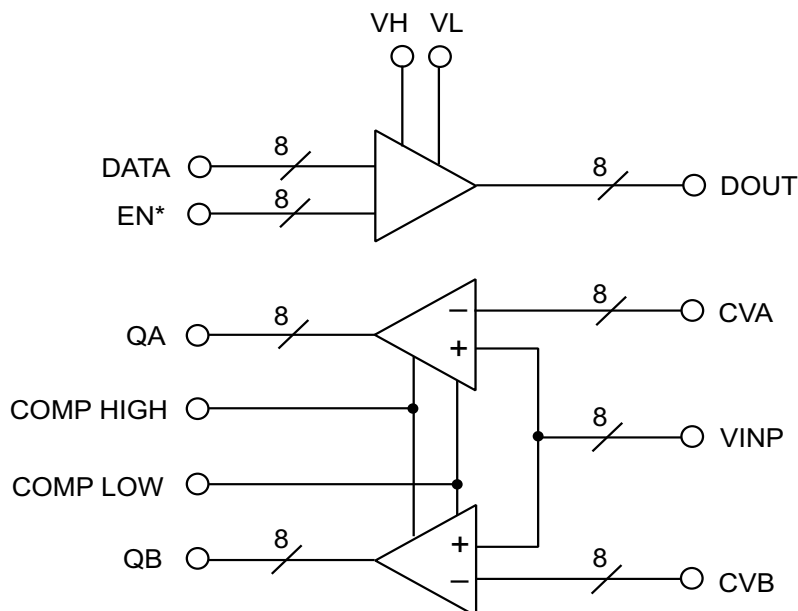

**TEST AND MEASUREMENT PRODUCTS**
**PIN Description**

Pin Name	Pin Number	Description
DATA (0:7)	100, 4, 8, 12, 19, 23, 27, 31	Digital inputs which determine the high/low state of the driver, when it is enabled.
EN* (0:7)	3, 7, 11, 15, 16, 20, 24, 28	Digital inputs which enable/disable the driver.
QA (0:7) QB (0:7)	1, 5, 9, 13, 18, 22, 26, 30 2, 6, 10, 14, 17, 21, 25, 29	Comparator digital outputs.
DOUT (0:7)	79, 75, 71, 67, 64, 60, 56, 52	Driver Outputs.
VINP (0:7)	81, 77, 73, 69, 62, 58, 54, 50	Comparator Inputs.
VH (0:7)	80, 76, 72, 68, 63, 59, 55, 51	Unbuffered analog inputs that set the driver "high" voltage level.
VL (0:7)	78, 74, 70, 66, 65, 61, 57, 53	Unbuffered analog inputs that set the driver "low" voltage level.
CVA (0:7)	97, 95, 89, 87, 44, 42, 36, 34	Analog inputs that set the threshold for the A comparators.
CVB (0:7)	96, 94, 88, 86, 45, 43, 37, 35	Analog inputs that set the threshold for the B comparators.
VBB	46, 85	Analog input voltage that sets the threshold for the digital inputs.
COMP HIGH	33, 98	Unbuffered analog input that sets the high level of the comparator outputs.
COMP LOW	32, 99	Unbuffered analog input that sets the low level of the comparator outputs.
VCC	40, 41, 47, 49, 82, 84, 90, 91	Positive power supply.
VEE	38, 39, 48, 83, 92, 93	Negative power supply.

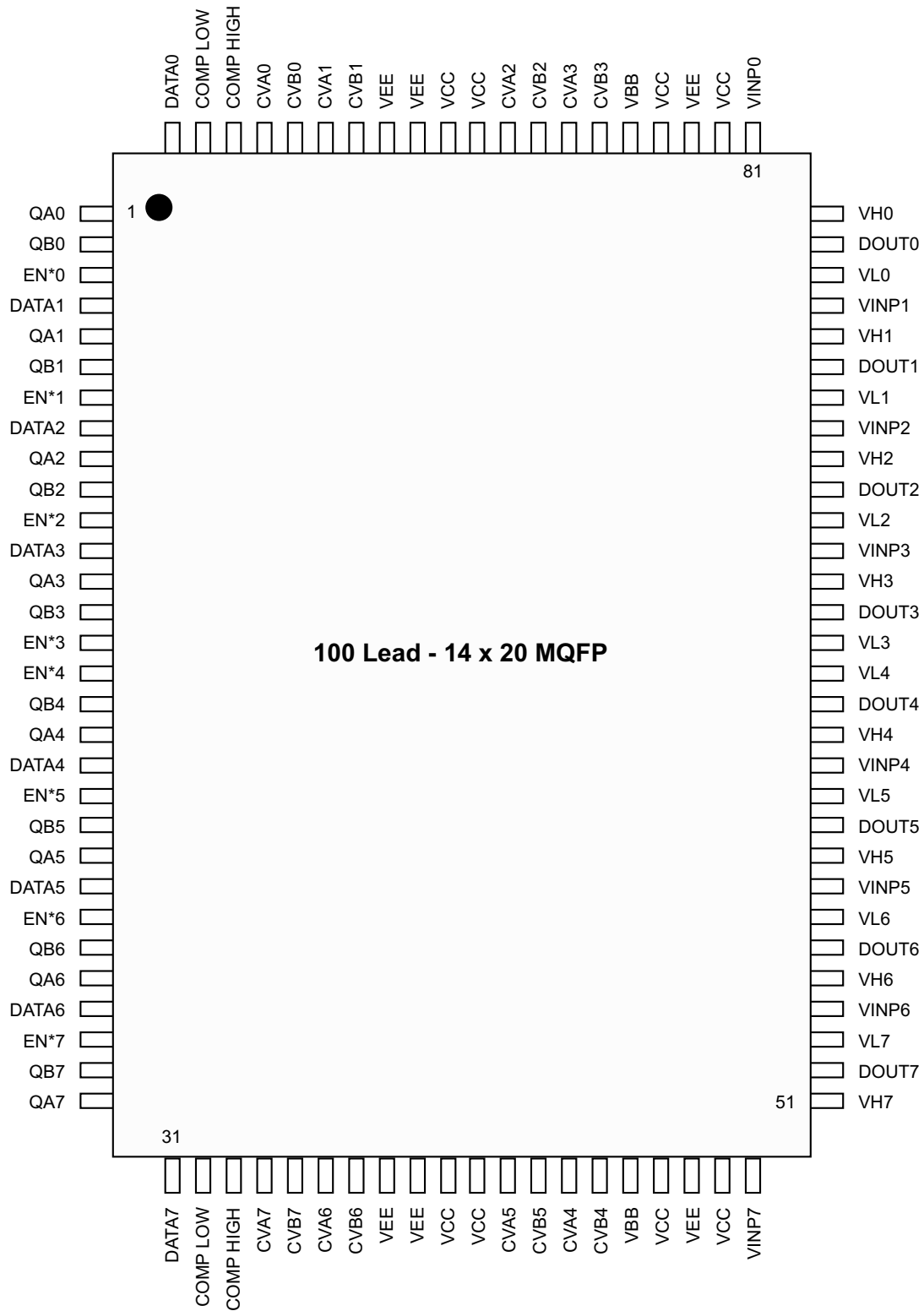
**TEST AND MEASUREMENT PRODUCTS**
**PIN Description (continued)**

## TEST AND MEASUREMENT PRODUCTS

### Circuit Description

#### Driver Description

The Edge818 supports programmable high and low levels and tristate per channel. There are no shared lines between any drivers. The EN\* and DATA signals are wide voltage high impedance analog inputs capable of receiving digital signals over a wide common mode range. VBB is the high impedance analog input which sets the threshold for EN\* and DATA.

<u>EN*, DATA</u>	<u>Status</u>
> VBB	"1"
< VBB	"0"

With EN\* high, the driver goes into a high impedance state. With EN\* low, DATA high forces the driver into a high state, and DATA low forces the driver into a low state.

<u>EN*</u>	<u>DATA</u>	<u>DOUT</u>
1	X	HiZ
0	1	VH
0	0	VL

#### Drive High and Low

VH and VL define the logical "1" and "0" levels of the driver, and can be adjusted anywhere over the range determined by VCC and VEE. There are no restrictions between VH and VL, other than they must remain within the power supply levels.

$$\begin{aligned} VEE &\leq VH \leq VCC \\ VEE &\leq VL \leq VCC \end{aligned}$$

The VH and VL inputs are unbuffered in that they also provide the driver output current (see Figure 3), so the source of VH and VL must have ample current drive capability.

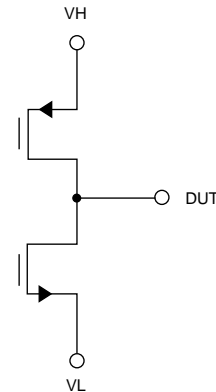

**Figure 3. Simplified Model of the Unbuffered Output Stage**

#### Driver Output Protection

In a functional testing environment, where a resistor is added in series with the driver output to create a 50Ω driver, the Edge818 can withstand a short to any legal voltage for an indefinite amount of time.

In a low impedance application, with no additional output resistance, the system should be designed to check for a short circuit prior to connecting the driver, and tristate the driver if a short is detected.

#### Receiver Description

The Edge818 supports a window comparator with independent threshold levels per channel. There are no shared comparator lines between channels. CVA and CVB are high impedance analog voltage inputs which define the threshold voltages for comparators A and B.

If VINP is more positive than CVA or CVB, QA and QB will be high. Otherwise, QA and QB will be low.

<u>VINP</u>	<u>QA</u>
VINP > CVA	COMP HIGH
VINP < CVA	COMP LOW

<u>VINP</u>	<u>QB</u>
VINP > CVB	COMP HIGH
VINP < CVB	COMP LOW

**TEST AND MEASUREMENT PRODUCTS**
**Circuit Description (*continued*)**

The comparator outputs are "Flex Out". They are technology independent and may be adjusted over a wide voltage common mode range. COMP HIGH and COMP LOW are analog inputs which set the digital high and low levels (respectively) of QA and QB. COMP HIGH and COMP LOW are unbuffered inputs that provide the necessary drive current, so the sources for these levels must have adequate current capability.

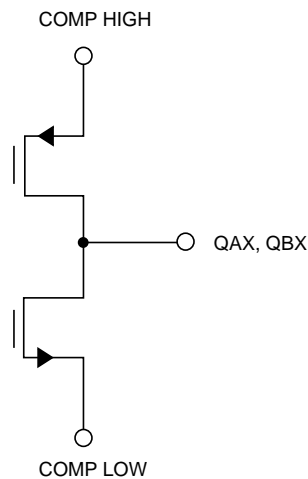

**Figure 4. Simplified Model of the Unbuffered Comparator Output Stage**

Typically, COMP HIGH and COMP LOW will be connected to the digital power supplies of the chip receiving QA and QB.

**Receiver Headroom**

There is ~3V of headroom required between the comparator thresholds and both power supply levels.

$$VEE + 3.0 \leq CVA, CVB \leq VCC - 3.0$$

#### Power Supply Decoupling

VCC and VEE should be decoupled to GND with a .1  $\mu$ F chip capacitor in parallel with a .001  $\mu$ F chip capacitor. A VCC and VEE plane, or at least a solid power bus, is recommended for optimal performance.

#### VH and VL Decoupling

As the VH and VL inputs are unbuffered and supply the driver output current, which can be quite large during edge transitions, decoupling capacitors for these inputs are recommended in proportion to the amount of output current requirements.

For applications where VH and VL are shared over multiple channels, a solid power plane to distribute these levels is preferred.

#### VBB

The two VBB pins are connected together on-chip. Therefore, only one VBB needs to be connected to for proper 818 operation.

The two pins may be used to daisy chain a VBB signal across a PC Board without having to route the actual signal underneath the 818.

#### Power Supplies

The Edge818 has several power supply requirements to protect the part in power supply fault situations, as well as during power up and power down sequences.

The following power supply requirements must be satisfied at all times:

$$VEE \leq \text{All I/O pins} \leq VCC \text{ at all times.}$$

The power sequence below can be used as a guideline when operating the Edge818:

<u>Power-on Sequencing</u>	<u>Power-off Sequencing</u>
1. VCC (substrate)	1. I/O Pins
2. VEE	2. VEE
3. I/O Pins	3. VCC

The three diode configuration shown in Figure 5 should be used on a once-per-board basis.

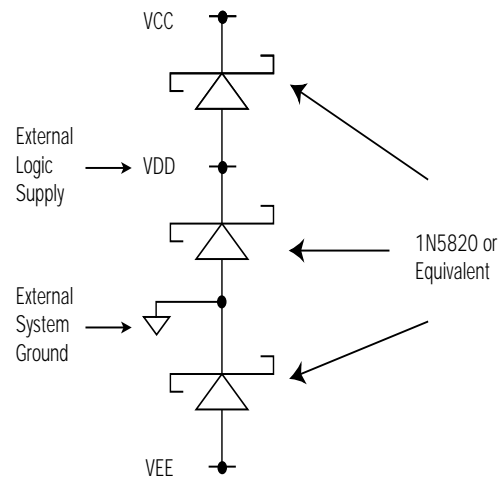

**Figure 5.**  
**Power Supply Protection Scheme**

**Warning:** It is extremely important that the voltage on any device pin does not exceed the range of VEE -0.5V to VCC +0.5V at any time, either during power up, normal operation, or during power down. Failure to adhere to this requirement could result in latchup of the device, which could be destructive if the system power supplies are capable of supplying large amounts of current. Even if the device is not immediately destroyed, the cumulative damage caused by the stress of repeated latchup may affect device reliability.

#### Power Dissipation/Thermal Considerations

The Edge818 is specified to operate with a die junction temperature,  $T_j$ , of up to 125 °C. The theoretical junction temperature is calculated as follows:

$$T_j = T_c + \theta_{jc} \times P_{total}$$

- Where  $T_j$  = The Theoretical Junction Temperature of the Edge818 [°C]  
 $T_c$  = The Case Temperature of the Edge818 [°C]  
 $\theta_{jc}$  = The Thermal Impedance of the Edge818 (junction to top center of case) [°C]  
 $P_{total}$  = The Total Power Dissipation of the Edge818 [W]

In order to maximize the reliability and operating lifetime of the Edge818, the junction temperature of the device should be minimized. It can be seen from the equation above that the junction temperature of the Edge818 is both a function of its case temperature and the total power dissipation of the device. Therefore, one can minimize the junction temperature of the Edge818 by minimizing the case temperature and the overall power dissipation of the device.

The case temperature of the Edge818 can be controlled through the use of some source of external cooling to regulate the case temperature (i.e. forced air). A heat sink can also be attached to the Edge818 in order to maximize the efficiency and increase the overall heat capacity of the external cooling used in an application.

A heat sink can be attached to the top of the device, and/or additional cooling can be attained through the bottom of the device (i.e. into a copper plane on the PCB or a heat sink attached to the device through a hole in the PCB). This will significantly decrease the effective thermal resistance between the case of the Edge818 and the cooling mechanism being used.

The total power dissipation of the Edge818 can also be minimized, but is ultimately dependent upon the requirements of the application. One way to attain a

relatively large power savings when using the device is to minimize the power supply levels that are used for a particular application. (Note that varying power supply levels may have an effect on device propagation delays and driver output impedance.) For illustrative purposes, this approach to power savings is evaluated on the following application:

Example:

The Edge818 is used to generate 3.3V output swings on all 8-channels simultaneously under the following conditions:

- $V_L = 0V$
- $V_H = 3.3V$
- $f = 25\text{ MHz}$
- $Z_{load} = 1k\Omega \parallel 80pF$

Under the conditions above, the power dissipation of the Edge818 is as depicted in Table 1.

VCC[V]	VEE[V]	VCC-VEE[V]	$P_{diss}$ [W]	$T_j$ [°C]
12	-3.3	15.3	3.4	77
7.5	-4.6	12.1	2.2	59

**Table 1. Comparison of Edge818 Power Dissipation and Junction Temperature at  $f = 25\text{ MHz}$ ,  $T_a = 25\text{ °C}$ , Airflow = 300 LFPM**

Note that by reducing the power supply levels in the application depicted above, a power savings of 1.2W was realized (and  $T_j$  was reduced by 18 °C).

The power dissipation (and hence  $T_j$ ) of the Edge818 is directly proportional to its operating frequency. This is illustrated in Figures 6 and 7.

Edge 818AHF Power Dissipation vs. Frequency

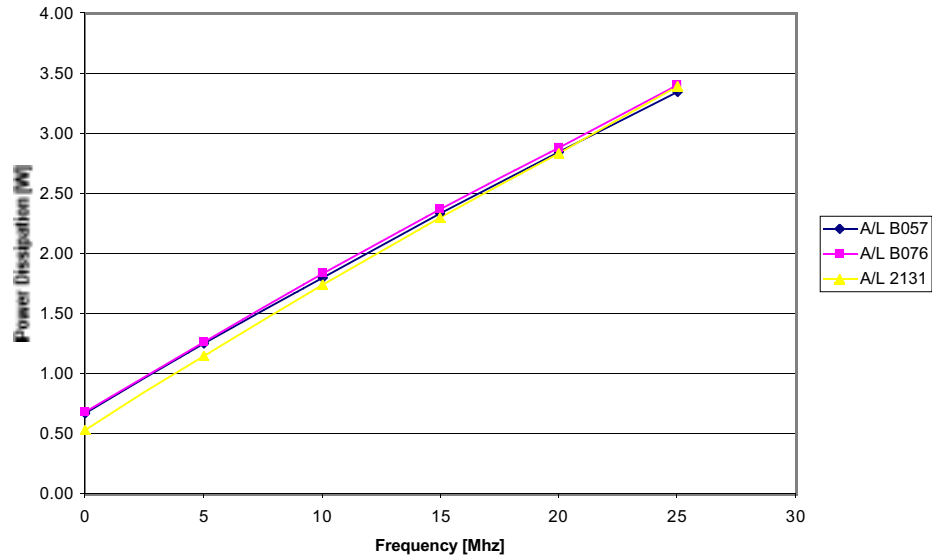

Figure 6. Edge818 Power Dissipation vs. Operating Frequency  
 (VCC = 12V, VEE = -3.3V, VH = 3.3V, VL = 0V, Zload = 1KΩ||80pF, Ta = 25 °C,  
 Airflow = 300 LFPM, All 8 Driver Channels Toggled)

Edge 818 AHF Junction Temperature vs. Operating Frequency

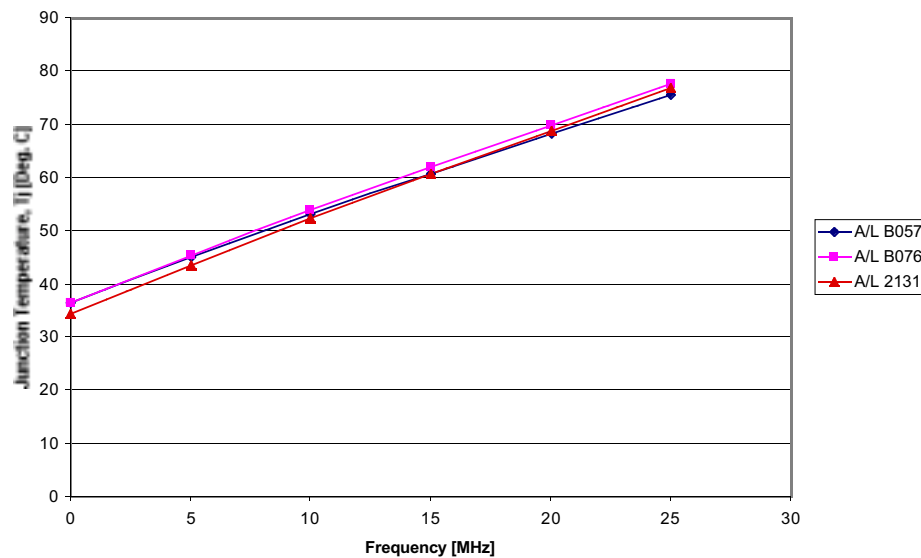
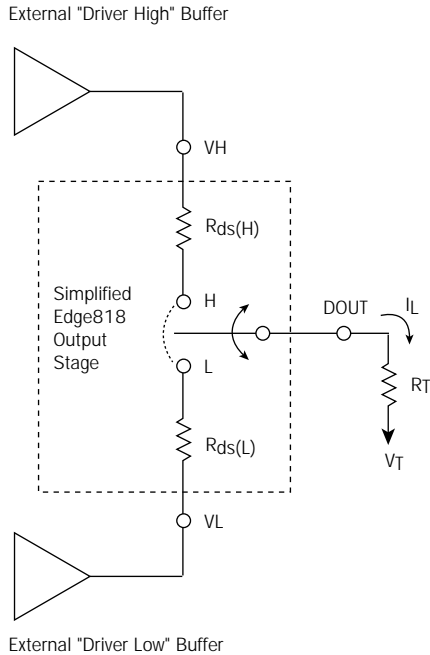

Figure 7. Edge818 Junction Temperature vs. Operating Frequency  
 (VCC = 12V, VEE = -3.3V, VH = 3.3V, VL = 0V, Zload = 1KΩ||80pF, Ta = 25 °C,  
 Airflow = 300 LFPM, All 8 Driver Channels Toggled)



#### Driving a Resistive Load

In addition to the VCC and VEE power supply levels, the “driver high” (VH) and “driver low” (VL) levels used in an application also have an effect on the total power dissipation of the device illustrated using Figure 8.



**Figure 8. Simplified Functional Schematic of Edge818 Output Stage and External Buffers**

The CMOS switches of the Edge818’s output stage have on-resistance values (depicted by  $R_{ds(H)}$  and  $R_{ds(L)}$  in Figure 8) that vary as a function of  $V_H$  and  $V_L$  voltage levels. The amount of current required by the load impedance,  $R_T$ , is also a function of the  $V_H$  and  $V_L$  voltage levels as follows:

Switch in Figure 8 is in position “H”:

$$I_{L(H)} = \frac{V_H - V_T}{R_{ds(H)} + R_T}$$

Switch in Figure 7 is in position “L”:

$$I_{L(L)} = \frac{V_L - V_T}{R_{ds(L)} + R_T}$$

Therefore, the per-channel power dissipation due to the Edge818 driving and resistive load is:

$$P = [I_{L(H)} \times R_{ds(H)} \times D + I_{L(L)} \times R_{ds(L)} \times (1-D)]$$

where

- $P$  = The total power dissipated by the Edge818 as a result of the resistive load,  $R_L$  [W]
- $I_{L(H)}$  = The amount of current required by  $R_L$  during a logic “high” state [A]
- $R_{ds(H)}$  = The output impedance of the Edge818 driver when driving a logic “high” state [ $\Omega$ ]
- $D$  = The normalized amount of time that logic “high” is driven (Duty Cycle)
- $I_{L(L)}$  = The amount of current required by  $R_L$  during a logic “low” state [A]
- $R_{ds(L)}$  = The output impedance of the Edge818 driver when driving a logic “low” state [ $\Omega$ ]

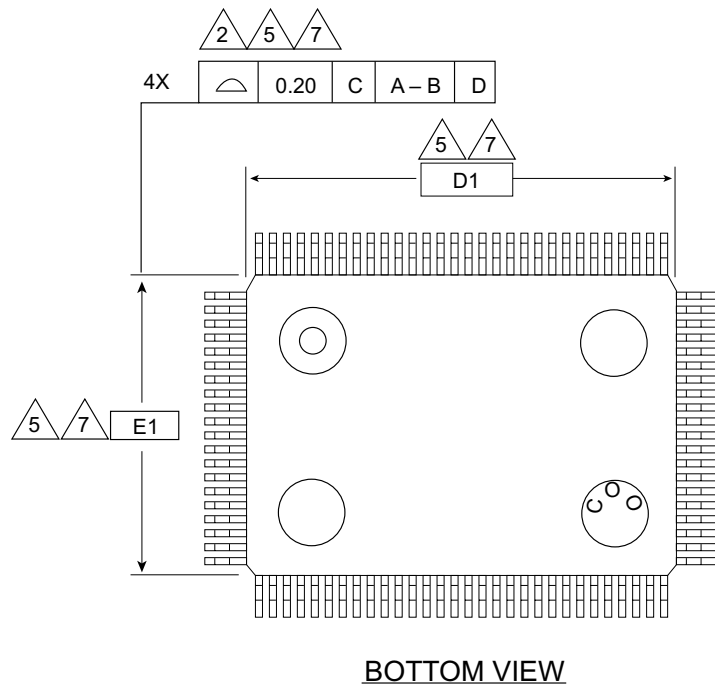
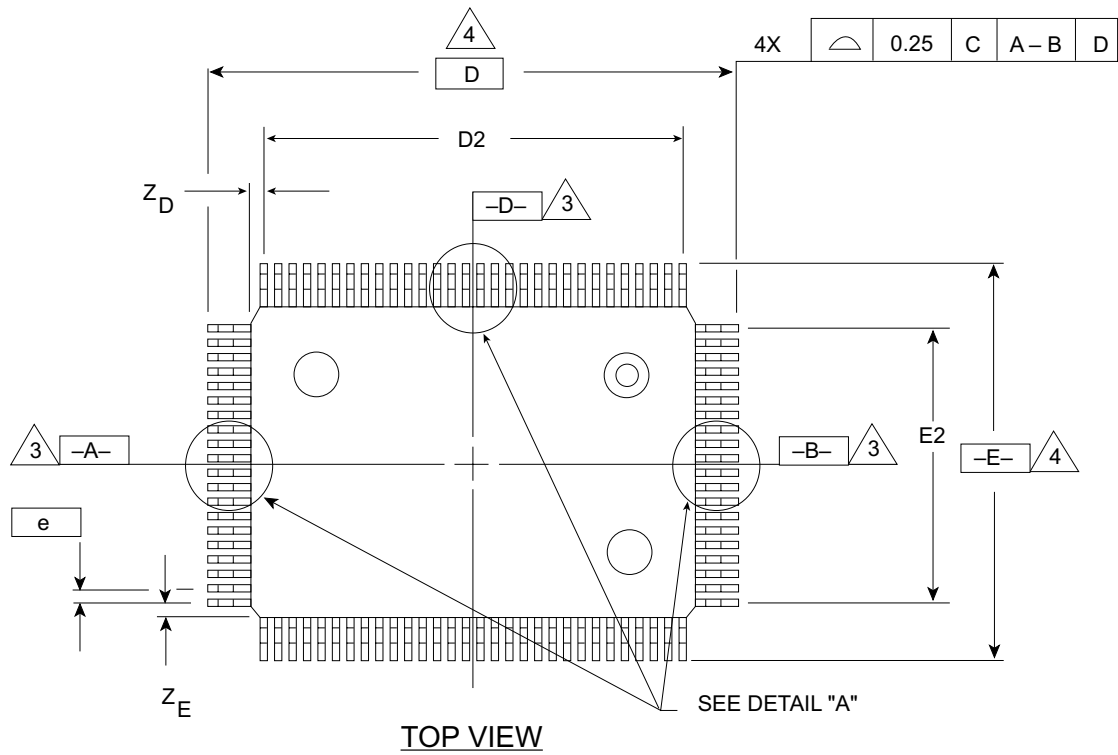
**100-Pin MQFP  
14 mm x 20 mm**

TEST AND MEASUREMENT PRODUCTS

Package Information (continued)

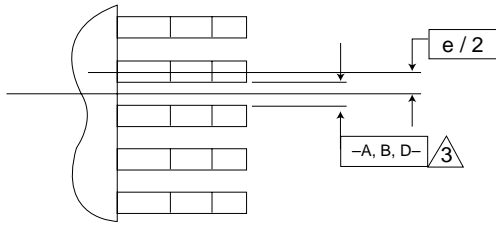

DETAIL "A"

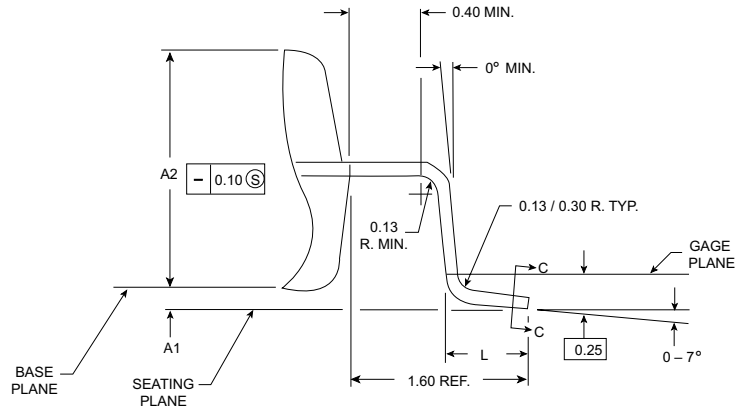

DETAIL "B"

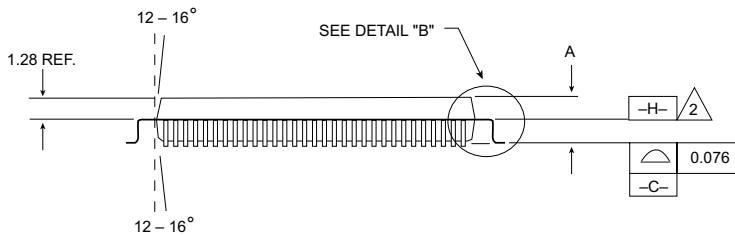

SECTION C-C

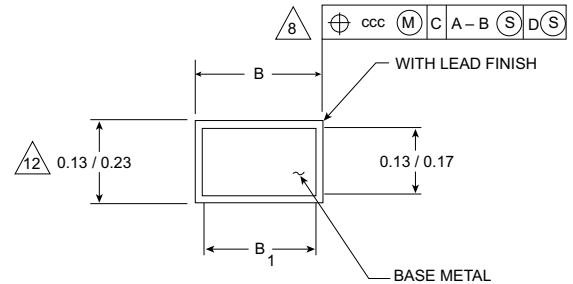

Variations  
(all dimensions in millimeters)

Symbol	Min	Nom	Max	Note	Comments
A		3.04	3.40		Height above PCB
A1	0.25	0.33			Gap above PCB
A2	2.57	2.71	2.87		Body Thickness
D	23.20 BSC			4	
D1	20.00 BSC			5	Body Dimension
D2	18.85 REF				
ZD	0.58 REF				
E	17.20			4	
E1	14.00 BSC			5	Body Dimension
E2	12.35 REF				
ZE	0.83 REF				
L	0.73	0.88	1.03		
N	100			6	Pin Count
e		0.65 BSC			Lead Pitch
B	0.22		0.38	8	Pad Dimension
B1	0.22	0.30	0.33		Pad Dimension
ccc		0.13			
ND	30				Side Pin Count
NE	20				Side Pin Count

Notes:

- All dimensions and tolerances conform to ANSI Y14.5-1982.
- Datum plane -H- located at mold parting line and coincident with lead, where lead exits plastic body at bottom of parting line.
- Datums A-B and -D- to be determined where centerline between leads exits plastic body at datum plane -H-.
- To be determined at seating plane -C-.
- Dimensions D1 and E1 do not include mold protrusion. Allowable mold protrusion is 0.254 mm per side. Dimensions D1 and E1 do include mold mismatch and are determined at datum plane -H-.
- "N" is the total # of terminals.
- Package top dimensions are smaller than bottom dimensions and top of package will not overhang bottom of package.
- Dimension B does not include dambar protrusion. Allowable dambar protrusion shall be 0.08 mm total in excess of the dimension at maximum material condition. Dambar cannot be located on the lowerradius or the foot.
- All dimensions are in millimeters.
- Maximum allowable die thickness to be assembled in this package family is 0.635 millimeters.
- This drawing conforms to JEDEC registered outlines MS-108 and MS-022.
- These dimensions apply to the flat section of the lead between 0.10 mm and 0.25 mm from the lead tip.

**TEST AND MEASUREMENT PRODUCTS**
**Recommended Operating Conditions**

Parameter	Symbol	Min	Typ	Max	Units
Total Analog Supply	VCC - VEE	12.0		18.0	V
Ambient Operating Temperature	TA			+70	°C
Junction Temperature	TJ			+125	°C
Thermal Resistance of Package (Junction to Still Air)	$\theta_{JA}$		32.2		°C/W
Thermal Resistance of Package (Junction to Case)	$\theta_{JC}$		12.4		°C/W

**Absolute Maximum Ratings**

Parameter	Symbol	Min	Max	Units
Total Power Supply	VCC - VEE	-0.5	19.0	V
Digital Input Voltages	DATA, EN*	VEE - .5	VCC + .5	V
Analog Input Voltages	VH, VL, CVA, CVB, VINP, VBB	VEE - .5	VCC + .5	V
Analog Output Voltages	DOUT, COMP HIGH, COMP LOW	VEE - .5	VCC + .5	V
Ambient Operating Temperature	TA	-50	+125	°C
Storage Temperature	TS	-65	+150	°C
Junction Temperature	TJ		+150	°C
Soldering Temperature (5 seconds, .25" from the pin)	TSOL		+260	°C

Stresses above those listed under "Absolute Maximum Ratings" may cause permanent damage to the device. This is a stress rating only, and functional operation of the device at these, or any other conditions beyond those listed, is not implied. Exposure to absolute maximum conditions for extended periods may affect device reliability.

**TEST AND MEASUREMENT PRODUCTS**
**DC Characteristics**

Parameter	Symbol	Min	Typ	Max	Units
<b>Driver</b>					
High Voltage	VH	VEE		VCC	V
Low Voltage	VL	VEE		VCC	V
Output Swing	VH – VL	-18		18	V
HiZ Leakage Current	Ileak	-2.0	0	+2.0	nA
Output Impedance	Rout	9.0	12	15	$\Omega$
DC Output Current (Note 1)	Iout DC	-125		+125	mA
AC Output Current (Note 2)	Iout AC	-400		+400	mA
<b>Receiver</b>					
Input Voltage Range	VINP	VEE		VCC	V
Threshold Voltage Range	CVA, CVB	VEE + 3.0		VCC – 3.0	V
Offset Voltage (Note 3)	Vos	-200		+100	mV
Input Bias Current	Ibias	-10	0	+10.0	nA
Output Voltage Range	COMP HIGH COMP LOW	-2.0 -2.0		+5.0 +5.0	V V
QA, QB Output Impedance	Rout	30	40	50	$\Omega$
DC Output Current Capability		-50		50	mA
<b>Digital Inputs</b>					
Input High Voltage	EN*, DATA - VBB	1.0			V
Input Low Voltage	VBB - EN*, DATA	1.0			V
Input Current	Iin	-100	0	+100	nA
<b>Power Supplies</b>					
Positive Supply Current (Note 4)	ICC	36	57	78	mA
Negative Supply Current (Note 4)	IEE	36	57	78	mA

Test conditions (unless otherwise specified): "Recommended Operating Conditions".

Note 1: DC output current is specified per individual driver.

Note 2: Surge current capability for durations of < 2 seconds.

Note 3: Offset voltage is tested at CVA, CVB = 1.5V.

Note 4: Power supply current tested with VCC = +15V, VEE = -3V.

## TEST AND MEASUREMENT PRODUCTS

## AC Characteristics

Parameter	Symbol	Min	Typ	Max	Units
<b>Driver</b>					
DATA to DOUT	Tpd	9.5	14.5	19.5	ns
EN* to DOUT (Active to HiZ) (Note 1)	Tpd	10	20	30	ns
EN* to DOUT (HiZ to Active)	Tpd	11	16	21	ns
Rise/Fall Times (Note 2)					
1V Swing (20% - 80%)	Tr/Tf		1.5		ns
3V Swing (10% - 90%)	Tr/Tf		1.9		ns
5V Swing (10% - 90%)	Tr/Tf		2.0		ns
10V Swing (10% - 90%)	Tr/Tf		2.5		ns
15V Swing (10% - 90%)	Tr/Tf		3.2		ns
Maximum Operating Frequency (Note 3)	Fmax	50			MHz
Minimum Pulse Width			8	11	ns
<b>Receiver</b>					
Comparator (Note 4)					
Tpd+	Tpd	11.5	17.5	19.5	ns
Tpd-		14.5	20.5	23.5	ns
Maximum Operating Frequency (Note 3)	Fmax	50			MHz
Minimum Pulse Width			10	15	ns

Test conditions (unless otherwise specified): "Recommended Operating Conditions".

*Note 1:* Load = 10 mA and measured when a 1V change at the output is detected. (VH = 3V, VL = 0V, VFLOAT = 1.5V, tested at 1V and 2V.)

*Note 2:* Into 18 cm of 50  $\Omega$  transmission line terminate with 1 K $\Omega$ , with proper series termination resistor. Guaranteed by characterization. This parameter is not tested in production.

*Note 3:* This parameter is production tested at 40 MHz.

*Note 4:* Tested under no-load conditions.

**TEST AND MEASUREMENT PRODUCTS****Ordering Information**

Model Number	Package
E818AHF	100 Lead MQFP 14 mm x 20 mm Body Size w/Internal Heat Spreader
EVM818AHF	Edge818 Evaluation Board

**Contact Information**

Semtech Corporation  
Test and Measurement Division  
10021 Willow Creek Rd., San Diego, CA 92131  
Phone: (858)695-1808 FAX (858)695-2633