

AN8001FHK

Gradation voltage generation IC for liquid crystal display

■ Overview

The AN8001FHK is a gradation voltage generation IC for liquid crystal displays and designed for 64-gradation LCDs. It is incorporating an 1.23 V reference voltage circuit, 10 gradation output buffer amplifier circuits, and a COM amplifier circuit.

■ Features

- Incorporating a high precision reference voltage source : 1.23 V (typ.)
- Wide dynamic range of buffer amplifiers and it is possible to provide an output from $V_{CC} - 0.2$ V (the highest stage) to GND + 0.2 V (the lowest stage).
- Large COM-amplifier drive current : ± 100 mA (max.)

■ Applications

- Gradation power supply source for LCDs

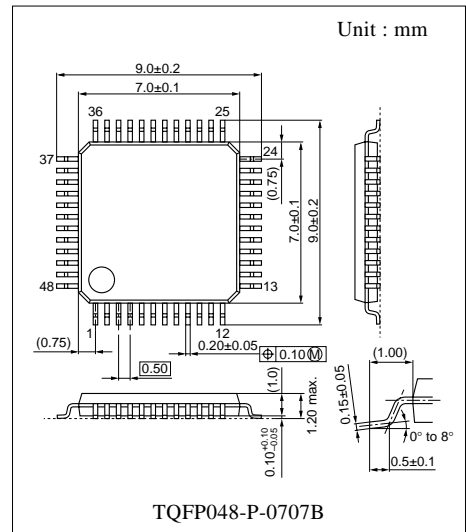

■ Block Diagram

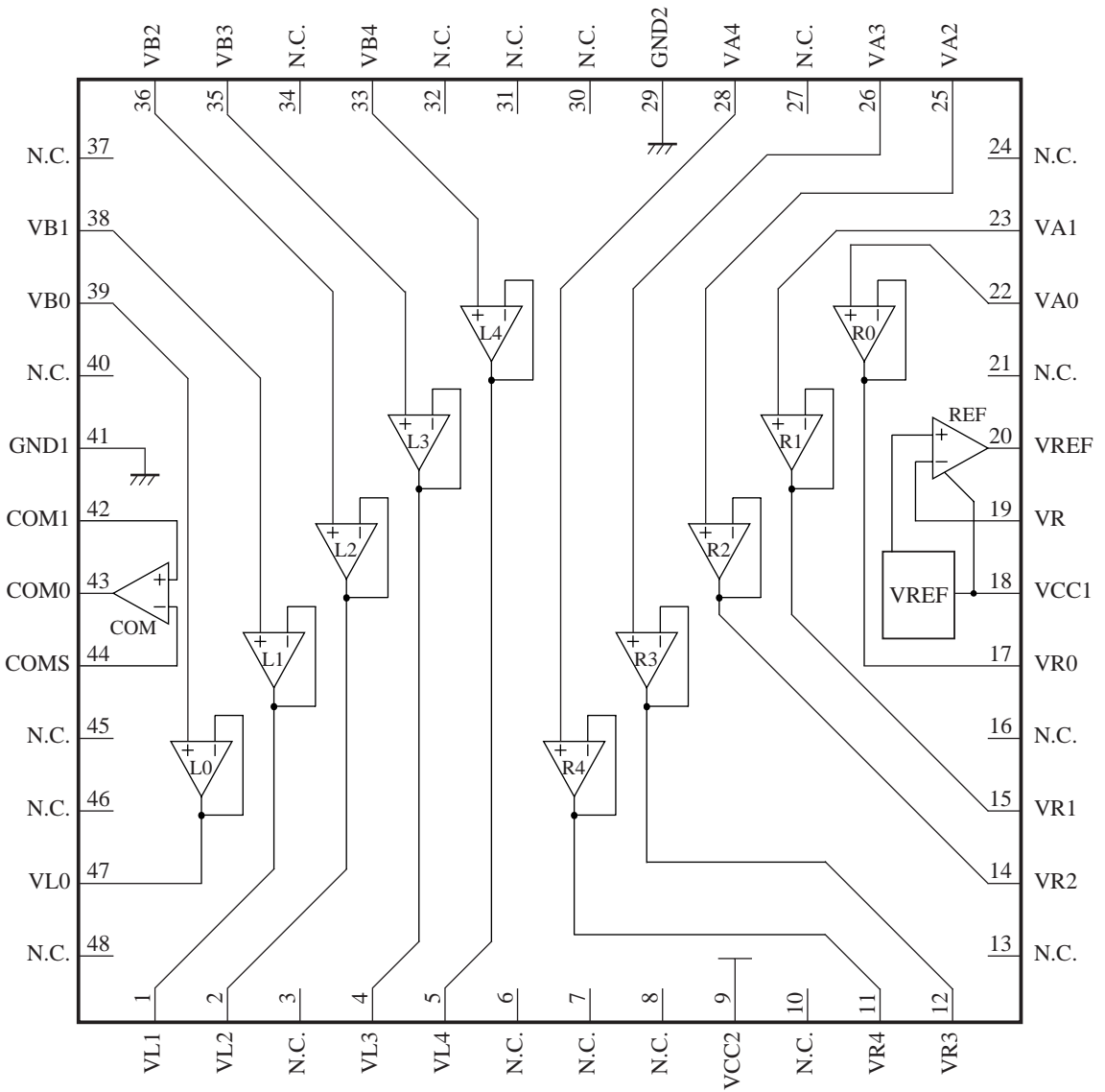

Top View

■ Absolute Maximum Ratings

Parameter	Symbol	Rating	Unit
Supply voltage	V_{CC}	14.2	V
Supply current	I_{CC}	—	mA
REF amplifier output source current	$I_{Osource}$	-5	mA
R0 amplifier output source current	I_{O-R0}	-15	mA
R0 amplifier output sink current	I_{O+R0}	0.1	mA
R1 amplifier output source current	I_{O-R1}	-15	mA
R1 amplifier output sink current	I_{O+R1}	0.1	mA
R/2/3/4, L2/3/4 amplifier output source current	$I_{O-R2-L2}$	-15	mA
R/2/3/4, L2/3/4 amplifier output sink current	$I_{O+R2-L2}$	15	mA
L1 amplifier output source current	I_{O-L1}	-0.05	mA
L1 amplifier output sink current	I_{O+L1}	15	mA
L0 amplifier output source current	I_{O-L0}	-0.05	mA
L0 amplifier output sink current	I_{O+L0}	15	mA
COM amplifier output source current	I_{O-COM}	-100	mA
COM amplifier output sink current	I_{O+COM}	100	mA
Power dissipation	P_D	400* ² 220* ³	mW
Operating ambient temperature* ¹	T_{opr}	0 to +70	°C
Storage temperature* ¹	T_{stg}	-55 to +150	°C
REF amplifier maximum load capacitance	C_{OREF}	0.47	mF
R0/1/2/3/4, L4/3/2/1/0 amplifier maximum load capacitance	$C_{OR/L}$	0.1	μF
COM amplifier maximum load capacitance	C_{OCOM}	10	μF

Note) Either current or voltage should not be applied from the outside to any terminals not specified.

For the circuit current, (+) is current flowing into the IC and (-) is current flowing out of the IC.

Set the input voltage of each amplifier within the range of the output voltage.

*1 : All items are at $T_a = 25^\circ\text{C}$, except for the operating ambient temperature and storage temperature parameters.

*2 : $T_a = 25^\circ\text{C}$

*3 : $T_a = 70^\circ\text{C}$

■ Recommended Operating Range

Parameter	Symbol	Range	Unit
Supply voltage	V_{CC}	7 to 14	V

■ Electrical Characteristics at $T_a = 25^\circ\text{C}$

Parameter	Symbol	Conditions	Min	Typ	Max	Unit
All device						
Circuit current	I_{CC}		—	3.5	6	mA
Reference voltage	V_{REF}		1.19	1.23	1.27	V
Input bias current	I_B		—	—	500	nA
REF amplifier block						
Operating upper limit voltage 1	V_{H1}	Discharge current : 2 mA Connect 0.1 μF or more for oscillation prevention	V_{CC} - 0.2 V	—	—	V
Operating upper limit voltage 2	V_{H2}	Discharge current : 3 mA Connect 0.1 μF or more for oscillation prevention	V_{CC} - 0.3 V	—	—	V
Operating lower limit voltage	V_L	Connect 0.1 μF or more for oscillation prevention	—	—	V_{REF}	V
R0 amplifier block						
Output upper limit voltage 1	$V_{H,R01}$	Discharge current : 10 mA	V_{CC} - 0.2 V	—	—	V
Output upper limit voltage 2	$V_{H,R02}$	Discharge current : 15 mA	V_{CC} - 0.25V	—	—	V
Output lower limit voltage	$V_{L,R0}$	Sink current : 0.1 mA	—	—	V_{CC} - 3 V	V
Offset voltage	V_{OFFR0}		—	—	10	mV
R1 amplifier block						
Output upper limit voltage	$V_{H,R1}$	Discharge current : 15 mA	V_{CC} - 0.7 V	—	—	V
Output lower limit voltage	$V_{L,R1}$	Sink current : 0.1 mA	—	—	$V_{CC}/2$	V
Offset voltage	V_{OFFR1}		—	—	10	mV
R2/R3/R4/L2/L3/L4 amplifier block						
Output upper limit voltage 1	$V_{H,R2-R4}$	Discharge current : 15 mA	V_{CC} - 1.5 V	—	—	V
Output lower limit voltage 1	$V_{L,R2-R4}$	Sink current : 15 mA	—	—	2	V
Output upper limit voltage 2	$V_{H,L2-L4}$	Discharge current : 15 mA	V_{CC} - 2 V	—	—	V
Output lower limit voltage 2	$V_{L,L2-L4}$	Sink current : 15 mA	—	—	1.5	V
Offset voltage	V_{OFF234}		—	—	10	mV
L1 amplifier block						
Output upper limit voltage	$V_{H,L1}$	Discharge current : 50 μA	$V_{CC}/2$	—	—	V
Output lower limit voltage	$V_{L,L1}$	Sink current : 15 mA	—	—	0.7	V
Offset voltage	V_{OFFL1}		—	—	15	mV

■ Electrical Characteristics at $T_a = 25^\circ\text{C}$

Parameter	Symbol	Conditions	Min	Typ	Max	Unit
L0 amplifier block						
Output upper limit voltage	$V_{H,L0}$	Discharge current : 50 μA	3	—	—	V
Output lower limit voltage	$V_{L,L0}$	Sink current : 15 mA	—	—	0.2	V
Offset voltage	V_{OFFL0}		—	—	15	mV
COM amplifier block						
Output upper limit voltage	$V_{H,COM}$	Discharge current : 100 mA	V_{CC} -2.5 V	—	—	V
Output lower limit voltage	$V_{L,COM}$	Sink current : 100 mA	—	—	2.5	V
Offset voltage	V_{OFFCOM}		—	—	10	mV

• Design reference data

Note) The following characteristics are the reference values for design and not guaranteed values.

Parameter	Symbol	Conditions	Min	Typ	Max	Unit
Recovery time	Ri-Time COM		—	—	2	μS
REF amplifier block Supply voltage rejection ratio	PSRR_{REF}	f = 10 kHz to 500 kHz 200 mV[p-p], 0.1 μF connection	—	—	-40	dB
R0 amplifier block Supply voltage rejection ratio	PSRR_{R0}	f = 10 kHz to 500 kHz 200 mV[p-p], 0.01 μF connection	—	—	-10	dB
R1 amplifier block Supply voltage rejection ratio	PSRR_{R1}	f = 10 kHz to 500 kHz 200 mV[p-p], 0.01 μF connection	—	—	-20	dB
R2/R3R/4 amplifier block Supply voltage rejection ratio	$\text{PSRR}_{\text{R234}}$	f = 10 kHz to 500 kHz 200 mV[p-p], 0.01 μF connection	—	—	-40	dB
R2/R3R/4 amplifier block Supply voltage rejection ratio	$\text{PSRR}_{\text{L234}}$	f = 10 kHz to 500 kHz 200 mV[p-p], 0.01 μF connection	—	—	-40	dB
L1 amplifier block Supply voltage rejection ratio	PSRR_{L1}	f = 10 kHz to 500 kHz 200 mV[p-p], 0.01 μF connection	—	—	-10	dB
L0 amplifier block Supply voltage rejection ratio	PSRR_{L0}	f = 10 kHz to 500 kHz 200 mV[p-p], 0.01 μF connection	—	—	-20	dB
COM amplifier block Supply voltage rejection ratio	PSRR_{COM}	f = 10 kHz to 500 kHz 200 mV[p-p], 0.1 μF connection	—	—	-40	dB

■ Technical Data

• Characteristics curve

Power supply current — temperature characteristics
($I_{CC} - T_a$)

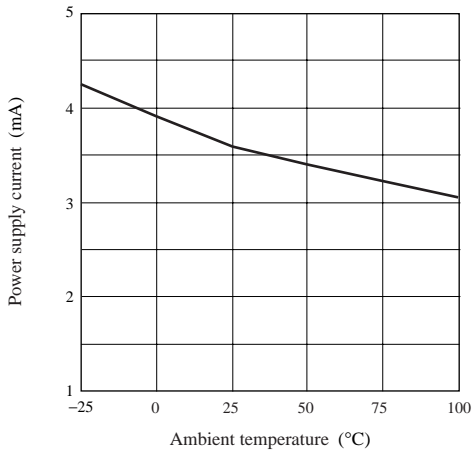

Reference voltage — temperature characteristics
($V_{REF} - T_a$)

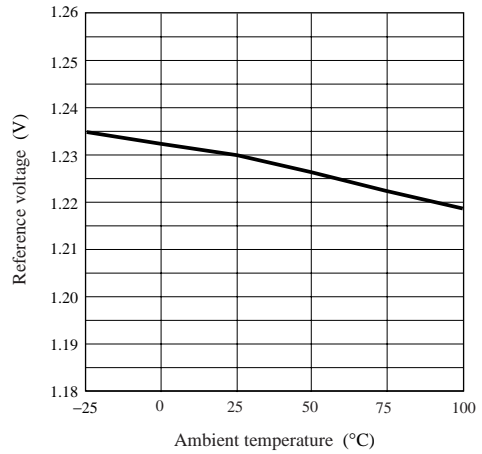

■ Application Example

• System configuration example

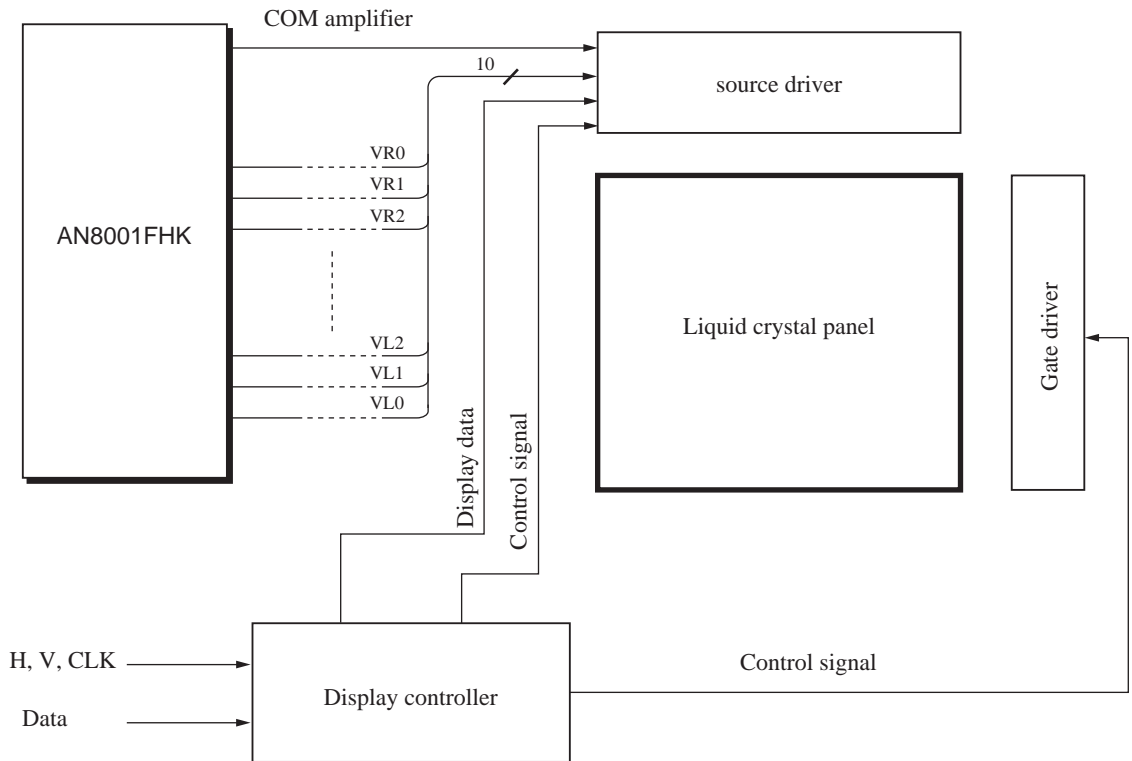

■ Application Example (continued)

- Application circuit example

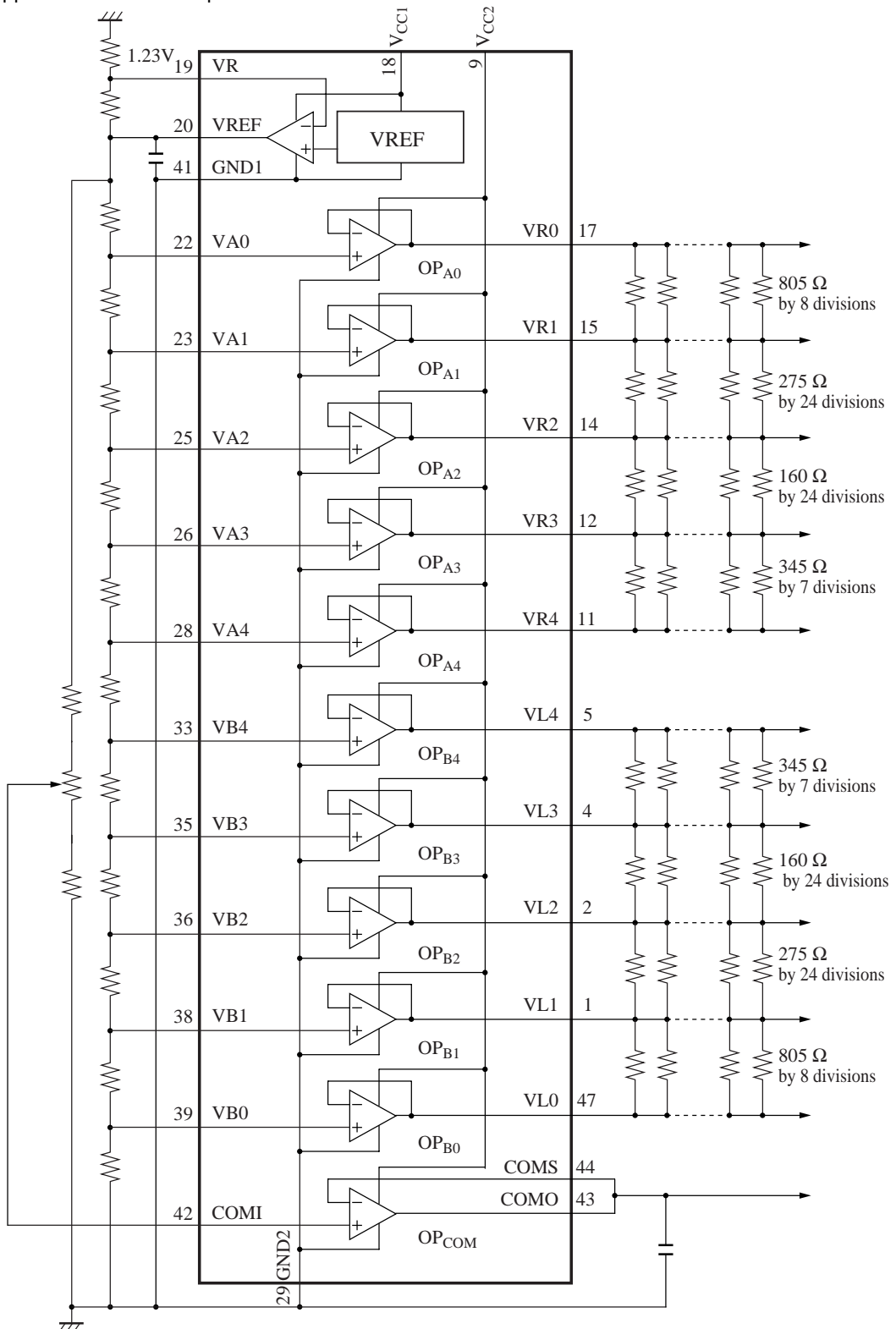

■ Application Example (continued)

<Recommended operating conditions>

Parameter	Symbol	Ratings	Unit	Notes
Supply voltage	V_{CC}	10.5	V	
Load capacitance	C_{LOAD}	0.01	μF	VR0 to VL0
		0.1 to 1	μF	COM0
		0.1	μF	V_{REF}